

**LECTURE NOTES
ON
AUTOMOBILE ENGINEERING AND
HYBRID VEHICLES**



**6TH SEMESTER
DEPT OF MECHANICAL ENGG.
AUM SAI INSTITUTE OF TECHNICAL EDUCATION
NARAYANPUR, BERHAMPUR, GANJAM**

**PREPARED BY:
ER. MALLAPI DEBASHREE GAYATRI REDDY**

AUTOMOBILE ENGINEERING AND HYBRID VEHICLES

Name of the Course: Diploma in MECHANICAL ENGINEERING			
Course code:		Semester	6th
Total Period:	60	Examination	3 hrs
Theory periods:	4 P/W	Internal assessment	20
Maximum marks:	100	End Semester Examination:	80

A. RATIONALE:

Automobiles are the principal mode of transport system. Their manufacture and maintenance gives a major scope for employment. Many entrepreneur pass outs go for servicing of automobiles or trading/manufacturing of auto components. Thus automobile engineering is an important subject to be in the regular curriculum of the mechanical engineering.

B. COURSE OBJECTIVES:

At the end of the course the students will be able to:

- Understand automobile chassis, transmission, breaking and fuel system etc.
- Understand the basics of electric vehicle kinematics.
- Understand the concepts of hybrid electric vehicles.

C. TOPIC WISE DISTRIBUTION OF PERIODS

Sl No.	Topic	Periods
1	Introduction & Transmission System	12
2	Braking system	5
3	Ignition & Suspension System	10
4	Cooling and Lubrication	8
5	Fuel system	10
6	Hybrid and Electric Vehicles	15

C. COURSE CONTENTS

1.0 INTRODUCTION & TRANSMISSION SYSTEM:

- 1.1 Automobiles: Definition, need and classification: Layout of automobile chassis with major components (Line diagram)
- 1.2 Clutch System: Need, Types (Single & Multiple) and Working principle with sketch
- 1.3 Gear Box: Purpose of gear box, Construction and working of a 4 speed gear box
- 1.4 Concept of automatic gear changing mechanisms
- 1.5 Propeller shaft: Constructional features
- 1.6 Differential: Need, Types and Working principle

2.0 BRAKING SYSTEM:

- 2.1 Braking systems in automobiles: Need and types
- 2.2 Mechanical Brake
- 2.3 Hydraulic Brake
- 2.4 Air Brake
- 2.5 Air assisted Hydraulic Brake

3.0 IGNITION & SUSPENSION SYSTEM:

- 3.1 Describe the Battery ignition and Magnet ignition system
- 3.2 Spark plugs: Purpose, construction and specifications
- 3.3 State the common ignition troubles and its remedies
- 3.4 Description of the conventional suspension system for Rear and Front axle
- 3.5 Description of independent suspension system used in cars (coil spring and tension bars)
- 3.6 Constructional features and working of a telescopic shock absorber

4.0 COOLING AND LUBRICATION:

- 4.1 Engine cooling: Need and classification
- 4.2 Describe defects of cooling and their remedial measures
- 4.3 Describe the Function of lubrication
- 4.4 Describe the lubrication System of I.C. engine

5.0 FUEL SYSTEM:

- 5.1 Describe Air fuel ratio
- 5.2 Describe Carburetion process for Petrol Engine
- 5.3 Describe Multipoint fuel injection system for Petrol Engine
- 5.4 Describe the working principle of fuel injection system for multi cylinder Engine
- 5.5 Filter for Diesel engine
- 5.6 Describe the working principle of Fuel feed pump and Fuel Injector for Diesel engine

6.0 ELECTRIC AND HYBRID VEHICLES:

- 6.1 Introduction, Social and Environmental importance of Hybrid and Electric Vehicles
- 6.2 Description of Electric Vehicles, operational advantages, present performance and applications of Electric Vehicles
- 6.3 Battery for Electric Vehicles, Battery types and fuel cells
- 6.4 Hybrid vehicles, Types of Hybrid and Electric Vehicles: Parallel, Series, Parallel and Series configurations;
- 6.5 Drive train
- 6.6 Solar powered vehicles

TRANSMISSION SYSTEM

1. EXPLAIN IN DETAIL ABOUT VEHICLE CONSTRUCTION, CHASSIS, FRAME AND BODY (OR) DRAW THE LAYOUT OF AN AUTOMOBILE AND INDICATE THE VARIOUS COMPONENTS.

An automobile is made up of mainly two units, these are Chassis and Body.

- “Frame” + “Base components” = “Chassis”
- “Chassis” + “Body” = “Vehicle”

Chassis

- A vehicle arrangement without body is called chassis.
- Various components and systems of the chassis are
 - ❖ The power system - Power units are clutch, gearbox transmission, differential, Rear axle shaft, universal joint & propeller shaft etc ...
 - ❖ Running system - Running systems consists brakes, wheels, frame, suspension and steering system
 - ❖ Electrical system - Electrical system consists of starting circuit, charging circuit, ignition circuit lighting and horn circuit.

Body

- The purpose of the body is to provide accommodation to the driver and the passenger and to protect them against adverse conditions

COMPONENTS OF AN AUTOMOBILE

Automobile consists of the Basic structure, the Power plant, the transmission system, the auxiliaries, the controls and the superstructure.

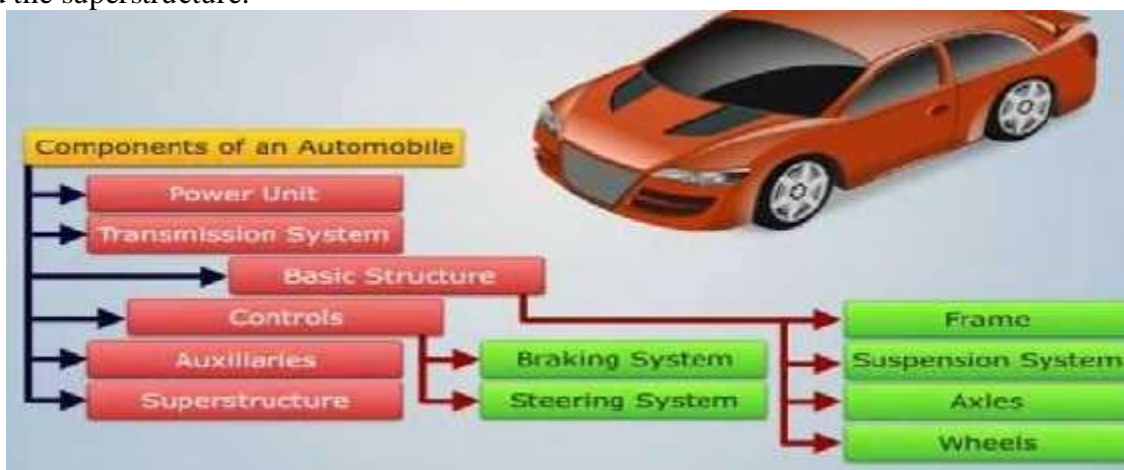

BASIC STRUCTURE:

- This is the unit on which are to be built the remainder of the units required to turn it into a power operated vehicle. It consists of the frame, the suspension systems, axles, wheels and tyres.

THE FOLLOWING MAIN COMPONENTS OF THE CHASSIS ARE

- Frame: it is made up of long two members called side members riveted together with the help of number of cross members.
- Engine or Power plant: It provides the source of power.
- Clutch: It connects and disconnects the power from the engine fly wheel to the transmission system.
- Gear Box- the energy transmitted will In effect change the speed, direction, or torque of the machine where it is installed.
- Universal Joint- The universal joint allows the drive shaft to move up and down, to allow for suspension

travel. Some drive shafts also have slip joint the allows the drive shaft to make minor length changes as the vehicle suspension height changes

- Propeller Shaft- shaft makes any vehicle move by connecting the rear differential to the engine and transmission system. It is a mechanical component shaped like a tube which allows the transmission to the differential.

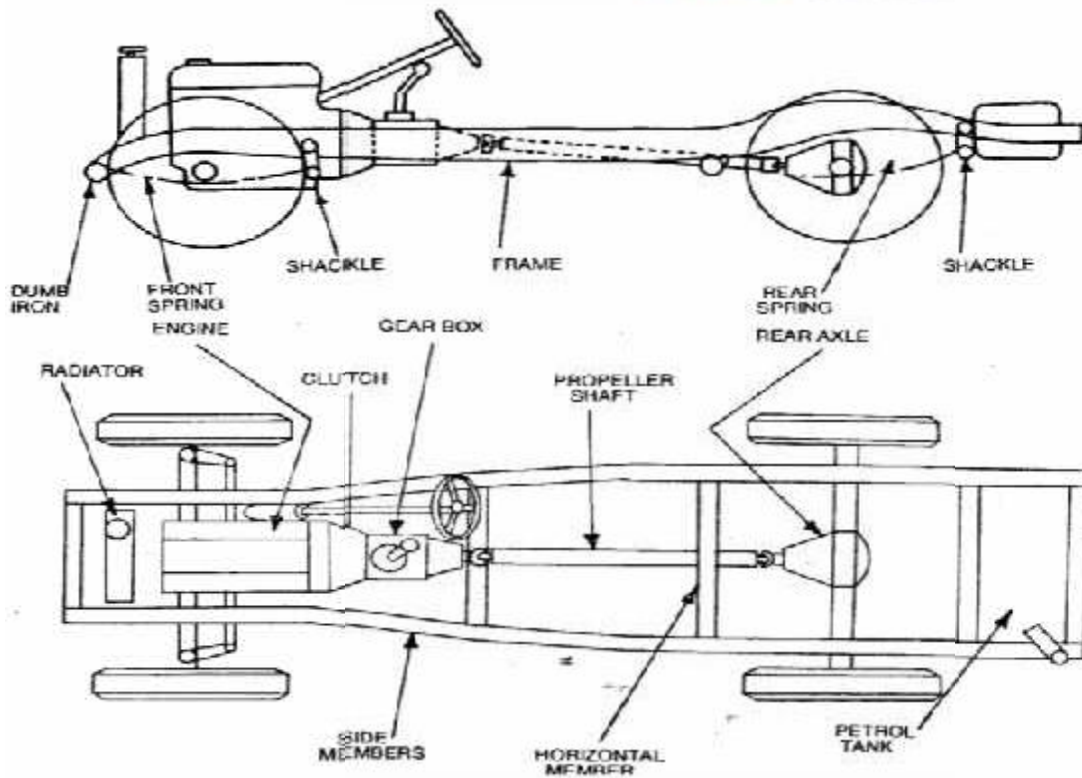
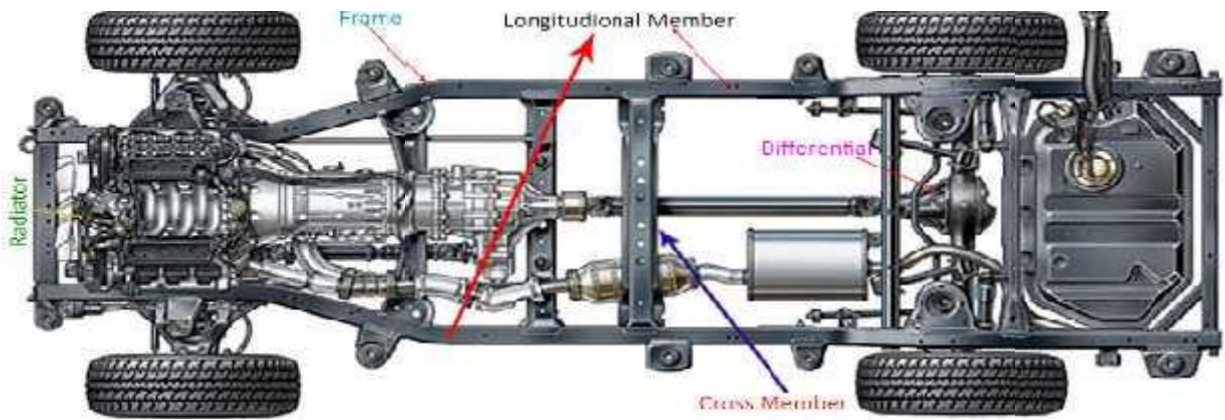

- Differential- It is a device that splits the engine torque two ways, allowing each output to spin at a different speed. The differential is found on all modern cars and trucks, and also in many all-wheel drives

Suspension System

Function of suspension system

- To stable the vehicle from shocks and vibration due to irregular road surface.
- To reduced or prevent the road shocks which are transmitted on the vehicle Frame.
- To regulate stability when vehicle is in motion.
- To maintain proper steering geometry.

Location of suspension system

- Location of suspension is in between axles and chassis.

Axle

There are two types of axles

- Live axle
- Dead axle

Function of live axle

- Live axle is the two half axle. In between them differential is attached, function of live shaft is to transmit the power from engine to wheel.
- It carries the weight of vehicle.

Function of dead axle

- It carries the load of engine.
- When brakes are provided at front wheels then it withstands bending or torsional stresses.
- It is support to the wheels.

Wheels and Tires

Function of wheels or tire

- To support the load of vehicle
- To provide cushion against the shock
- Good road grip when we accelerate or breaking the vehicle.
- To sustain the load of vehicle.
- To create contact with road surface.

Location

- It locate on front or rear axle (depends on drive used in vehicle)

Fuel System

- The fuel tank is fastened to the rear of the frame and is connected to the fuel pump through metal tubes. The exhaust pipe and muffler conducts the poisonous gases from the engine to the rear of the vehicle.

Cooling System

- A radiator is mounted on the chassis which is connected to the engine by rubber hoses to allow cooling water or coolant to circulate between radiator and engine. Fan, water pump and fan belt are other parts of the cooling system.

THE POWER SOURCE / POWER PLANT

- There are various sources of Power for vehicle, the selection of power plant is depends on the type of vehicle used. In many passenger vehicles, the internal combustion engine (IC Engine) is used.
- Now days the technology has been develop continuously, we can observed that some passenger cars also able to drive by electric motor and batteries. In this year porches is working on Porsche 618 two wheeler model which is electric drive; Porsche claims that it is able to achieve 160Ps power. Anyway it's not good point to discuss yet.
- Engineers worked on Hybrid vehicle, Hybrid vehicle is the fusion of IC engine and electric motor. The vehicle is able to use both IC engine as well as the electric motor.

There are two basic types of Power-plant of vehicle as follows:

- ❖ IC engine
- ❖ Electric motor
- ❖ Hybrid (fusion of IC engine & Electric motor)

Function of Power-plant / power source

- To generate a power required for propelling the vehicle.
- To create and transmit the power to transmission system.
- It serves as a prime component in automobile transmission system.

Location of Power-plant / Power source

- In two wheeler bike it is located below the fuel tank.
- In four wheeler it is located near the side doors.

THE TRANSMISSION SYSTEM

- It consists of a clutch, a gear box, a transfer case, a propeller shaft, universal joints, final drive, and differential gear.
- The transmission system consists of Clutch, Gear-Box, Propeller shaft and differential.
- Clutch is used for enable the drives to transmit the power whenever required, it also has purpose to disconnect the drive from engine from road wheels. Generally we used Multi plate clutch and single plate clutch in vehicle.
- Gear-Box is able to give various ratio of speed to achieve required torque to achieve speed of vehicle. It also worked as torque converter for vehicle; Gear box is able to transmit tractive effort to the wheel to propel the vehicle. Generally we used Manual type, semi-automatic (DCT), Automatic transmission (hydraulic & pneumatic fusion kit) and CVT.
- Differential provides permanent reduction in speed, it is necessary because speed of engine has to be maintained at optimum level at all the times. It also adjusts the rotational speed of wheels at turning the vehicle.
- Universal joints are able to provide relative motion between engine and driving wheel due to flexing bad springs.
- Following figure shown the function of CVT.

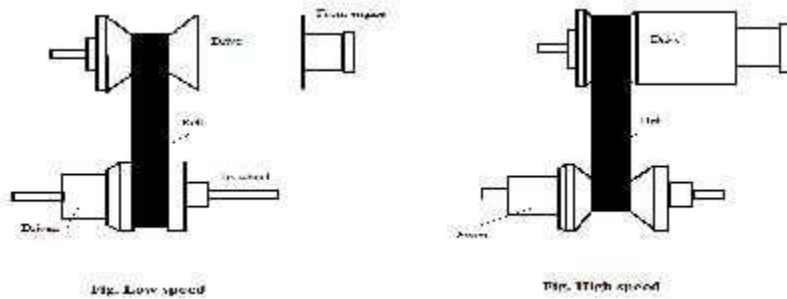

Function of Transmission system:

- To disconnect engine from road wheels whenever required.
- Connect the engine to driving wheels without shock.
- Vary the torque ratio.
- Turn the drive through right angle.
- Work as torque converter.

THE AUXILIARIES

- The principles one out of this is that, it is common to almost all types of vehicles i.e., the electrical equipment. This can be subdivided in 4 sub-systems.
- Supply system (battery and generator)
- Battery and magneto ignition system.
- The starter
- Ancillary Devices eg. Driving light, Headlamp, Side light, Tail lights, horn, and direction indicator.

THE CONTROLS

It is divided in two types;

Brake System

- The complete brake system is incorporated in the chassis. The brake pedal controls a master cylinder which is connected to brakes on each wheel by oil lines.

Steering System

- Some parts of the steering system (steering gear) are bolted to the frame and some (steering column) connected to the body.

THE SUPER-STRUCTURE

- In those cases, where frame-less construction is not adopted, there must be separate super-structure i.e. the body attached to the frame while in case of frame-less construction; the body performance functions of both.
- The shape of body depends upon the ultimate use for which the vehicle is meant. The shapes like SUV, Sedan, Hatchback, Wagon, sport, mini vehicle, passenger, goods carrier etc.



1. Car

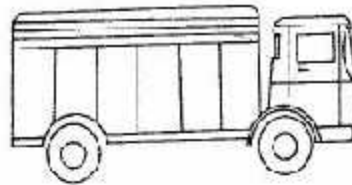

2. Truck Punjab body or Straight truck

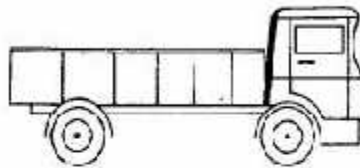

3. Truck half body



4. Truck platform type

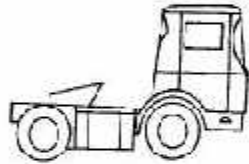

5. Tractor

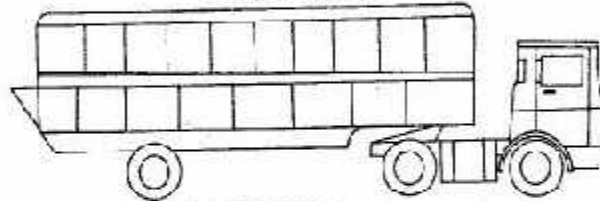

6. Tractor with articulated trailer



7. Tanker

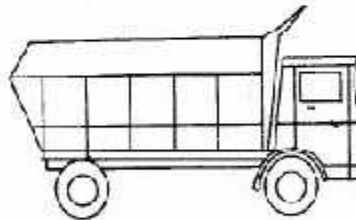

8. Dumper truck

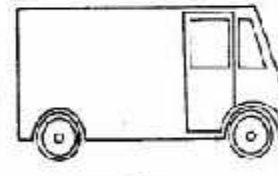

9. Delivery Van

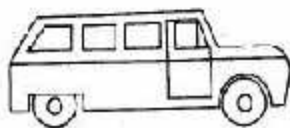

10. Station wagon

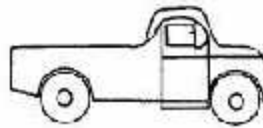

11. Pick-up



12. Jeep

The shape of the body depends upon the ultimate use for which the vehicle is meant.

1. Car Body Styles

(i) Closed Cars

- Saloon : Has two or four door, a single compartment with two rows of seats, one at the front and the other at the rear. There is a separate luggage space at the rear or at the front.
- Hatchback: A saloon with a door at the back is called hatchback.

➤ Coupe: In this type there is only one row of seats for two persons. Only two doors are provided. An ordinary 'saloon' with roof-line at decreased height is also called coupe sometimes. The term G.T. (grand touring) added to 'coupe' means a car of performance which is better than the average.

➤ Limousine: Driving compartment is separated from the rear compartment by a sliding glass division.

(ii) Open cars

➤ Sports: Has two doors or less, is provided with a collapsible hood, a fold flat windscreen and removable side-screens.

➤ Convertible: The roof is of soft folding type and windows of special wind-up design. With these provisions the car may be either open or enclosed.

(iii) Special styles

➤ Estate Car : A saloon car with the passenger roof extended right up to the rear end. Rear door for loading with rear seats usually collapsible.

➤ Station Wagon: Wood-panelled body in earlier days but now only with a resembling look over the steel structure. Rear doors and seats for four or five persons.

2. Transport Vehicles

➤ Van : These are light transport vehicles. There are seats at the front and the luggage space at the rear. The side doors are usually of sliding type. The rear door is used for loading or unloading.

➤ Truck: These are heavy goods commercial vehicles with all the axles attached to a single frame. Generally twin wheels are fitted on the non-steered axles. Depending upon the load capacity, there are two or more axles.

➤ Articulated vehicle: This is also heavy goods vehicle consisting of a tractor and a semi-trailer. The tractor provides the motive power while the trailer carries the goods. The two units are connected by means of a fifth-wheel coupling. This type of vehicle has smaller turning circle than the rigid truck. Moreover, the trailer being detachable, the tractor can directly move off after reaching with some other trailer without having to wait for unloading and re-loading. However, in this there is less traction available. Moreover, steering is more difficult as the trailer wheels do not follow the same path as the traction wheels.

➤ Bus: These are used for carrying large number of people over short distances often in dense traffic. Not much space for luggage is provided, but there is adequate visibility for the passengers to know where they have to get down. Usually, there are two doors, the one at the rear for mounting and one at the front for getting down. Sometimes, the buses have two floors. Such buses are called double decker buses.

➤ Coach: these are used for transporting passengers over long distances and are, therefore, provided with luxurious interior with comfortable adjustable seats and amenities like video.

2. EXPLAIN THE CONSTRUCTION OF VARIOUS FRAMES USED IN AUTOMOBILES WITH NEAT SKETCH. (OR)

COMPARE THE MERITS AND DEMERITS OF A FRAMELESS CONSTRUCTION WITH THOSE OF THE CONVENTIONAL FRAMED CONSTRUCTION. (OR)

EXPLAIN THE FOLLOWING TERMS: (I) LOAD DISTRIBUTION IN FRAMES (II) FRAME TYPES WITH SKETCH (III) FRAME MATERIALS (IV) FRAME TESTING. (OR)

EXPLAIN WITH NEAT SKETCHES THE VARIOUS TYPES OF CHASSIS & DISCUSS THEIR ADVANTAGES AND DISADVANTAGES.

➤ Chassis is a French term and was initially used to denote the frame parts or Basic Structure of the vehicle. It is the back bone of the vehicle.

➤ A vehicle without body is called Chassis.

➤ The components of the vehicle like Power plant, Transmission System, Axles, Wheels and Tyres, Suspension, Controlling Systems like Braking, Steering etc., and also electrical system parts are mounted on

the Chassis frame. It is the main mounting for all the components including the body. So it is also called as Carrying Unit.

Function of frame

- To carry load of the passengers or goods carried in the body.
- To support the load of the body, engine, gear box etc.,
- To withstand the forces caused due to the sudden braking or acceleration
- To withstand the stresses caused due to the bad road condition.
- To withstand centrifugal force while cornering

Various loads acting on the frame

- The body should be light.
- It should have minimum number of components.
- It should provide sufficient space for passengers and luggage.
- It should withstand vibrations while in motion.
- It should offer minimum resistance to air.
- It should be cheap and easy in manufacturing.
- It should be attractive in shape and colour.
- It should have uniformly distributed load.
- It should have long fatigue life
- It should provide good vision and ventilation.

TYPES OF CHASSIS FRAMES:

There are three types of frames

- Conventional frame
- Integral frame
- Semi-integral frame

1. The Conventional frame

- Pressed steel frame to which all the mechanical units are attached and on which the body is superimposed. (It also called as “Separate body and chassis type”, “Orthodox type”)
- The body and chassis will be as separate unit.
- Bolts are used to join the body and chassis together.
- The separate part of body will be placed over the top of the chassis.
- A rubber block will be placed in between these two parts to avoid the vibration.
- The conventional type building involves in building up of a ladder type frame with two long side members interconnected by cross members at intervals.
- The units like engine, gear box, radiator, axles, steering wheel, fuel tank are mounted on the frame.
- The whole body and passenger load is transmitted to the chassis by means of spring.

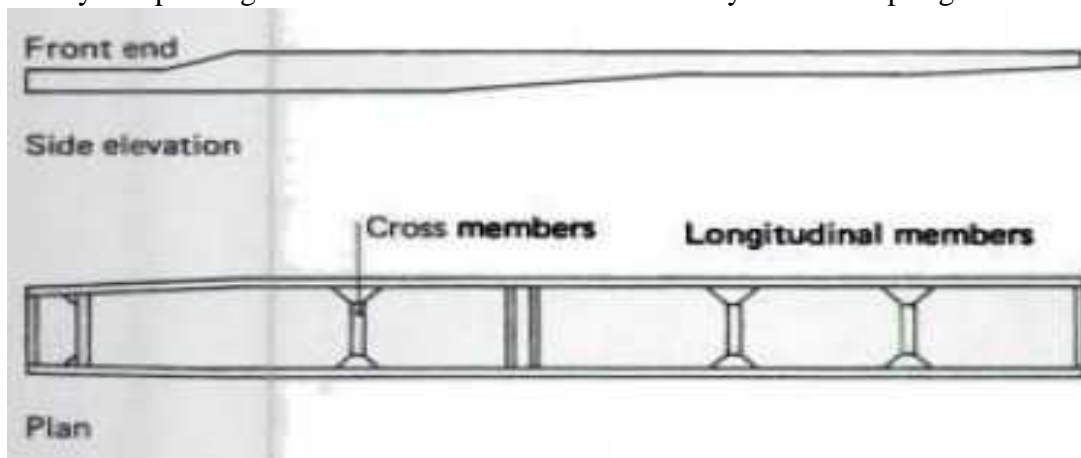

- Chassis should be built strong so that it can withstand the weight of the body
- The basic under body structure is fabricated only thin mild steel cold rolled channel sections
- It is fully galvanized for corrosion protection
- It is provided with cross members and out riggers at specified intervals.
- The pillar and roof shocks are made of sheet steel.
- Pillars are bolted to the sole bar of the under structure.
- The roof sticks are connected to the pillars by stiff pressed steel corner brackets and joined by solid rivets.
- All the inner panels and wheel arch truss panels are sheet steel and solid steel riveted to the pillars.
- All the outer panels and roof panels are pop riveted.

The frame sections are generally, used

- Channel Section - Good resistance to bending
- Tabular Section - Good resistance to Torsion
- Box Section - Good resistance to both bending and Torsion
- I- section
- T-section
- Z-section
- L-section
- Top hat section
- Box with rebate
- I- section with flange
- H- section for pillar
- Y- section
- Π - Section



I section



L section



Channel section

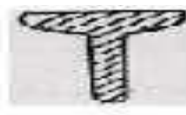

T section



Z section



Top hat section



Box with rebate



I section with flange



Box [rectangle]



H section for pillar



Y section



π section

Advantage

- This is used in heavy vehicle.
- This is of simple construction.
- The change of designing and the alteration of frame length is easy.
- Servicing is easy in case of any damage.
- There is no need for more expenditure for preventing corrosion.

Disadvantage

- The weight of the frame is more; due to this the vehicle speed is decreased. More fuel is also required.
- Since the floor height is more, the centre of gravity from the ground will also be more. Due to this, the stability will be decreased.

2. Integral or frameless construction (Monocoque)

- The body structure combines the functions of body and frame. The frameless construction is possible only in the case of closed car, since the roof, screen pillars and rear panel are essentially load-taking parts of the structure.
- Monocoque, meaning 'single shell' in French, is a construction technique that utilizes the external skin to support some or most of the load. The technique may also be called structural skin or stressed skin.
- The semi-monocoque is a hybrid of a mutually reinforcing tensile shell and compressive structure.
- Unitary body / unit body - uses a system of box sections, bulkheads and tubes to provide most of the strength of the vehicle, to which the stressed skin adds relatively little strength or stiffness.
- In integral bus construction, a base structure is formed with 4 long Side members, cross members, outriggers and wheel arch supports.
- Units like engine, gear box, axles etc are mounted on the flexible Under structure, which is fabricated by welding.
- These under structures are painted with suitable colors to prevent corrosion .
- The body pillars which are ring frames are attached to the two extreme Side members called sole bars by bolting.
- The paneling is done as per specifications to give good integral Structure.
- The under and body structure act as a single structure to carry the Load. Thus for a given load the integral structure will withstand more stress which indicates that every member of the structure is sharing the load.

The frameless construction has the following advantages over the conventional framed construction

- Reduced weight and saving in fuel consumption.
- Low manufacturing cost.
- During collision, the body absorbs the shock due to impact and providing safety to the passengers.
- Lower body position and increased stability of the automobile.
- These advantages are accompanied by the following disadvantages also:
- Reduction of strength and durability.
- Economical only if frameless construction is adopted in mass production.
- Increased cost of repairs in case of damage to body during accidents.
- Topless cars are difficult to design with the frameless construction.

Design of Integral Bus

Chassis under structure

- Unit weights like engine, gear box, radiator, steering box, batteries and fuel tank acting as point loads at the mounting points.
- Weight of under structure considered as uniformly distributed load.
- Considering the vertical and lateral bending, moment is calculated and a section required to carry the weights is decided allowing for a reserve factor depending on the road conditions.

Chassis body structure

- Body weight considered as uniformly distributed load.
- Payload considered as uniformly distributed load
- Considering bending, torsion and combination of both, the body structure is designed allowing for a reserve factor depending in the road conditions.

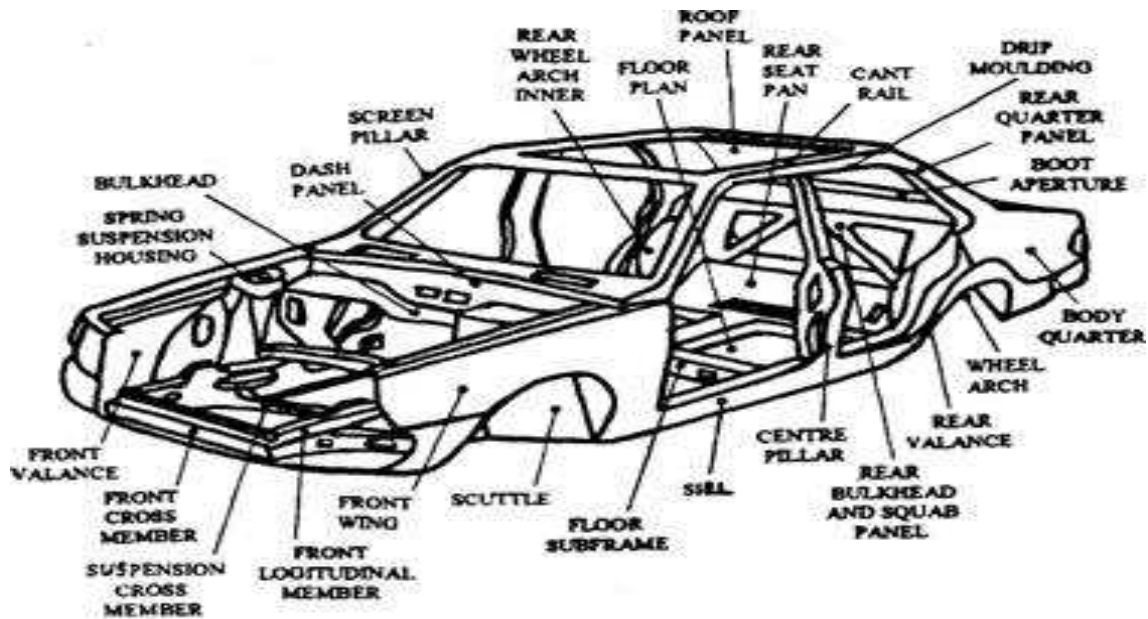

Advantages

- Light in weight compared with conventional type of body construction. so fuel consumption is less.
- Easy entry/ exit and lower floor height is to be achieved.
- Greater strength.
- Free from squeaks and rattles caused by the working of bolted joints which are absent in this construction.
- Reduction in heat in the driver and passenger area.
- Low noise and vibration level.
- Lowered wind screen level and better visibility for driver.
- Assembling of component is easy.
- Mainly this type is used in car construction.

Disadvantages

- When a car is involved in an accident, it is more expensive to repair the large panel sections.
- There is a greater liability of injury to the driver.
- It is more expensive to introduce changes in body styling to keep abreast of the times.
- Initial cost is more.
- Thick gauge material should be used.
- More money is required to avoid corrosion.

3. Semi – Integral Frame

- In some vehicles half frame is fixed in the front end on which engine gear box and front suspension is mounted. It has the advantage when the vehicle is met with accident the front frame can be taken easily to replace the damaged chassis frame. This type of frame is used in some of the European and American cars.

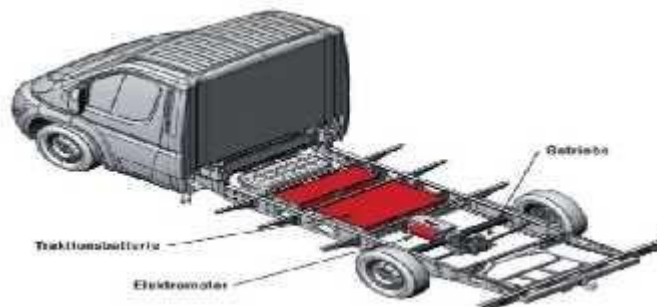

Various Types of Frame

Ladder Frame

- So named for its resemblance to a ladder, the ladder frame is the simplest and oldest of all designs. It consists merely of two symmetrical rails, or beams, and cross member connecting them.
- Originally seen on almost all vehicles, the ladder frame was gradually phased out on cars around the 1940s in favor of perimeter frames and is now seen mainly on trucks.
- This design offers good beam resistance because of its continuous rails from front to rear, but poor resistance to torsion or warping if simple, perpendicular cross members are used. Also, the vehicle's overall height will be higher due to the floor pan sitting above the frame instead of inside it.

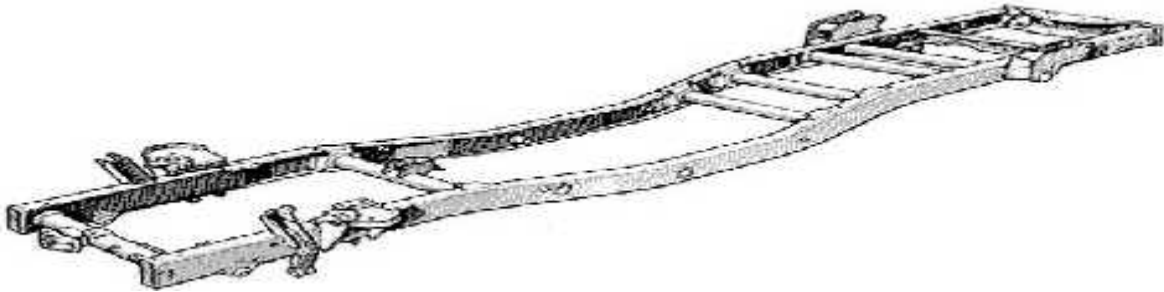

Backbone tube

- Backbone chassis is a type of an automobile construction chassis that is similar to the Body-on-frame design. Instead of a two-dimensional ladder type structure, it consists of a strong tubular backbone (usually rectangular in cross section) that connects the front and rear suspension attachment areas. A body is then placed on this structure.

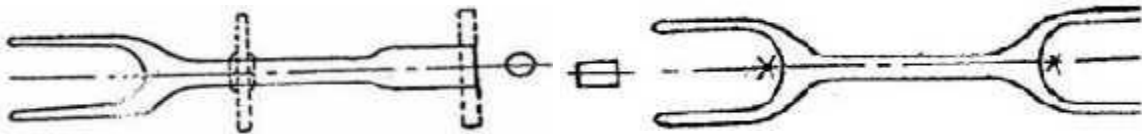

Perimeter Frame

- Similar to a ladder frame, but the middle sections of the frame rails sit outboard of the front and rear rails just behind the rocker panels/sill panels.
- This was done to allow for a lower floor pan, and therefore lower overall vehicle in passenger cars.
- This was the prevalent design for cars in the United States, but not in the rest of the world, until the unibody gained popularity and is still used on US full frame cars.
- It allowed for annual model changes introduced in the 1950s to increase sales, but without costly structural changes. In addition to a lowered roof, the perimeter frame allows for more comfortable lower seating positions and offers better safety in the event of a side impact.
- However, the reason this design isn't used on all vehicles is that it lacks stiffness, because the transition areas from front to center and center to rear reduce beam and torsional resistance, hence the use of torque boxes, and soft suspension settings.



Superleggera

- An Italian term (meaning "super-light") for sports-car construction using a three dimensional frame that consists of a cage of narrow tubes that, besides being under the body, run up the fenders and over the radiator, cowl, and roof, and under the rear window; it resembles a geodesic structure.
- The body, which is not stress-bearing, is attached to the outside of the frame and is often made of aluminum.



Unibody

- By far the most common design in use today sometimes referred to as a sort of frame. But the distinction still serves a purpose: if a unibody is damaged in an accident, getting bent or warped, in effect its frame is too, and the vehicle undrivable.
- If the body of a body-on-frame vehicle is similarly damaged, it might be torn in places from the frame, which may still be straight, in which case the vehicle is simpler and cheaper to repair.



Sub frame

- The sub frame, or stub frame, is a boxed frame section that attaches to a unibody. Seen primarily on the front end of cars, it's also sometimes used in the rear. Both the front and rear are used to attach the suspension to the vehicle and either may contain the engine and transmission.
- The most prolific example is the 1967-1981 Chevrolet Camaro.



X-frame

- This is the design used for the full-size American models of General Motors in the late 1950s and early 1960s in which the rails from alongside the engine seemed to cross in the passenger compartment, each continuing to the opposite end of the cross member at the extreme rear of the vehicle.
- It was specifically chosen to decrease the overall height of the vehicles regardless of the increase in the size of the transmission and propeller shaft humps, since each row had to cover frame rails as well.
- Several models had the differential located not by the customary bar between axle and frame, but by a ball joint atop the differential connected to a socket in a wishbone hinged onto a crossmember of the frame.
- The X-frame was claimed to improve on previous designs, but it lacked side rails and thus did not provide adequate side-impact and collision protection. This design was replaced by perimeter frames.

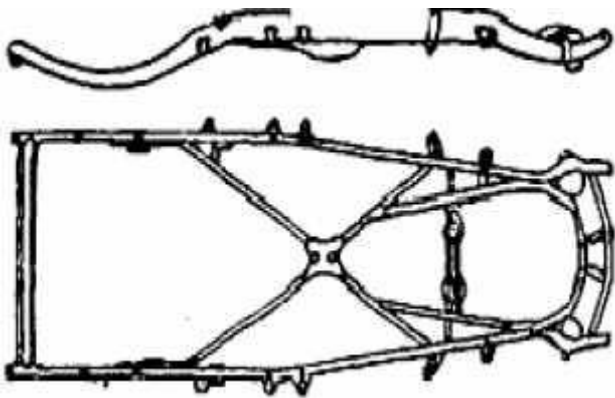

X-Frame



Rolling X-frame chassis

Frame Material

- ❖ Carbon – 0.25 – 0.35%
- ❖ Manganese – 0.35 – 9.725 %
- ❖ Silicon – 0.30 % (maximum)
- ❖ Nickel – 3%
- ❖ Phosphorous – 0.05 % (maximum)
- ❖ Sulphur – 0.5% (maximum)

3. EXPLAIN THE VARIOUS TYPES OF ENGINE

DRIVES OF AUTOMOBILES AND MENTION THE MERITS AND DEMERITS OF EACH DRIVE.

Some of the important drives of automobiles may be classified as follows:

- Front engine - Rear wheel drive
- Rear engine - Rear wheel drive
- Front engine - Front wheel drive
- Four wheel drive

1. Front Engine Rear Wheel Drive

- Rear wheel drive places the engine in the front of the vehicle and the driven wheels are located at the rear, a configuration known as front-engine, rear-wheel drive layout.
- In this layout a front mounted engine-clutch-gear box unit drives a beam type rear axle supported on leaf springs through a propeller shaft with two universal joints. With the help of coil springs, the front Wheels are independently sprung
- This layout is one of the oldest layouts which remain unchanged for many years.

Advantages

- Even weight distribution: Balanced weight distribution between the front and the rear wheels providing good handling characteristics.
- For easy front wheel steering movement engine occupies the reduced width between the wheel arches.
- Large luggage space is provided behind the rear seat.
- Maintenance and accessibility of engine, gear box is easy and the control over the accelerator, clutch, choke simple.
- Radiator cooling is natural (by air) so decreases the power required for cooling.

Better braking

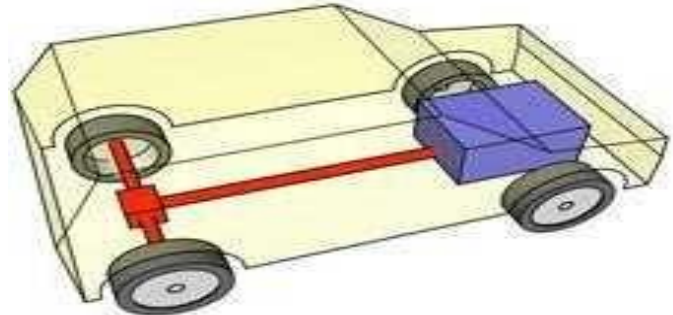
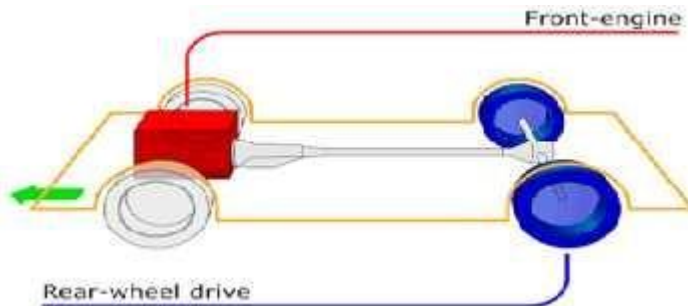

- efficiency : The more even weight distribution helps prevent lockup from wheels becoming unloaded
- Disadvantages:

- Reduces back seats leg room space,
- A tunnel is needed for the propeller shaft,
- Reduces boot space,
- Heavier and more expensive.
- If stuck in mud or snow it is harder to drive away than in a front wheel drive car.

2. Rear Engine Rear Wheel Drive

- This layout consists of placing the engine, clutch and gearbox in the back. So taking the space of the boot. In these type of layout more than 50% of the weight is on the rear axle.
- The necessity of the propeller shaft is completely eliminated. The clutch, gear box and engine and final drive form a single unit.

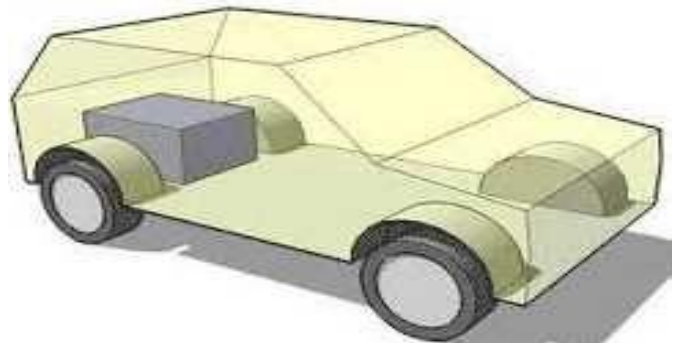
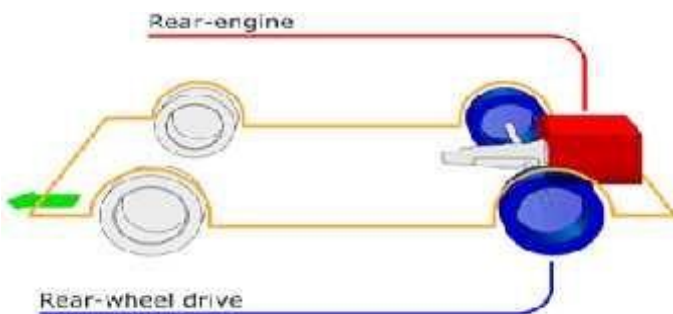

Advantages

- Excellent traction is available while climbing hills.
- A larger passenger space is available for the given length of body.
- Very compact and accessible power and transmission assembly is provided.
- Lot of weight at the back improves acceleration and braking, rear wheels and disc brakes can be designed to take a bigger amount of braking due to the weight distribution to the rear end.
- Passengers are comfortable from engine noise, heat and fumes.

- Front of the vehicle provides good visibility and by designing the body to aerodynamic shape gives good streaming lining.

Disadvantages

- At high speed, relatively high proportions of weight at the rear axle will make the car unstable at speed. There is a strong tendency for the vehicle to oversteer.
- The space at the front has to be reduced to allow for the steering lock of the front wheel.
- Space utilized for engine compartment is wasted.
- Difficulties with the arrangement of the engine cooling system. Natural cooling of radiator is not possible. Power requirement increases. Compact engine, clutch and gearbox make servicing more difficult.
- The wheels gets turn too sharply due to tendency of the vehicle to over steer. This necessitates the turning of the steering wheel in the opposite direction to make the correction by driver.

3. Front Engine Front Wheel Drive

- This type of arrangement provides optimum passenger space and a flat floor line resulting in a transverse under floor-longitudinal engine position.
- The propeller shaft length is reduced or neglects the propeller shaft.
- Good grip with road surface due to engine weight at front.
- Power required for the cooling is reduced. When the vehicle is to be 'steer in' to the curve, it provide 'under-steer' characteristics, which is always preferred.

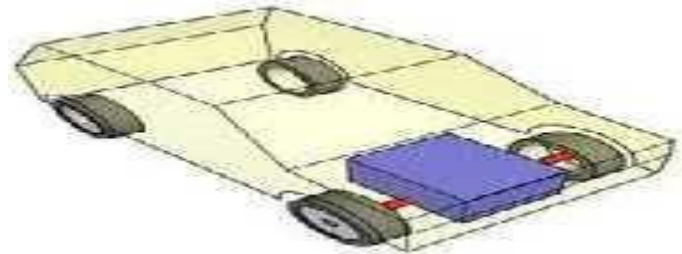
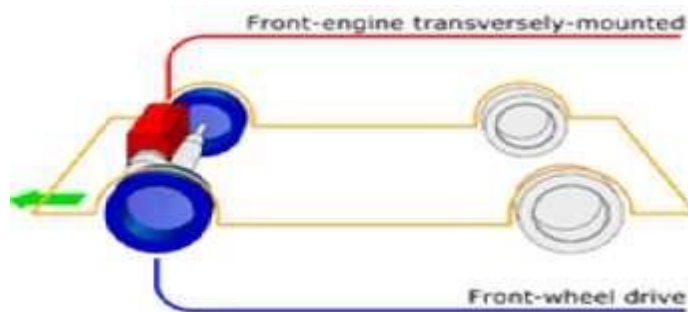

Advantages

- FWD cars have better traction while moving on the slippery roads like snow-covered roads because the engine is mounted above or near the front axle.
- These vehicles have compact design as the entire power-pack fits at the front of the vehicle.
- Due to the absence of propeller shaft and transmission tunnel, these cars have more interior space.
- Light-weight transmission reduces curb weight of the vehicle.
- As the front wheels of these vehicles receive engine power, they 'pull' the vehicle instead of a 'push' from the rear. Thus, passengers feel more stability in these vehicles.

Disadvantages

- Tyre wear on these vehicles is uneven. Front tyres wear out faster compared to rear tyres because of uneven weight distribution.
- While driving on roads with high slopes or during sudden acceleration, front wheels may experience loss of grip due to weight shift.

4. Four Wheel Drive

- In this arrangement all the four wheels of the vehicle are driven by the engine thus making the entire vehicle weight available for traction.
- These four wheel drive vehicles are very useful on Hill station if one of the wheel slipping or skidding then the other axle wheel transmit the tractive force to the vehicle. The steering of the four wheel drive is hard to operate compared with other type of drive.

Advantages

- Traction is nearly doubled compared to a two-wheel drive layout.
- Handling characteristics in normal conditions can be configured to emulate or R WD.
- Gives sufficient power, these results in unparalleled acceleration and drivability on surfaces with less than ideal and superior engine braking on loose surfaces.

Disadvantages

- The manufacturing cost of the vehicle is high.
- More component and complicate transmission.
- Increased power-train mass, rotational inertia and power transmission losses.
- Increased fuel consumption compared to 2WD.

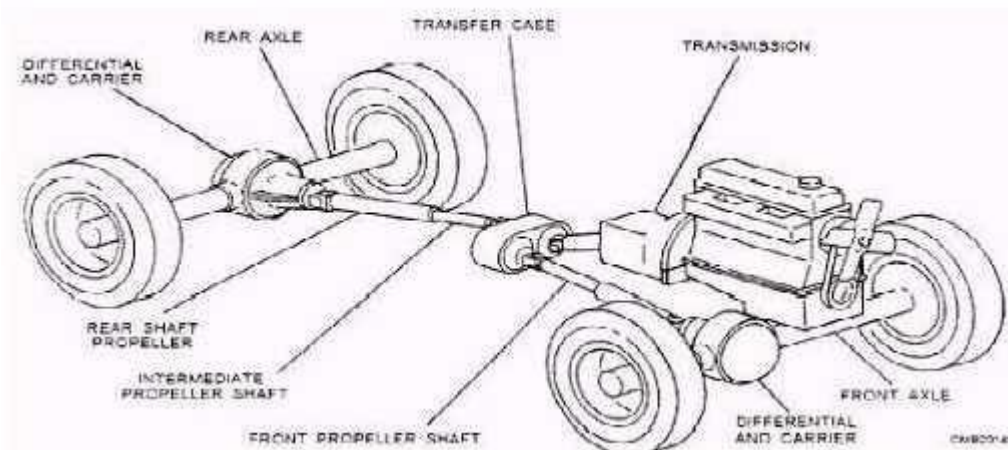
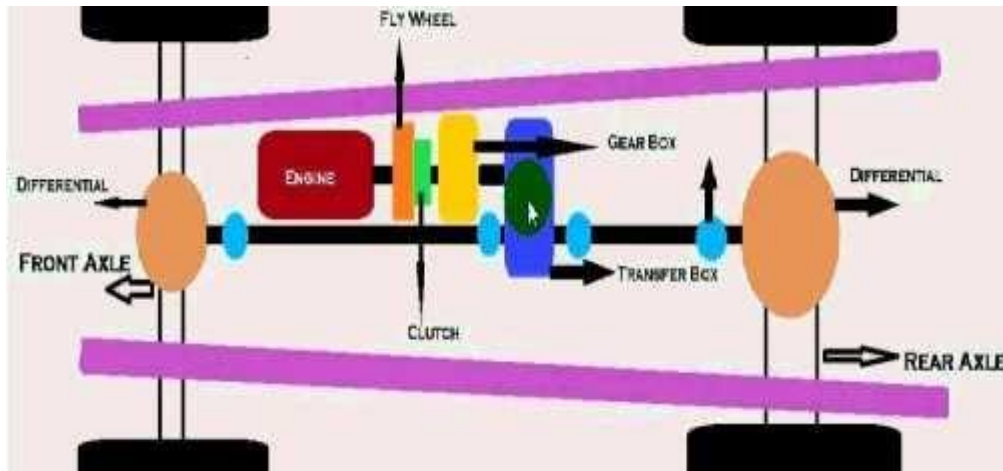

5. Mid-Engine, Rear Wheel Drive

- This type of engine layout places the engine between the two axles and the rear wheels are driven. weight is equally distributed between front and rear wheel

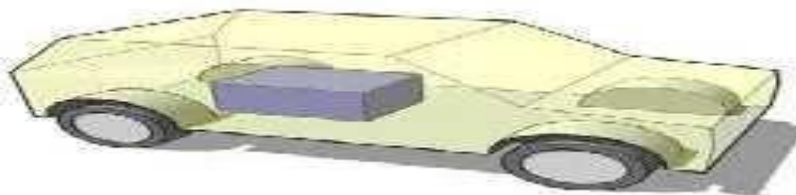

Advantages

- Good acceleration because of back weight transfer.

- Efficient braking.
- Neutral handling.

Disadvantages

- When accelerating some steering is lost.
- Require more space.
- No back seats.
- Difficulties with the cooling system.

Rear engine, all wheel drive (4WD) :

Similar characteristics as rear engine, rear wheel drive. And other additional as:

Advantages

- Better weight distribution.
- More neutral reactions.
- Better traction on bends and slippery road surfaces.

Disadvantages

- Heavier.
- More expensive and difficult to design and build.

Front engine, all wheel drive(4WD) :

Similar characteristics as the front engine, rear wheel drive Plus .

Advantages

- Better handling capacity.
- Better acceleration.

Disadvantages

- It increases weight and manufacturing cost compare with front engine layouts.
- Loss of some space in the back seats legs room.

Differentiate between front and rear mount engine vehicle:

Front mount Engine (F), Rear mount Engine(R)

- F: Travelling is faster and safer as compare to rear mount engine.
R: Travelling is less fast and safer than front mount engine.
- F: This engine vehicle has good road adhesion due to large vehicle weight carrying on driving wheel.
R: This engine vehicle having less road adhesion as compared to front mount engine.
- F: This engine provide less passenger comfort compared to rear mount engine.
R: This engine provides better passenger comfort due to reduce noise, heat and fumes.
- F: It provides high floor results in more passenger space as compared to rear engine.
R: It provides less floor area result in more passenger space due to dispensing with propeller shaft.
- Front engine vehicles provide natural air cooling.
Rear engine required powerful fan.
- F: In this engine as compared to the rear engine the vehicles are less affected.
R: In this engine, the rearward concentration of weight causes the vehicle more affected by side
- F: Chance of wheel skidding is less.
R: Chance of wheel skidding is more.
- Front engine vehicles visibility is poor.
Rear engine vehicles visibility is good.

Most of the modern cars are front wheel drive

- This type of arrangement provides optimum passenger space and a flat floor line resulting in a transverse under-floor-longitudinal engine position.
- The propeller shaft length is reduced or neglects the propeller shaft.

- Good grip with road surface due to engine weight at front.
- The chance of wheel skidding and slipping is very much reduced.
- Natural air-cooling of the radiator due to motion of vehicle.

Articulated Vehicles

- These vehicles having a detachable trailer supported on a platform on the tractor unit are used to carry heavy loads which must not exceed gross train weight.
- The trailer tractor connection is also called the fifth wheel. Its maximum permitted laden length and weight is 15 meters and 20 tonnes or less than four wheel vehicle. No time will be waste in loading or unloading as several trailers are available.

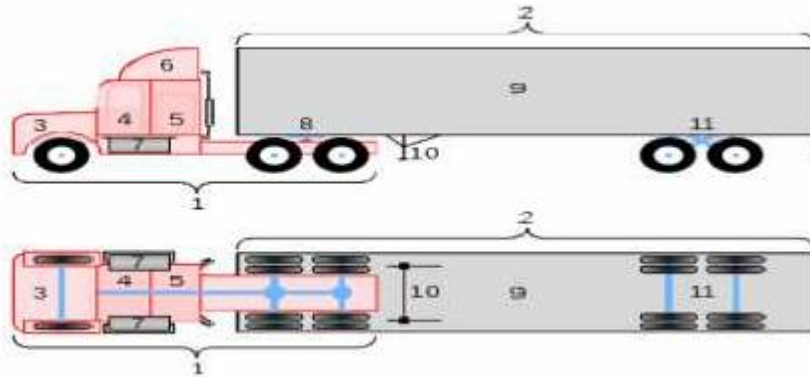

Heavy Commercial Vehicles

- These heavy and robust vehicles used for haulage purpose are powered by a diesel engine.
- Its gross vehicle weight (g.v.w.) is more than 3 tonnes. It required twin tyres fitted side by side on the rear wheels for carrying heavy loads. Sometimes, more axles are added for very heavy loads.
- All the power and transmission components are arranged in a driver compartment. Depending upon the requirement they may be open or closed body. The open body vehicles are known as light truck or pick up.

Left hand and Right and drives

- In different countries, the automobiles are driven on different sides of the road, In United Kingdom and all the countries, which were once colonies of the British Rule. The vehicles are driven on the left hand side of the road.
- In all other countries of the world, normally vehicles are driven on the right hand side of the road. For better driving control, the vehicle drivers must be nearer to one another while passing or crossing. Similarly for safety consideration, the drivers must be in the centre of the road while driving.
- Therefore, two types of vehicles are manufactured.
- Left hand drive: The steering is fitted on the left hand side of the automobile and such vehicles are convenient to drive in countries following right hand drive rules, e.g. U.S.A., Russia, European countries.
- Right hand drive: The steering is fitted on the right hand side of the automobile and such vehicles are convenient to drive in countries following left hand drive rules, e.g. U.K., India, Pakistan. However, though rare, left hand cars also driven in such countries.

Front wheel steering Rear wheel drive

- Access to the engine is very easy.
- Slowing down of the water circulation causing cooling troubles can be avoided and long hose connections can be saved due to situating of the radiator in the main air stream.
- This arrangement helps minimize the linkage between the clutch, gear box and engine.
- The angularity of the propeller shaft is kept to minimum and there is no need of joints due to the shaft length.

4. EXPLAIN THE VARIOUS FORCES ACTIONG ON THE BODY AND ITS AERODYNAMICS AFFECTS. (OR) RESISTANCES TO VEHICLE MOTION

The following forces act on vehicle in motion:

Aerodynamic drag:.

- Aerodynamic means the behavior of the air motion relative to the car body. Aerodynamic drag is also called as air resistance.
- Air drag force acts in the direction of vehicle motion.
- The total aerodynamic drag of a vehicle include many factors such as profile drag (57%), induced drag (8%), skin friction (10%), interference drag (15%) and cooling and ventilation drag (10%).
- Stream line of air flow around the vehicle should be continuous and separation of the boundary layer with its attendant vertices should be avoided. Skin drag coefficient should be decrease by smooth and well-polished of body surface.
- The accessories such as mirror, door handle aerals and badges which project outward from normal surface of body produce interference drag and projection below the vehicle such as axle, propeller shaft, tow bar also contribute interference drag hence such projection should be avoided.

Aerodynamic lift

- It is the vertical component of the resultant force caused by the pressure distribution on the vehicle body.
- The aerodynamic lift and pitching moment are undesirable effects. The aerodynamic lift tends to reduce the pressure between the tyre and the ground. This causes the loss of steering on the front axle and loss of traction on the rear axle.
- Pitching causes rear wheel lift off the ground and reduces available traction. It is the rocking chair or rotating action about the transverse axis through the vehicle parallel to ground. Due to pitching, the front suspension moves out of phase with the rear resulting in rocking effect in a vehicle.

Side force

- The imbalance of the wheel due to centrifugal force acts on the vehicle during turning which produces a side thrust.
- To sustain that force, the plane of the wheel makes some angle with the direction of motion of the vehicle. This is achieved by the direction of tyre which is flexible.
- The angle form during taking turn to sustain the side thrust is known as slip angle and the force produce to counter acts the side thrust is called as cornering force.

Yawing movement (Bouncing)

- It is vertical movement of the complete body .When complete body of vehicle goes up and down which is known as bounce or bouncing. Depending upon the movement of front end or rear end the bounce is known as front end bounce or rear end bounce.

Rolling movement

- It is the movement of a vehicle about its longitudinal axis produced due to centrifugal force act during cornering.
- The retarding and cornering forces are applied at road levels but the centre of gravity of a vehicle is at a certain height. During cornering, a turning couple is produced about the longitudinal axis of the vehicle owing to centrifugal force acting at centre of gravity and forces acting at the point of contact of road and tyre patch. This results in a motion known as rolling.
- A combination of rolling and pitching is called diagonal pitch.

Remedies:

- In order to control all the above suspension movements; anti roller bar, stabilizer, pitch and roll control bars, hydraulic systems, mechanical levelling devices etc. are provided to vehicles.

Aerodynamics

- It is a branch of dynamics concerned with studying the motion of air, particularly when it interacts with a solid object, such as an Automobile, airplane wing, etc.

- Aerodynamics, from Greek $\alpha\eta\rho$ aer (air) + $\delta\upsilon\nu\alpha\mu\iota\kappa\acute{\eta}$ (dynamics), is a branch of dynamics concerned with studying the motion of air, particularly when it interacts with a solid object, such as an airplane wing. Aerodynamics is a sub-field of fluid dynamics and gas dynamics, and many aspects of aerodynamics theory are common to these fields.
- The term aerodynamics is often used synonymously with gas dynamics, with the difference being that "gas dynamics" applies to the study of the motion of all gases, not limited to air. Modern aerodynamics only dates back to the seventeenth century, but aerodynamic forces have been harnessed by humans for thousands of years in sailboats and windmills, and images and stories of flight appear throughout recorded history, such as the Ancient Greek legend of Icarus and Daedalus.
- Fundamental concepts of continuum, drag, and pressure gradients, appear in the work of Aristotle and Archimedes. Forces of flight on an airfoil

Fundamental Concept

- Understanding the motion of air around an object (often called a flow field) enables the calculation of forces and moments acting on the object. In many aerodynamics problems, the forces of interest are the fundamental forces of flight: lift, drag, thrust, and weight. Of these, lift and drag are aerodynamic forces, i.e. forces due to air flow over a solid body.
- Calculation of these quantities is often founded upon the assumption that the flow field behaves as a continuum. Continuum flow fields are characterized by properties such as velocity, pressure, density and temperature, which may be functions of spatial position and time.
- These properties may be directly or indirectly measured in aerodynamics experiments, or calculated from equations for the conservation of mass, momentum, and energy in air flows. Density, velocity, and an additional property, viscosity, are used to classify flow fields.
 - ❖ Air Resistance
 - ❖ Gradient resistance (Vehicle weight but depend on the speed of the vehicle)
 - ❖ Rolling Resistance
 - ❖ Miscellaneous resistance
 - Road characteristics
 - vehicle speed
 - Tyre characteristics

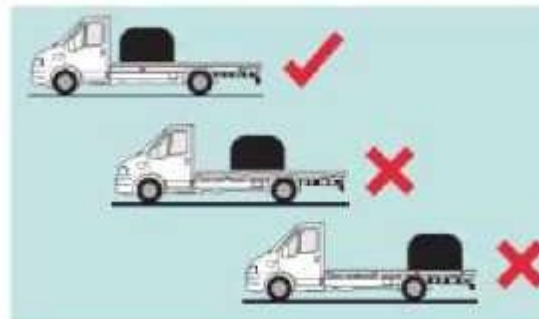
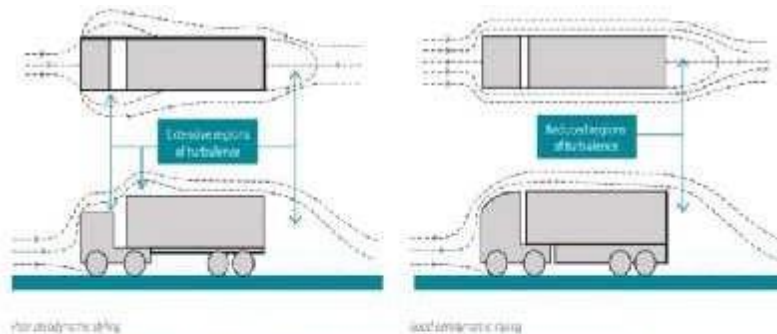

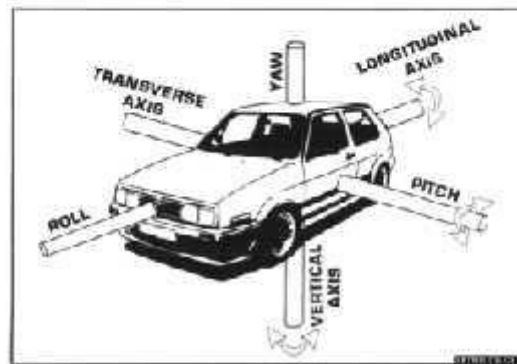
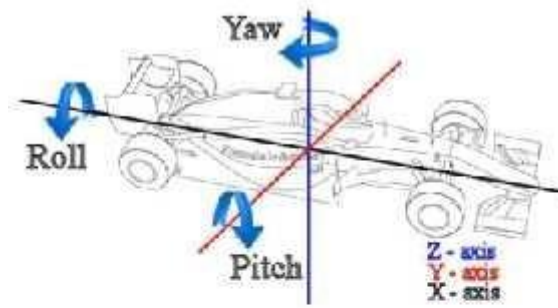

Forces and moments acting on a vehicle

Air Resistance:

- This is the resistance offered by air to the movement of a vehicle.
- The air resistance has an influence on the performance, ride and stability of the vehicle and depends upon the size and shape of the body of the vehicle, its speed and the wind velocity.
- The last term should be taken into account when indicated, otherwise it can be neglected. Hence in general, air resistance,

Rolling Resistance:

The magnitude of rolling resistance depends mainly on

- the nature of road surface,
- the types of tyre viz. pneumatic or solid rubber type,
- the weight of the vehicle, and
- the speed of the vehicle.

FORCES ACTING ON VEHICLE :

- Drag force (F_x)- Along the vehicle direction Profile drag, interference drag, skin friction, cooling and ventilation system drag.
- Cross wind (F_y)- along side or lateral direction Asymmetric flow of air around the vehicle body
- Lift force(F_z) – vertical force acting from the bottom of the vehicle. Because of pressure difference between top and bottom of the vehicle.

MOMENTS DUE TO FORCES:

Moments created by forces acting on the vehicle

- Pitching moment – Created by drag or lift force about y-axis and reduces the traction in the wheels
- Yawing moment- Created by cross wind about z-axis
- Rolling Moment – Created by cross wind about x-axis

5. CLASSIFICATION OF A VEHICLE CHASSIS IS BASED ON THE POSITION OF THE ENGINE ON THE CHASSIS.

- Full forward chassis
- Semi Forward chassis
- Engine at centre chassis
- Engine at the back chassis
- Conventional chassis

Full Forward:

- Mostly power is given to the front wheels hence reduces components
- Problem of visibility & Costly because of transaxle
- Part of Chassis portion cannot be utilized for carrying passengers and goods



Semi Forward:

- Half portion of the engine is in the driver cabin and remaining half is outside the cabin such as in tata trucks
- In this arrangement a part of the chassis is utilized for carrying extra passengers



Engine at Centre:

- Drive is given to the rear
- Full space of the chassis floor can be used (Royal tiger world master buses in Delhi)
- If used in cars it limits the car to be a two seater.
- Luxury/Sports cars use this layout.

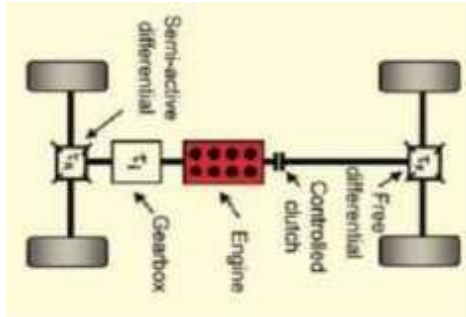

Engine at the rear/back:

- Reduced components
- Costly because of transaxle
- With elimination of propeller shaft the centre of gravity lowered giving stable driving
- Better adhesion on road specially when climbing hill.



6. EXPLAIN IN DETAIL ABOUT THE VARIOUS COMPONENTS OF ENGINE WITH NEAT SKETCHES.

Basic engine parts with its pictures

- In this post, we will discuss the engine parts. As you know that an engine is a machine designed to convert one form of energy into mechanical energy. Heat engines burn a fuel to create heat which is then used to do work. The engine has two types one is the internal combustion engine and another one is external combustion engine.
- The internal combustion engine is those heat engines that burn their fuel inside the engine cylinder.
- External combustion engines are those heat engine that burns their fuel outside the cylinder engine.
- The engine most essential part of automobile industries or we can say that the engine is the heart of an automobile.

Terms connected with i.c. engines

- Bore: The inside diameter of the cylinder is called bore
- Stroke: The linear distance along the cylinder axis between two limiting positions is called stroke.
- Top Dead Center (T.D.C.) : the top most position of the piston towards cover end side of the cylinder is called T.D.C.
- Bottom dead Center (B.D.C.) : The lowest position of the piston towards the crank end side of the cylinder is called B.D.C.
- Clearance Volume: The volume contained in the cylinder above the top of the piston , when the piston is at top dead center , is called the clearance volume.
- Swept Volume: The volume swept through by the piston in moving between T.D.C. and B.D.C, is called swept volume or piston displacement.
- Compression Ratio: It is the ratio of Total cylinder volume to clearance volume

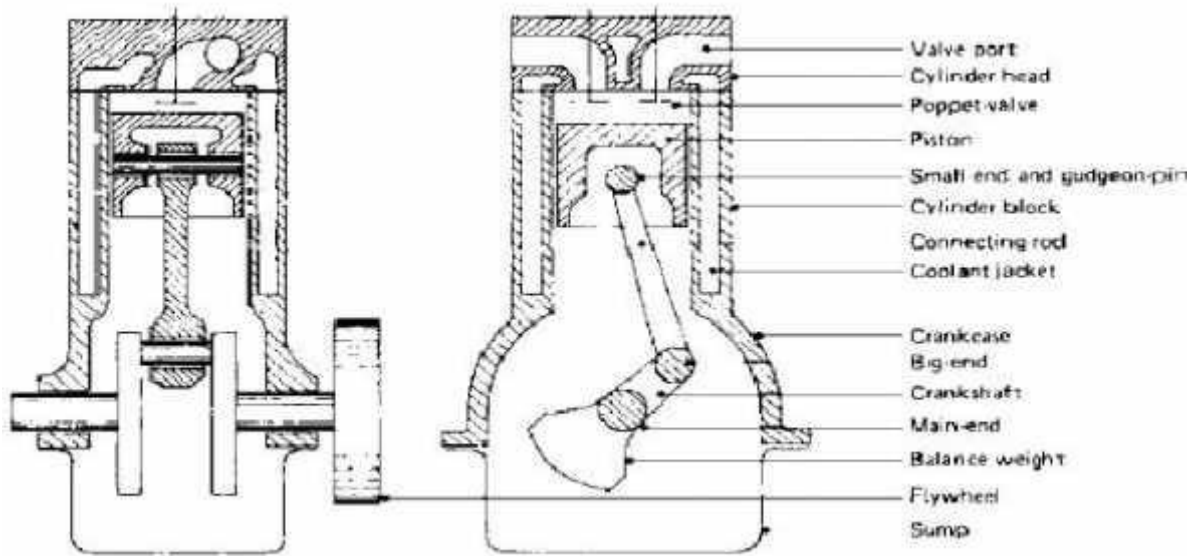

➤ The function and construction of each engine parts of an internal combustion engine are explained. The key to the engine are as follows:

The main engine parts are as follows:

- ❖ Cylinder Block
- ❖ Cylinder Head
- ❖ Crank Case
- ❖ Oil Pan
- ❖ Manifolds
- ❖ Gasket
- ❖ Cylinder Liner
- ❖ Piston
- ❖ Piston Clearance
- ❖ Piston Ring
- ❖ Connecting Rod
- ❖ Piston Pin
- ❖ Crank Shaft
- ❖ CamShaft
- ❖ Flywheels
- ❖ Engine Valves
 - ✓ Poppet valve
 - ✓ Sleeve valve
 - ✓ Rotary valve
- ❖ Governors

1. Cylinder block

➤ Fig shows a simple sketch of the cylinder block. It is the basic framework for the engine. and one of the main in engine parts. Cylinder block, cylinder head and crankcase these three parts form the foundation and main stationary body of the automobile engine.

A cylinder block consists of three parts:

- The cylinder in which the piston slid up and down.
- The port or opening for the valves.

- The passages for the flow of cooling water.

Construction and working:

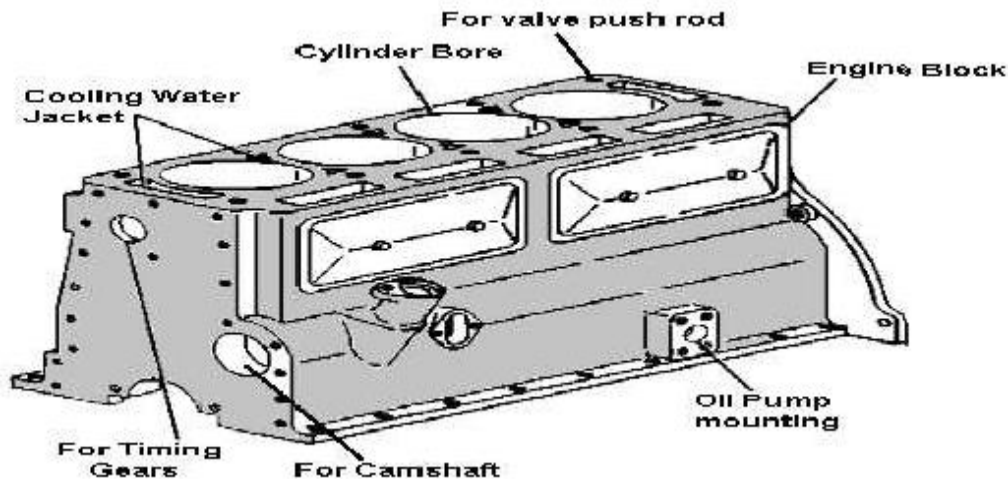

- The cylinder block is usually made of grey cast iron or aluminum and its alloys.
- While the crankcase is fixed to its bottom. Apart from these other parts like timing gear water pump, ignition distributor, flywheel, fuel pump etc., are also attached to it.
- Passages are provided in the cylinder walls for the circulation of cooling water.
- Mating surfaces of the block are carefully machined to provide a perfect sealing surface.
- Cylinder block also carries lubrication oil to various components through drilled passages called oil galleries.

2. Cylinder Head

Another type of engine parts is cylinder head it is joint between the cylinder head and cylinder block.

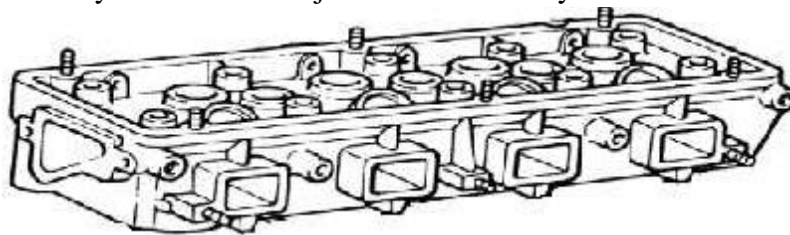

Construction:

- It is usually made up of cast iron and aluminum alloy.
- The top of the cylinder is covered by a separate cast piece know as the cylinder head.
- The cylinder head is attached to the cylinder block by means of studs fixed to the block Gaskets are used to provide a tight, leak-proof joint between the head and block.
- It contains a combustion chamber above each cylinder.
- It also contains valve guides, valve seats, ports, coolant jackets and threaded holes for spark plugs. It incorporates passages for the flow of cooling water.

Applications:

- The cylinder head casts integrally with cylinder blocks also be done in a few cases usually in racing cars to obtain a gas-tight joint.
- The detachable head types are more advantages than the integral construction.
- However, for certain heavy-duty engine requires high cooling rates such as in racing cars copper alloys may be used.

Depending upon the valve and port layout, the cylinder head may be classified into three types as follows:

- ❖ Loop flow type

- ❖ Offset cross flow type
- ❖ Inline cross flow type

Loop flow type: In the loop, flow types the inlet and the exhaust manifolds are on the same side, which facilitates preheating of the intake air.

Offset cross flow type: Offset cross flow types the inlet and the exhaust manifolds are placed on different sides of the cylinder head.

In line cross flow type: In line cross-flow type, the valve is positioned transversely and usually inclined to each other, while the inlet and the exhaust manifolds are on different sides of the cylinder head. This arrangement gives better performance, but it is costlier.

3. Crankcase

The oil pan and the lower part of the cylinder block together are called the crankcase. It is the bottom portion of the cylinder block, in which the crankshaft is fitted.

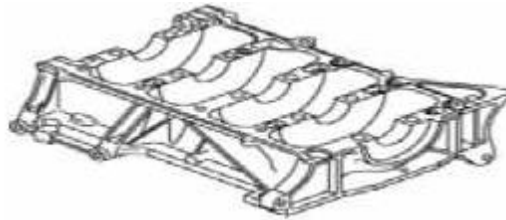

Construction:

- This is a rigid construction made of grey cast iron or aluminum. Either it can be cast integrally with the block or can be cast separately and attached to the block with bolts.
- The crankcase is shaped simply like a box having no bottom. Oil pan or sump forms the bottom half of the crankcase.

Working:

- The function of the crankcase is to provide support for the main journals and bearing of the crankshaft, rigidly maintaining the alignment of their axes of rotation under various engine loads.
- The crankcase is supported in the crankcase through a number of bearing called the main bearing.

4. Oil Pan

The bottom half of the crankcase is called the oil pan or sump. It is attached to the crankcase through set screws and with a gasket to make the joint leak proof.



The oil pan serves as a reservoir for the storage, cooling and ventilation of engine lubricating oil.

At the bottom of the oil sump, a drain plug is provided to drain out the dirty oil at the time of oil replacement.

Generally, the sump is made of pressed steel sheet or aluminum alloy casting is used.

The various functions of the oil pan as follows.

- To store the oil for the engine lubrication system.
- Oil pan used to collect the return oil draining
- To serve as a container for impurities or foreign matters

- Oil pan provides for cooling of the hot oil in the sump.

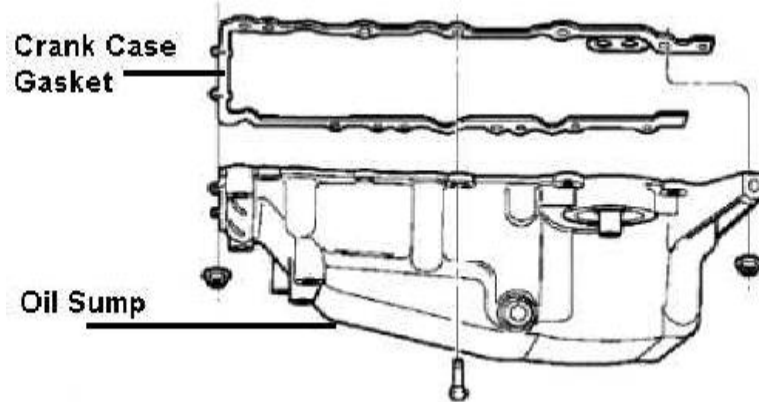

Working:

- The oil pump in the lubricating system draws oil from the oil pan and sends it to all working parts in the engine.
- The oil drains off and runs down into the pan.
- Thus there is a constant circulation of oil between the pan and the working parts of the engine.

5. Manifolds

There are separate sets of pipes attached to the cylinder head which carry the air-fuel mixture and the exhaust gases. These are called manifolds. It is generally made of cast iron so that it is able to withstand the high temperature of the exhaust gases.



Construction:

- It consists of the air intake, throttle body, intake manifold flange for tail-pipe and flange for a carburettor.

Working:

- The air goes into the air intake travels through, throttle body into the intake manifold and from there it goes into the engine through the cylinder head.
- The inlet manifold carries the air-fuel mixture from the carburettor to the cylinders.
- The exhaust manifold is the set of pipes carrying exhaust gases from the cylinder head to the exhaust system.

6. Gaskets

Gaskets are used to provide a tight fitting joint between two surfaces.

Gaskets are found in:

- the joint between the cylinder head and the cylinder block
- Between crankcase and oil pan.
- Between the cylinders block and manifold.



The various materials used for gaskets are:

- Cork
- Asbestos
- Rubber

Some of the requirement/properties of the gasket as follow:

- Conformity: The gaskets should conform to the mating surfaces which may have roughness or warpage.
- Resistance: It should have resistance to high pressures, extreme temperature and vibrations.
- Impermeability: The gasket must be impermeable to the fluid.
- Resistance to chemical attack: the gasket should have resistant to the chemicals such as fuel, products of combustion, coolant and engine oil.
- Provision of apertures: The gasket must have apertures for any studs, bolts, opening etc.,

Some of the gaskets produced by the fuel-pro USA as follows:

- Cylinder head gaskets.
- Oil pan gaskets.
- Manifold gaskets.
- Pump gaskets.

Following important gaskets are used in automobile engines:

- Copper-asbestos gasket.
- Steel-asbestos gasket.
- Steel-asbestos-copper gasket.
- Single steel ridged or corrugated gasket.
- Stainless steel gasket.

7. Cylinder liners

These are cylindrical shapes used in the cylinders to avoid the problem of cylinder wear. It is one of the most important functional parts to make up the interior of an engine. These can be replaced after they worn-out. These are made of special alloy iron containing silicon, manganese, nickel and chromium. Usually, these are cast centrifugally. These liners resistance to wear and corrosion. These liners are of the oil hardening type and offer considerably longer life for the engine.



Cylinder liners are of two types:

Dry liners and wet liners. Let's take the detail view.

Dry liners:

Construction: The construction of a dry liner is shown in the fig. This liner is made in the shape of a barrel with a flange at the top which keeps it into position. The entire outer surface bears against the cylinder block casting and hence these are to be machined accurately at both outer and inner faces. The liner should not be too loose, otherwise, the heat dissipation becomes poor because of the absence of good contact with the cylinder block.

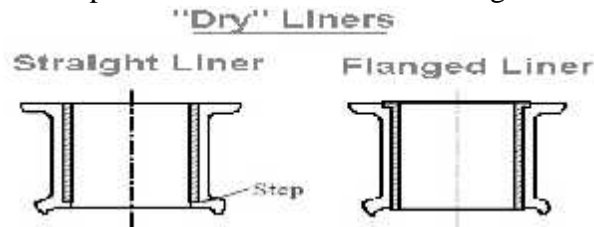

Wet liners:

These liners will be in direct contact with the cooling water at their outer face. Thus, These liners need not be machined very accurately at the outer surface. However, they have been machined accurately at the inner surface. They are resisting corrosion with continuous contact with cooling water. and they coated with aluminium at their outer surface.

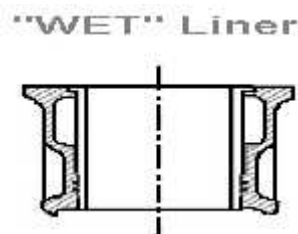

Construction:

- At the top, the liner is provided with a flange which fits into the groove in the cylinder block.
- At the bottom of the liner is provided with a groove, generally three in number.
- The middle groove is left empty for drainage for any water that may leak from the upper ring.
- And in the top and bottom ones are inserted packing ring, made of synthetic rubber.

Comparison of the dry and wet liner:

Dry Liners

- Dry liners may be provided either in the original design or even afterwards.
- The construction of cylinder block very complicated. The cooling effect is not very good.
- Accurate machining of dry liners for perfect contact with the cylinder casting is essential.
- In this type, it cannot be finished before fitting. A leak-proof joint is not necessary.

Wet Liners

- Wet liners have to be included in the original design. The construction of the cylinder block is simple.
- The cooling effect is better because the liner will have direct contact with cooling water.
- Accurate machining is not essential. In this type, they can be finished before fitting.
- A leak-proof joint should be made between wet liner and cylinder block.

8. Pistons

Pistons are most important engine parts compared to other. The piston is a cylindrical plug that moves up and down in the cylinder. It helps to convert pressure energy obtained by the combustion of fuel into useful mechanical power and it transfer this power to the crankshaft through the connecting rod.

- The highest position of the piston reaches in the cylinder is called the Top Dead Centre(TDC) and
- The lowest position it reaches is called the Bottom Dead Centre(BDC).

It is provided with pistons ring about 3 to 5 provide a good seal between the cylinder wall and piston.

The efficiency and economy of the engine primarily depend on the working of the piston. The material used for the piston is mainly.

- Cast iron,
- Aluminium alloy.
- Nowadays aluminium alloys are widely used. It may be either cast or forged.



The piston must possess the following qualities:

1. Rigidly to withstand high pressure
2. Light in weight, to reduce the reciprocating mass to perform at higher engine speed.
3. Good heat conductivity.
4. Less noise while operating.

9. Piston clearance

The piston is usually a small in diameter than the bore of the cylinder. The space between the cylinder and the cylinder wall is called the piston clearance. This piston clearance provides a space for a layer of lubricant between the piston and cylinder wall to reduce friction.

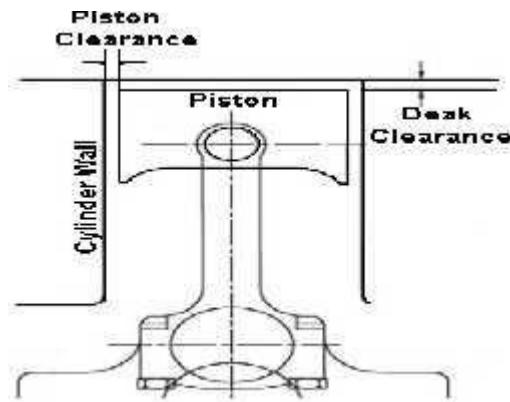

Generally, piston clearance is

- 0.025mm to 0.100mm.

Proper clearance should be maintained between the piston and the cylinder wall.

- If the clearance is too small, there will be a loss of power from excessive friction, more wear, seizing of the piston in the cylinder.
- If the clearance is too much, piston slap will result. Piston slap means sudden tilting of the cylinder as the piston moves down during the power stroke.

It prevents piston seizure due to high temperature. If there is no clearance then it is not possible to reciprocate piston inside the cylinder.

Functions of piston:

some of the important function of the piston as follows

- To transmit the power developed by fuel combustion to the crankshaft through the connecting rod.
- To form a seal so that high-pressure combustion gases do not escape to the crankcase.
- To serve as a support for the small end of the connecting rod.
- To suck the charge and push out the exhaust gases.

Constructional Features:

The cross-section of a piston is shown in the fig.

- The top of the piston is called head or crown.
- Towards the top of the piston, a few grooves are cut to house the piston rings. The bands left between the grooves are known as lands.
- The part of the piston below the ring is called Skirt is provided with bosses on the inside to support the piston pin (Gudgeon pin).
- The distance between the axis of the piston pin and the top of the piston crown is called compression height.

Type of pistons:

The various types of pistons are classified depending on the shape, design, operation. The important types of the piston as follows.

- ❖ Cast Pistons
- ❖ Forged pistons
- ❖ Cast Steel Piston
- ❖ BI-metal piston
- ❖ Two-piece piston
- ❖ Oil-cooled pistons
- ❖ Anodized piston
- ❖ Tinned pistons

Piston materials: Cast Iron, Aluminium, Lo-Ex Alloy, Invar, Steel alloy.

Protective coating: Cadmium plating, Anodised Pistons, Tinned pistons, Chromium plating.

10. Piston Rings



Piston rings are fitted into the grooves of the piston to maintain a good seal between the piston and the cylinder wall. The number of piston rings used is about 2 to 4 compression rings and 1 to 2 oil control ring was used but in modern design the number of rings usually three out of which one is the oil control ring.

The function of piston rings:

- To form a seal for the high pressures gases from the combustion chamber entering into the crankcase.
- To provide easy passage for heat flow from the piston crown to the cylinder walls.
- To maintain sufficient lubrication oil on cylinder walls throughout the entire length the piston travel, hence it minimizes the cylinder wear.

Construction:

Fig showed the piston ring construction:

- The ring is generally cast individually and machined carefully so that when in the position it is able to exert uniform pressure against the cylinder walls.
- A gap has been cut at the end.
- In practice, the piston ring end gap when installed is kept about 0.30 to 0.35 mm.
- The gap is almost closed when the piston is inside the cylinder, so that piston and cylinder.

The piston ring end gap may be:

- Butt type
- Taper type
- Lap type

Material for piston rings:

The material generally used for piston rings is

- fine-grained alloy cast iron containing silicon and manganese. It has good heat and wears resisting qualities.

Chromium plated rings are also used for the top ring, which is subjected to the highest working temperatures and the corrosive action of the combustion products.

Types of Piston Rings:

Mainly there are two types of piston rings as follows.

- Compression rings: Fig shown a simple sketch of Compression rings. these rings effectively seal the compression pressure and the leakage of the combustion gasses. these are fitted in the top grooves. They also transfer heat from the piston to the cylinder walls.
- Oil control rings: The Figure shows a simple sketch of oil control ring. The main purpose of the oil ring is to scrape the excess oil from the liner and return it back to the oil sump during the downward and upward movement of the piston. It prevents the oil from reaching the combustion chamber. One of two oil control rings is used in a piston. If two rings are used one has fitted above and other is fitted below the gudgeon pin in the piston. These rings are provided with drain holes or slots. these slots allow the scraped oil to reach into the oil sump through the piston holes.

Read also: Piston Ring Maintenance – marineinsight.com

11. Connecting Rod

Fig showed a connecting Rod. It is fitted in between the piston and crankshaft. The main function of the connecting rod is to convert the reciprocating motion of the piston into the rotary motion of the crankshaft. It must be light and strong enough to withstand stress and twisting forces.

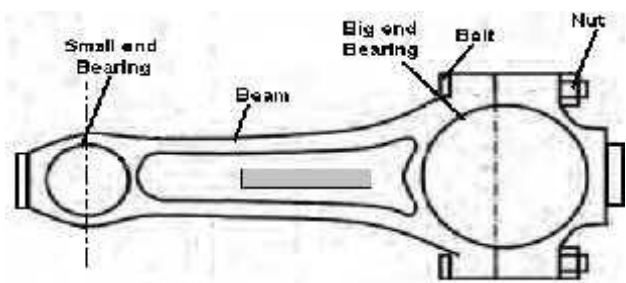

Construction:

- The connecting rod usually has I-beam cross-section and is made of alloy steel or duralumin by drop forging.
- Nowadays it is also cast from malleable or spheroidal graphite C.I.
- The small end of the connecting rod has either a solid eye used to connect the piston by the piston pin.
- The big end of the connecting rod is always split is used to connect the crank pin of the crankshaft.

12. Piston Pin



The piston pin is also called wrist pin or gudgeon pin. It is used for connecting the small end of the connecting rod and the piston.

Construction: It is made hollow to reduce weight and it is made from case hardened steel.

Mainly there are three types of piston pins as follows.

- Set screw types piston pin.
- Semi-floating piston pin
- Fully floating piston pin

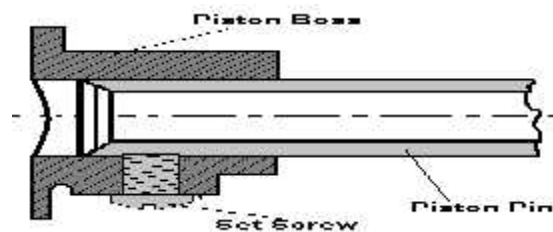

Above Fig shown Set screw type piston pin, This pin is fastened to the piston by a SET SCREW such that the connecting rod end swivel has required by the combined reciprocating and rotary motion of the piston and crankshaft.

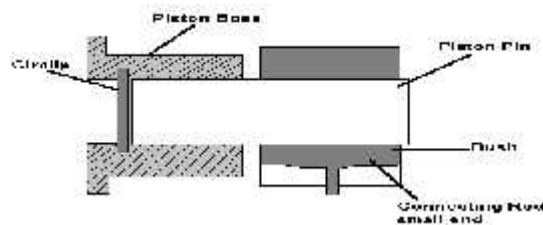

Above Fig shown the Semi-floating piston pin, It is fastened to the connecting rod with a clamp screw.

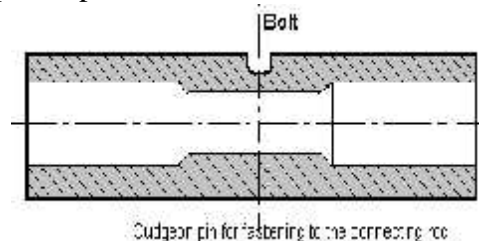

Above Fig shown Fully floating piston pin. The pin floats in both the piston bosses and the small end of connecting rod. It is prevented from coming in contact with the cylinder wall by two circlips.

13. Crankshafts

The crankshaft is the engine component from which the power is taken. It is one of the main power transmission sources in all engine parts. The Crankshaft is the first part of the power transmission system in which the reciprocating motion of the piston is converted into the rotating motion with the help of connecting rod.

Construction:

- The crankshaft is made of casting or forging of heat treated alloy steel and is machined.
- A crankshaft consists of crankpins, webs, balancing weight and main journals and oil holes.
- The big end of the connecting rod is connected to the crankpin of the crankshaft.

- Centre to centre distance between the crankpin and crankshaft is half of the piston displacement during the stroke.

Thus one complete revolution of the crankshaft makes two strokes of the piston.

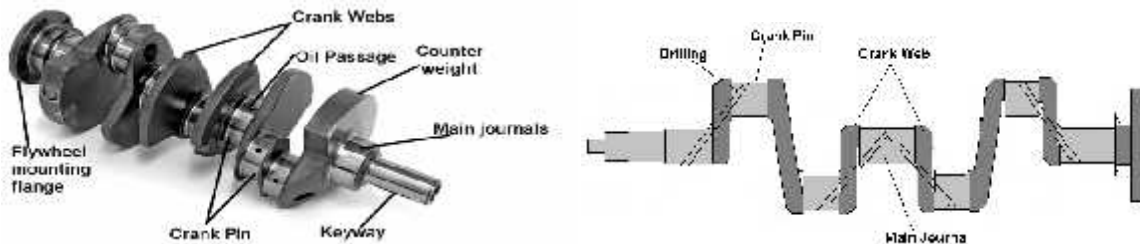

The parts of the crankshaft inside the main bearing are called main journals.

- Balancing weights are provided on the opposite side web for balancing. The crankshaft has drilled oil passages through which oil flow the main bearing to the connecting rod bearings.

The front end of the crankshaft carries three devices that

- A gear that drives the camshaft,
- The vibration damper to control torsional vibration, and
- The fan belt pulley. This pulley drives the engine fan, water pump, and generator with a V-belt.

The rear end of the crankshaft carries flywheel. The flywheel tends to keep the crankshaft running at constant.

Next, to the rear end, the main journal and oil seal is fitted. In some engine, oil return threads are provided which return the lubricating oil to the sump.

The crankshafts are generally of two types,

- In one piece type, all the parts are integral and are formed by drop forging and then machining.
- In build-up type, the crank pins and journals are fastened to the crank webs.

14. Cam Shaft

A camshaft is a shaft on which cams are mounted. A cam is a device that changes the rotary motion of the camshaft into the linear motion of the follower. A camshaft is responsible for the opening of the valves

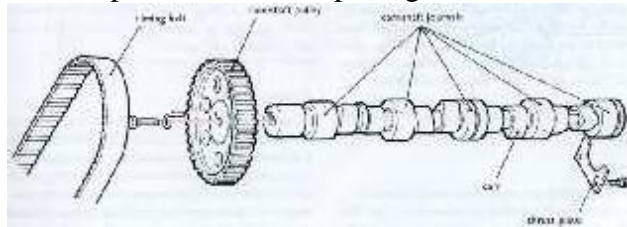

Construction:

- A camshaft has a number of cams along the length, two cams for each cylinder, one to operate the inlet valve and the other the exhaust valve.
- In addition, the camshaft has an eccentric to operate the fuel pump and gear to drive the ignition distributor and oil pump.
- The camshaft is driven by the crankshaft. The camshaft gear has twice as many teeth as the gear on the crankshaft.
- Camshaft made from forged alloy steel. This gives 1:2 gear ratio, the camshaft turns at half the speed of the crankshaft.

Working:

- Thus, every two revolutions of the crankshaft produce one revolution of the camshaft and one opening and closing of each valve, in the four-cylinder engine.
- Thus there is correct opening and closing of the valves takes in relation to the position of the piston in the cylinder.

There are three types of camshaft drive mechanism as follows,

- Gear drive.

- Chain drive.
- Belt drive.

15. Flywheel

The flywheel used in a transmission system of a vehicle.



Construction:

- A flywheel is a heavy steel wheel attached to the rear end of the crankshaft.
- The size of the flywheel depends upon the number of cylinders and the construction of the engine.

Working:

- During the power stroke the engine tends to speed up and during the other strokes, it tends to slow down.
- The inertia of the flywheel tends to keep the running of the crankshaft at a constant speed. Hence the engine speed is maintained constant.

16. Engine Valves

Engine valves are essential to control the timing of air-fuel mixture entry into the cylinder and combustion products out of the cylinders.



Construction:

- These are located at the inlet and outlet opening of the engine cylinder.
- The valves fit on the valve seats in their closed position.

There are three types of engine valves as follows,

1. Poppet valve
2. Sleeve valve
3. Rotary valve

16.1 Poppet valve

This is the most widely used valve in automobile engines. The poppet valve is given the name because of its motion of popping up and down. Its construction is very simple. This is also called a mushroom valve, because of its shape.

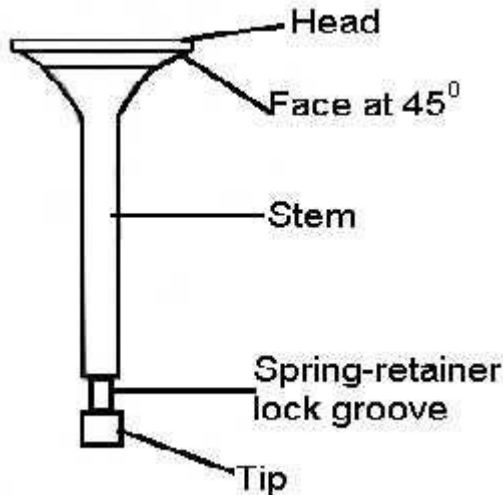

Construction:

- It consists of a head and a stem. The valve face usually with an angle of 30° to 45° is ground perfectly, since it has to match with the valve seat for perfect sealing.
- The stem has a spring retainer lock groove and the stem end is in contact with cam for up and down movements of the valve.

16.2 Sleeve Valve

The sleeve valve as the name implies, that it is a tube or sleeve kept between the cylinder wall and the piston.

Construction:

- The inner surface of the sleeve actually forms the inner cylinder barrel in which the piston slides.

The sleeve is in continuous motion and admits and drives out the gases by virtue of the periodic coincidence of port cut in the sleeve with ports formed through the main cylinder casting.

Advantages:

- Simple in construction.
- Sleeve valves are silent in operation.
- There is no noise because there are no noise making parts like valve cams, racker arm, tappets valves etc.,
- The tendency of detonation is less.
- Cooling is very effective as the valve is in contact with water jackets.

Disadvantages:

- High oil consumption for lubrication as a larger area of sleeve surface to be lubricated.
- Cleaning of the ports and the valve is complicated.

16.3 Rotary valve

The figure shows a simple sketch of a Rotary Valve. There are many types of rotary valves. The figure shows the disc type rotary valve. It consists of a rotating disc which has a port. While rotating, it communicates alternately with the inlet and exhaust manifolds.

Advantages:

- Rotary valves are simple in construction.
- These valves are manufactured at cheaper costs.
- They are suitable for high-speed engines.
- Stresses and vibrations are less compared to poppet and sleeve valves.
- They are smooth in operation and are uniform and noise-free operation.

Disadvantages:

- It is difficult in pressure sealing between the rotary disc and cylinder.
- Efficient valve lubrication is difficult.

Materials for valves:

- The materials used for inlet and exhaust valve are generally different because of the different operating conditions to which valves are subjected.
- Silico-chrome steel is the material generally used for inlet valves. For exhaust valves molybdenum as added to the silico-chrome.
- The recent materials for exhaust valve are austenite steel and precipitation hardening steel is generally used.

17. Governor

In petrol engines, the carburettor control both air and fuel supply to the engine cylinder under speed and load conditions. They vary the supply of air-fuel mixture to meet given condition. But in the diesel engine, the governor is used to keep the engine speed within limits.

- The main functions of a governor are to regulate the supply of fuel through some mechanism so that the engine speed remains within its range.

Working:

- On increased load, the engine speed decreases.
- When the load decreases, the engine speed increases.

Without a governor, the engine speed increases at lighter loads and the dynamic stresses damage the engine parts. The governor which is set for a particular engine speed operates a mechanism such that more fuel is injected to increase the engine power.

Governor, in this case, operates the mechanism to reduce the supply of fuel in the engine. It is essential to keep the engine speed within limits.

Types of Governor:

1. Mechanical Governor or Torque control Governor or Centrifugal governor.
2. Pneumatic Governor.
3. Hydraulic Governor.

Why not diesel engines are not preferred in commercial?

Timing Gears:

- Timing Gears These gears drive the camshaft from the crankshaft.
- Diesel engines, because they have much higher compression ratios (20:1 for a typical diesel vs. 8:1 for a typical gasoline engine), tend to be heavier than an equivalent gasoline engine.
- Diesel engines also tend to be more expensive.
- Diesel engines, because of the weight and compression ratio, tend to have lower maximum RPM ranges than gasoline engines. This makes diesel engines high torque rather than high horsepower, and that tends to make diesel cars slow in terms of acceleration.
- Diesel engines must be fuel injected, and in the past fuel injection was expensive and less reliable
- Diesel engines tend to produce more smoke.
- Diesel engines are harder to start in cold weather, and if they contain glow plugs, diesel engines can require you to wait before starting the engine so the glow plugs can heat up.
- Diesel engines are much noisier and tend to vibrate.
- Diesel fuel is less readily available than gasoline

Advantages diesel engines:

- The two things working in favor of diesel engines are better fuel economy and longer engine life. Both of these advantages mean that, over the life of the engine, you will tend to save money with a diesel.
- However, you also have to take the initial high cost of the engine into account. You have to own and operate a diesel engine for a fairly long time before the fuel economy overcomes the increased purchase price of the engine.
- The equation works great in a big diesel tractor-trailer rig that is running 400 miles every day, but it is not nearly so beneficial in a passenger car

7. TURBO CHARGER

A Turbocharger is a device that is used to increase the power of the engine or one can say efficiency of engine by increasing the amount of air entering into the combustion chamber. More air into the combustion chamber means more amount of fuel will be admitted into the cylinder and as a result one will get more power from the same engine if the turbocharger is installed in it.

TURBOCHARGER AND ITS WORKING

- Many people confuses between the TURBOCHARGER and SUPERCHARGER. The function of the supercharger is same as that of turbocharger but the supercharger is driven mechanically by the engine, often with the help of belt connected to the crankshaft, whereas turbocharger is powered by a turbine driven by the engine's exhaust gases.
- Turbocharger is considered more efficient than the superchargers as they are using the wasted energy of exhaust gases for its power source.

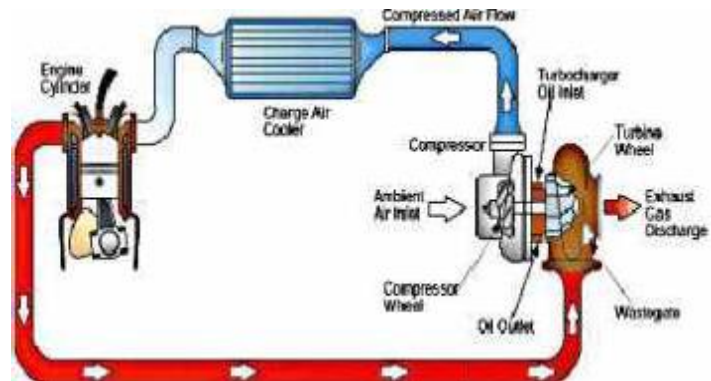
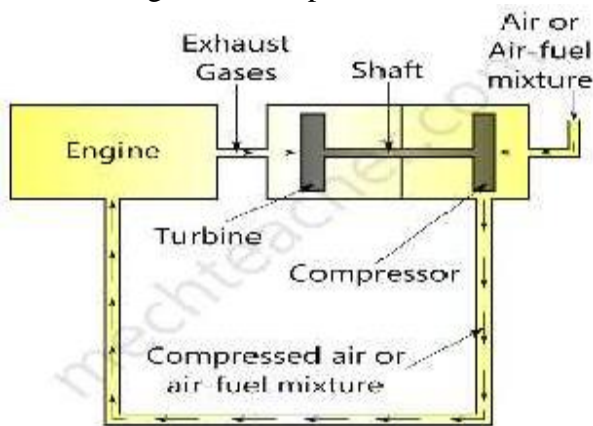

OPERATING PRINCIPLE OF TURBOCHARGER

- The amount of engine that actually goes into the engine's cylinder ,compared with the theoretical amount if the engine could maintain the atmospheric pressure ,is called volumetric efficiency and the aim of turbocharger is *to improve an engine's volumetric efficiency by increasing density of the intake gas.*
- The turbocharger's draws the air from atmosphere and compresses it with the help of centrifugal compressor before it enters into the intake manifold at increased pressure. This results in more amount of air entering into the cylinders on each intake stroke. *The centrifugal compressor gets power from the kinetic energy of engine's exhaust gases.*

The turbocharger has three main components

- *The turbine, which is almost a radial inflow turbine.*
- *The compressor which is almost a centrifugal compressor.*
- *The centre hub rotating assembly.*

WORKING OF THE TURBOCHARGER

- A turbocharger *mainly consists of two main sections: the turbine and the compressor. The turbine consists of turbine wheel and the turbine housing whose purpose is to guide the exhaust gases into the turbine wheel.*
- *The kinetic energy of the exhaust gases gets converted into the mechanical after striking it on turbine blades. The exhaust outlet helps the exhaust gases to get exit from the turbine.*

- *The compressor wheel in turbocharger is attached to a turbine with the help of steel shaft and as the turbine turns the compressor wheel, it draws the high-velocity, low pressure air stream and convert it into high-pressure, low –velocity air stream.*
- Cool air enters the engine's air intake and heads toward the compressor.
- The compressor fan helps to suck air in.
- The compressor squeezes and heats up the incoming air and blows it out again.
- Hot, compressed air from the compressor passes through the heat exchanger, which cools it down.
- Cooled, compressed air enters the cylinder's air intake. The extra oxygen helps to burn fuel in the cylinder at a faster rate.
- Since the cylinder burns more fuel, it produces energy more quickly and can send more power to the wheels via the piston, shafts, and gears.
- Waste gas from the cylinder exits through the exhaust outlet.
- The hot exhaust gases blowing past the turbine fan make it rotate at high speed.
- The spinning turbine is mounted on the same shaft as the compressor (shown here as a pale orange line). So, as the turbine spins, the compressor spins too.
- The exhaust gas leaves the vehicle, wasting less energy than it would otherwise.

Benefits of using a turbocharger

- Turbocharger increases the volumetric efficiency of the engine.
- It increases the output power produced.
- It reduces the intake of fuel or air-fuel mixture.
- It allows the engine to work smoothly in various ambient conditions.
- The kinetic energy of exhaust gases is fed back to the engine and used beneficially.

8. SUPER CHARGER

- The purpose of the supercharger is to create extra power in the car engine while it is connected to it. The supercharger is a large pump that compresses and forces air into the engine to increase the horsepower of the vehicle. Car racers use superchargers in their vehicles during races for faster and better performance.
- It is an affordable and reliable choice for creating extra horsepower. Though there are many expensive cars available with engines with more horsepower, the use of supercharging is proven to be a cheaper and affordable choice.

The Working of Supercharger

- When an engine is started, supercharger forces air into the cylinders increasing per minute rotations of the cranks. As rotations increases and the crank begin to spin faster, more air is pushed into the impellers of supercharger creating more power in the engine.
- This results in complete and efficient combustion of fuel. The mounting of superchargers increases the performance of the engine more boost being created every time air is forced by the supercharger.
- Goat Performance Products have some of the best and high-class superchargers, which can provide a boost to the engine and make your vehicles behave nothing less than a supercharged commodore.

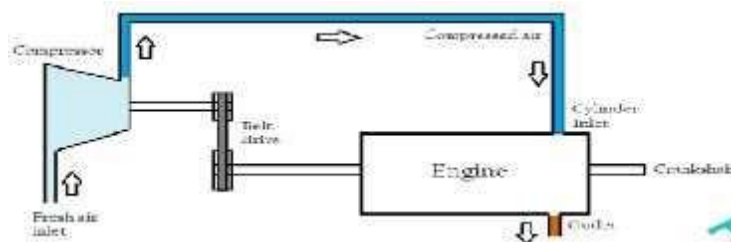

Advantages of supercharging:-

- Higher power output. This was whole point of studying & installing superchargers.
- Reduced smoke from exhaust gases. The extra air pushed into cylinder, helps the air to complete combust leading to lesser smoke generation.
- Quicker acceleration of vehicle. Supercharger starts working as soon as the engine starts running. This way the engine gets a boost even at the beginning leading to quicker acceleration.
- Cheaper than turbocharger.

Limitations:-

- Draws power from engine. Though the overall mechanical efficiency is increased but it consumes power from the engine. The same job is done by a turbocharger without consuming extra power !
- Increased heat generation. The engine should have proper heat dissipation systems as well as it should be able to withstand thermal stresses !
- Induces stress. The engine must hold up against the high pressure & bigger explosions generated in the cylinder. If the engine is not designed considering these stresses, it may damage the piston head.

SUPERCHARGERS	TURBOCHARGERS
Superchargers are basically	Turbos are devices consisting both- turbine & a
Extra power is to be supplied.	Doesn't need extra power.
They draw power from engine.	They extract their power from the exhaust gases.
They are connected to the intake	Since they are a combination of turbine & a
Suitable for engines with smaller	Suitable for engines with higher displacements.
Superchargers start working as	Turbos won't start operating until sufficient amount of
Less efficient, since it demands	More efficient, as it draws it's power from the exhaust
Superchargers cost less.	Turbos are costly.
Easy maintenance.	Difficult to maintain, since lot of heat gets generated &
No lag, Power delivery is	Turbo takes time to spin up to speed. Hence, there's a
Greater acceleration could be	Higher speeds could be achieved.

9. EXPLAIN THE FOLLOWING FILTERS BRIEFLY.

(I) AIR FILTER

(II) OIL FILTER

(III) FUEL FILTER

AIR FILTER

- As the air filter is Heart of any Engine Assembly so air filter reduces maximum amount of unwanted air particulates. Which helps to increase the performance of an engine?
- A particulate air filter is a device composed of fibrous materials which removes solid particulates such as dust, mold, and bacteria from the air. A chemical air filter consists of an absorbant or catalyst for the removal of airborne molecular contaminants such as volatile organic compounds or ozone.
- Air filters are used in applications where air quality is important, in building ventilation systems and in engines.



Need for air filter

- A particulate air filter is a device composed of fibrous materials which removes solid particulates such as dust, mold, and bacteria from the air.
- A chemical air filter consists of an absorbant or catalyst for the removal of airborne molecular contaminants such as volatile organic compounds or ozone.
- Air filters are used in applications where air quality is important, in building ventilation systems and in engines.

History

- First Air filter founded by "Norm McDonald" In 1869 which is used in first "Ford Engine"



RAW MATERIALS

- Rubber
- Polypropylene material
- Wood
- Steel

Manufacturing Process

- Paper rolling
- Punching
- Squeezing
- Molding & Pouring rubber
- Painting with Paper Assembly
- Spraying Lubricant
- Finishing

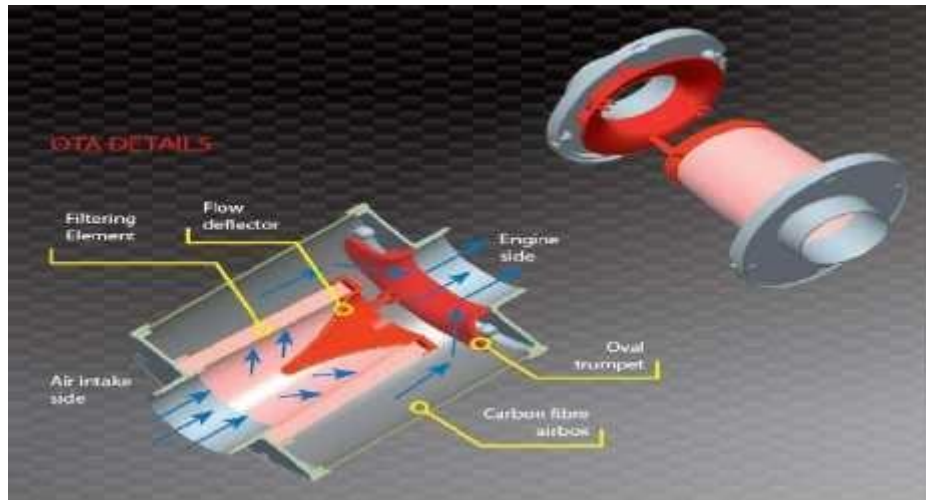

Types of Air filters

- Flat Filters.
- Round Filters.
- Oil Impregnated Filters.
- Conical Shaped

Advantages

- Maximum Efficiency
- Supply of turbulent & Clean Air
- Avoid Piston & cylinder wear
- Increase fuel efficiency
- Maximum Performance in less fuel Consumption
- Act as Cylinder
- Reduces other Maintainance
- A normal car engine uses about 100-200 Cu of air a minute , and a filter is essential to prevent particles of dust or dirt, blocking air jet.

OIL FILTER

- removes most of the impurities that have been picked up by the oil as it is circulated through the engine
- The filter is mounted outside the engine and is designed to be readily replaceable

Two basic filter element configurations

- the cartridge-type
- the sealed can-type

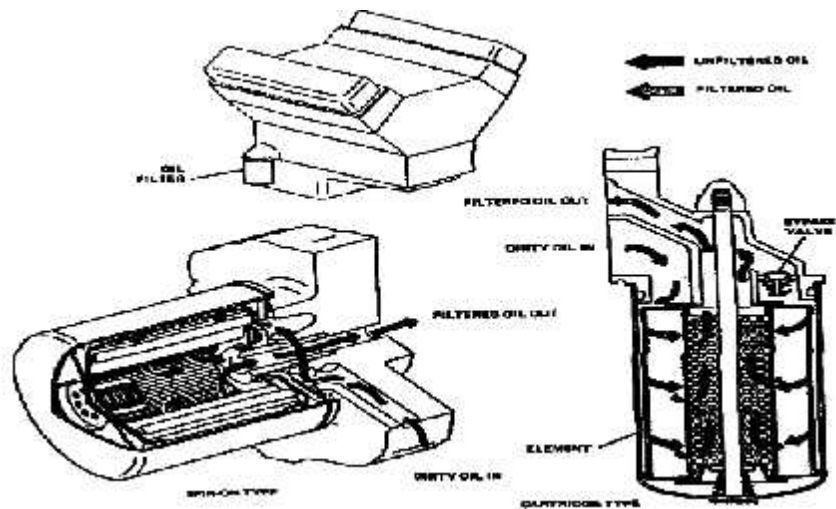

Cartridge-type filter element fits into a permanent metal container

- The element is changed easily by removing the cover from the container when this type of filter is used
- Sealed cam-type filter element is completely self-contained, consisting of an integral metal container and filter element.
- This type of filter is screwed onto its base and is removed by spinning it off Filter Medium Materials
- most popular automotive filter mediums
 - ❖ Cotton waste
 - ❖ resin-treated paper
- They are held in place by sandwiching them between two perforated metal sheets
 - ❖ layers of metal that are thinly spaced apart for heavy-duty applications

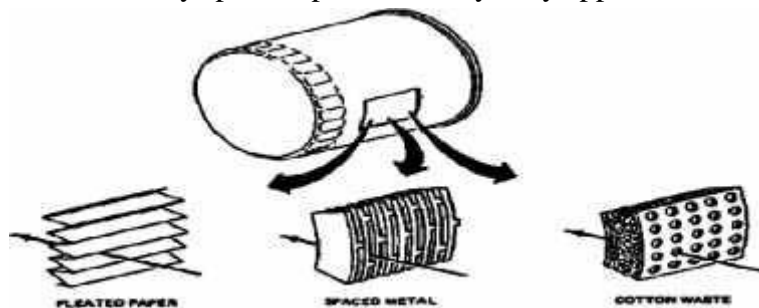

Filter System Configurations.

Two-filter system configurations

- The full-flow system
- Bypass system. Operation

Full-flow system

- The most popular in current automotive design
- All oil in a full-flow system is circulated through the filter before it reaches the engine
- It incorporate a bypass valve in the oil filter to allow the oil to pass through the element in the event it becomes clogged. This will prevent the oil supply from being cut off to the engine.

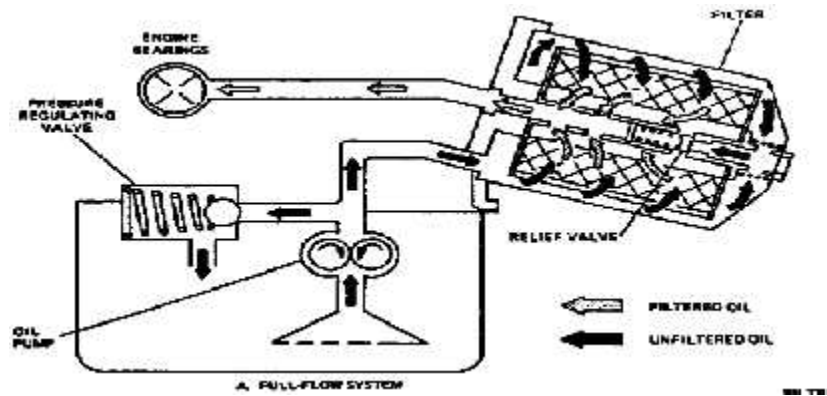

Bypass system

- Diverts only a small quantity of the oil each time it is circulated and returns it directly to the oil pan after it is filtered.

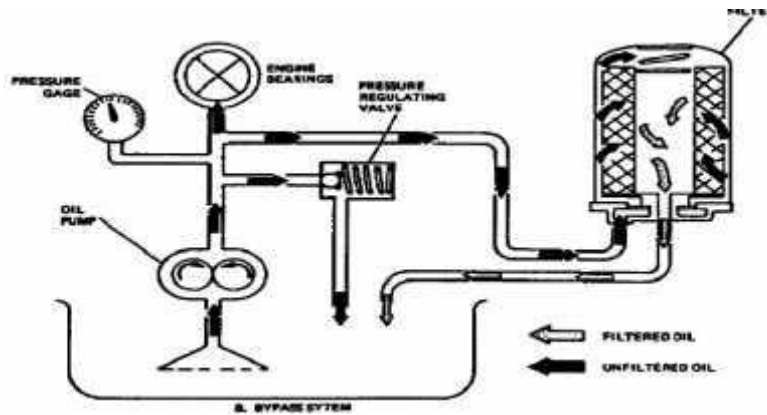

FUEL FILTER

- A fuel filter is a filter in the fuel line that screens out dirt and rust particles from the fuel. They are normally made into cartridges containing a filter paper. They are found in most internal combustion engines
- Fuel filters serve a vital function in today's modern, tight-tolerance engine fuel systems. Unfiltered fuel may contain several kinds of contamination, for example paint chips and dirt that has been knocked into the tank while filling, or rust caused by moisture in a steel tank. If these substances are not removed before the fuel enters the system



10. EXPLAIN THE CLASSIFICATION OF IC ENGINES.

Classification of IC Engines:

The classification of IC Engines is as follows.

1. Number of Strokes
2. Type of Ignition
3. Basic Engine Design
4. Working Cycle
5. Fuel used
6. Method of Fuel Supply
7. Method of Cooling
8. Cylinder Arrangement
9. Engine Speed
10. Method of Charging
11. Lubrication
12. Applications

Detailed classification of IC Engines:

The Detailed classification of IC Engines was presented below.

1. NUMBER OF STROKES:

FOUR STROKE ENGINES

The four strokes of a 4 stroke engine go by the name –

Suction/Intake Stroke :-

- In this stroke, the piston moves from TDC to BDC [(Top Dead Centre – the farthest position of piston to the crankshaft) to (Bottom Dead Centre – the nearest position of piston to the crankshaft)].
- The piston moves downward sucking the air-fuel mixture from the intake valve.

Key points :-

Intake valve – OPEN

Exhaust valve – CLOSED

Crankshaft rotation – 180°

Compression Stroke :-

- Here, the piston moves from BDC to TDC compressing the air-fuel mixture. The momentum of flywheel helps the piston to move upwards.

Key points :-

Intake valve – CLOSED

Exhaust valve – CLOSED

Crankshaft rotation – 180° (total = 360°)

Power Stroke :-

- The second rotation of crankshaft has begun as it completes one full rotation during compression stroke. Power stroke begins with the expansion of air-fuel mixture ignited with the help of spark plug. Here, the piston moves from TDC to BDC. This stroke produces mechanical work to rotate the crankshaft.

Key points :-

Intake valve – CLOSED

Exhaust valve – CLOSED

Crankshaft rotation – 180° (total = 540°)

Exhaust Stroke :-

- Again the momentum of flywheel moves the piston up from BDC to TDC thereby driving the exhaust gases outside through the exhaust valve.

Key points :-

Intake valve – CLOSED

Exhaust valve – OPEN
 Crankshaft rotation – 180°(total = 720°)

FOUR STROKE CYCLE ENGINE

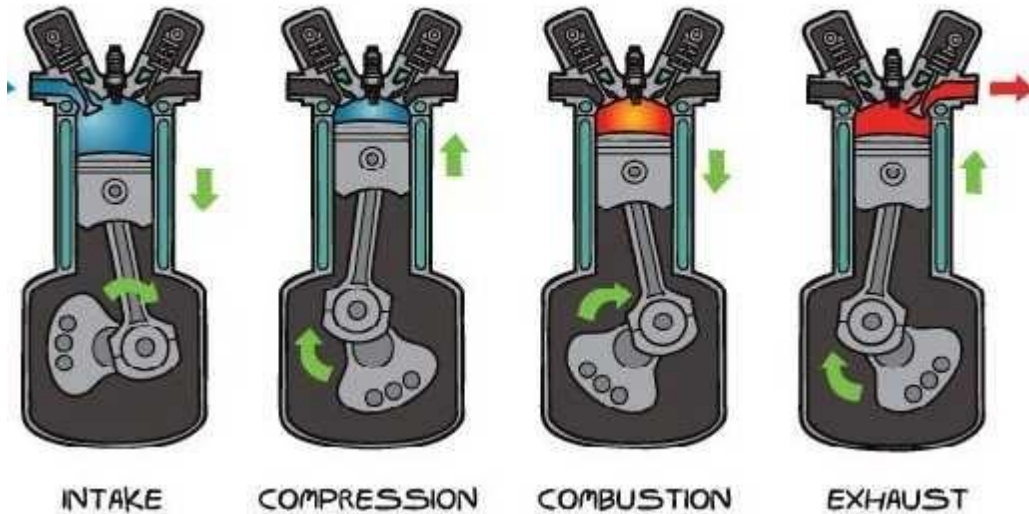

TWO STROKE ENGINES

Working of 2 stroke engine :-

Downward Stroke :-

- First the piston is moved downside from TDC to BDC to let the fresh air enter into the combustion chamber. The fresh air-fuel mixture gets into the combustion chamber through crankcase. Crankshaft rotation – 180°

Upward Stroke :-

- Here happens all the magic. The piston is pushed up from BDC to TDC. The fuel-air mixture gets compressed & spark plug ignites the mixture. As the mixture gets expanded, the piston moves down. During up stroke, the inlet port is opened. While this inlet port is opened, the mixture gets sucked inside the crankcase. When the mixture is pushed up into the combustion chamber during the previous up stroke, a partial vacuum is created as no mixture is left behind in the crankcase. This mixture is ready to go into the combustion chamber during down stroke but remains in the crankcase until the piston goes up till TDC. Crankshaft rotation – 360°

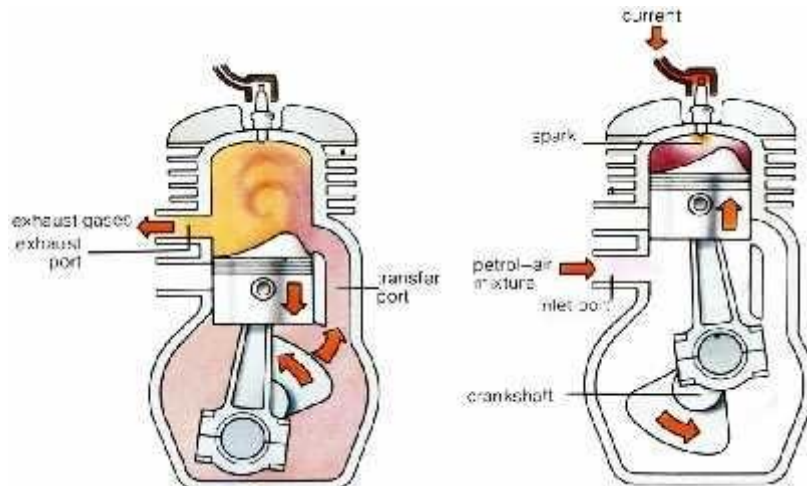

2. BASED ON TYPE OF IGNITION

- Spark Ignition Engines: Spark Is Generated through an External Source
- Compression Ignition Engines: Air Is Heated to a Sufficiently High Temperature Because of High Compression Ratio

Classification of IC engines based on type of ignition

Battery Ignition system

In a battery ignition system a battery is used to provide energy for ignition. It is work as storage of energy and charged by dynamo, which is driven by engine. It converts chemical energy to electric energy.

Two types of battery used in spark ignition system, lead acid battery and alkaline battery. The first one is used in light duty commercial vehicle and the other one is used in heavy duty commercial vehicle. It is housed in primary side of ignition coil.

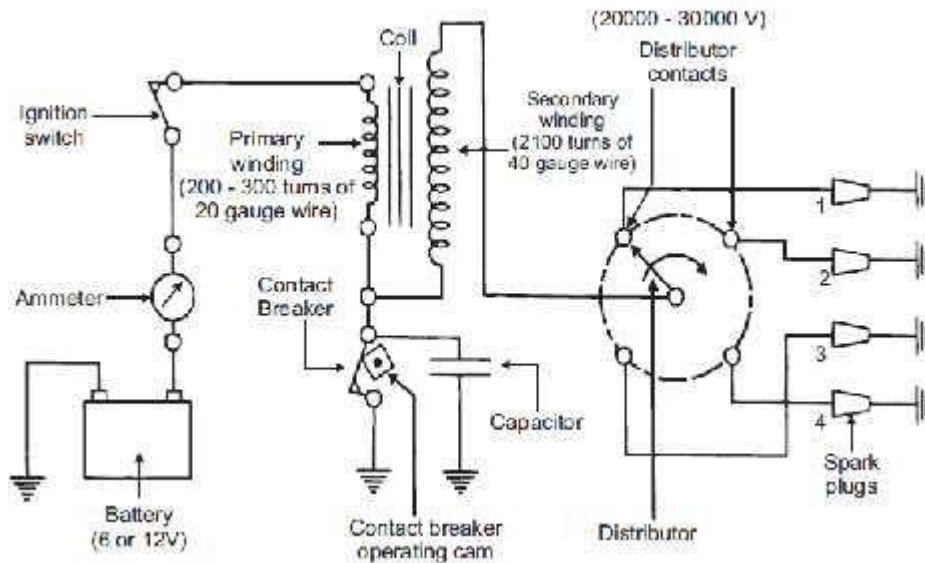

Magneto Ignition system

A magneto is a small electric generator which is rotate by the engine and is capable of produce a very high voltage and does not need battery as a source of external energy.

The magneto contains both primary and secondary winding thus it does not require a separate coil to boost up the voltage required to operate the spark plug.

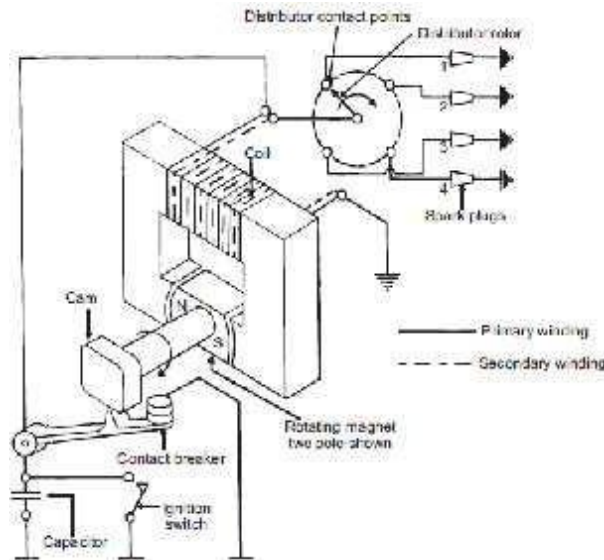

Electronic Ignition system

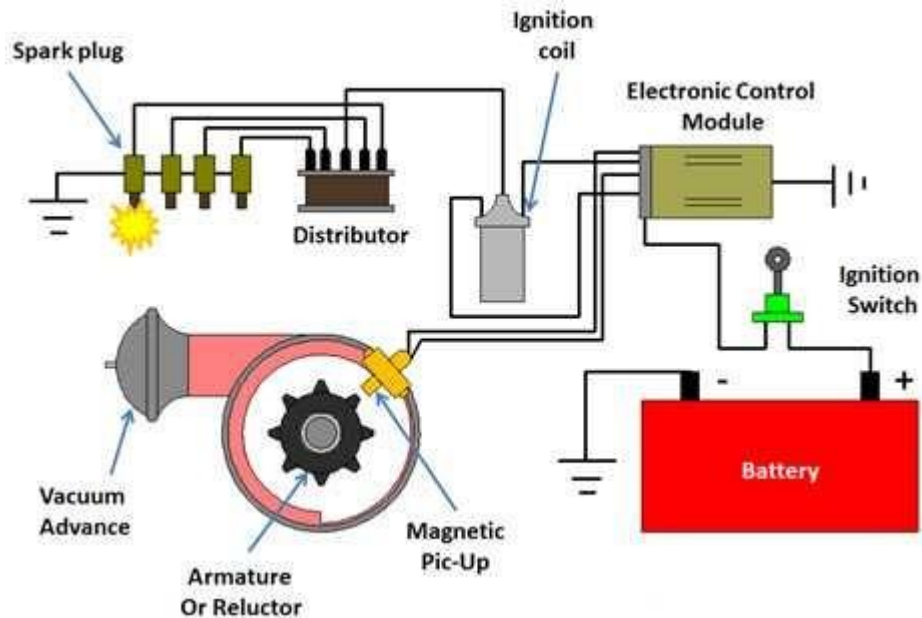

- Electronic ignition system is the type of ignition system that uses electronic circuit, usually by transistors controlled by sensors to generate electronic pulses which in turn generate. Better spark that can even burn the lean mixture and provide better economy & lower emission.

3. Basic Engine Design:

- Reciprocating Engines
- Rotary Engines (Wankel Engine)

4. Working Cycle:

- Engines working on OTTO Cycle (SI Engines)
- Engines working on DIESEL Cycle (CI Engines)

5. Fuel used :

- Gasoline or Petrol Engines
- Compressed Natural Gas (CNG) Engines
- Diesel Engines

6. Fuel Supply:

- Carbureted type- Fuel supplied through Carburetor
- Injection type- Fuel supplied through injector. Fuel injected into the cylinder just before Ignition.

7. Method of Cooling

- Cooling Is Essential for the Satisfactory and Healthy Working Of the Engine (Otherwise Results In Engine Seizing)

➤ *Two Types of Engine Cooling In Practice*

Classification of IC engine based on type of cooling

1. Air cooled engines

Air-cooled engines rely on the circulation of air directly over hot parts of the engine to cool them

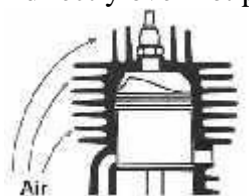

2. Water cooled engines

Water cooling is a method of heat removal from components and industrial equipment. As opposed to air cooling, water is used as the heat conductor. Water cooling is commonly used for cooling internal combustion engines.

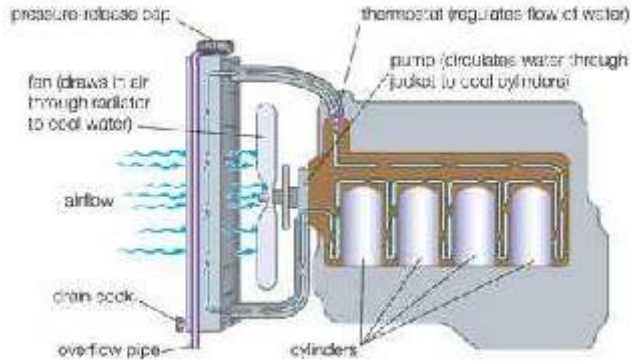

Nature water cooled system (forced circulation)

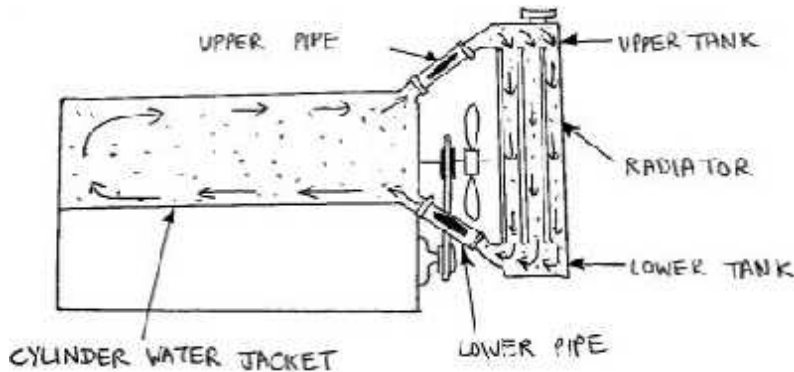

Thermosiphon water cooled system

8. Type Of Cylinder Arrangements

- V- Engine
- Opposed Cylinder Engine
- Opposed Piston Engine
- Radial Engine
- X-type Engine
- H-type Engine

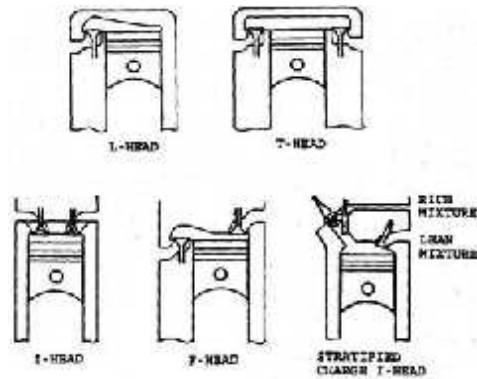

9. Classification Based On Engine Speed

- Low Speed – up to 500 rpm
- Medium Speed – 500 to 1000 rpm
- High Speed – above 1000 rpm

10. Classification Based On Method of Charging

Classification of IC engines based on method of charging

Naturally aspirated engines

A naturally aspirated engine is an internal combustion engine in which oxygen intake depends solely on atmospheric pressure and does not rely on forced induction through a turbocharger or a supercharger. Many sports cars specifically use naturally aspirated engines to avoid turbo lag.

Supercharged engines

A supercharger is an air compressor that increases the pressure or density of air supplied to an internal combustion engine. This gives each intake cycle of the engine more oxygen, letting it burn more fuel and do more work, thus increasing power.

Classification Based On lubrication system

The various lubrication systems used for lubricating the various parts of engine are classified as

1. Mist lubrication system
2. Wet sump lubrication system, and
3. Dry sump lubrication system.

Mist lubrication system:

Mist lubrication system is a very simple type of lubrication. In this system, the small quantity of lubricating oil (usually 2 to 3%) is mixed with the fuel (preferably gasoline). The oil and fuel mixture is introduced through the carburetor. The gasoline vaporized and oil in the form of mist enters the cylinder via the crank base. The droplets of oil strike the crank base. The droplets of oil strike the crank base, lubricate the main and connecting rod bearings and the rest of the oil lubricates the piston, piston rings and cylinder.

The system is preferred in two stroke engines where crank base lubrication is not required. In a two-stroke engine, the charge is partially compressed in a crank base, so it is not possible to have the oil in the crank base. This system is simple, low cost and maintenance free because it does not require any oil pump, filter, etc. However, it has certain serious disadvantages. Therefore, it is not popular among the lubrication system. Its disadvantages are the following:

1. During combustion in the engine, some lubricating oil also burnt and it causes heavy exhaust and forms deposits on the piston crown, exhaust port and exhaust system.
2. Since the lubricating oil comes in contact with acidic vapours produced during the combustion, it gets contaminated and may result in the corrosion of the bearings surface.
3. When the vehicle is moving downhill, the throttle is almost closed, and the engine suffers lack of lubrication as supply of fuel is less. It is a very serious drawback of this system.
4. There is no control over the supply of lubricating oil to the engine. In normal operating conditions, the two-stroke engines are always over-oiled. Thus consumption of oil is also more.
5. This system requires thorough mixing of oil and fuel prior to admission into the engine. It requires either separate mixing or use of some additives.

Wet-sump lubrication system:

In the wet-sump lubrication system, the bottom of the crank case contains an oil pan or sump that serves as oil supply, oil storage tank and oil cooler. The oil dripping from the cylinders, bearings and other parts, fall under gravity back into the sump, from where it is picked up by pump and recirculated through the engine lubrication system. There are three varieties in wet-sump lubrication system. They are:

1. Splash lubrication system
2. Splash and pressure system and

3. Pressurized lubrication system.

Splash lubrication System:

Splash lubrication system is used on small, stationary four-stroke engines. In this system, the cap of the big end bearing on the connecting rod is provided with a scoop which strikes and dips into the oil-filled trough at every revolution of the crank shaft and oil is splashed all over the interior of crank case into the piston and over the exposed portion of the cylinder is shown in the figure below.

A hole is drilled through the connecting rod cap through which the oil passes to the bearing surface. Oil pockets are provided to catch the splashed oil over all the main bearings and also the cam shaft bearings. From these pockets oil passes to the bearings through drilled hole. The surplus oil dripping from the cylinder flows back to the oil sump in the crank case.

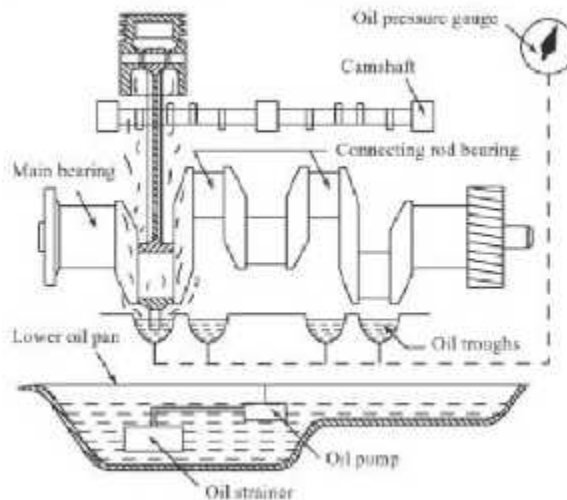

Splash and pressure lubrication system:

Splash and pressure lubrication system is combination of splash and pressure system as shown in below figure. In this system, the lubricating oil is supplied by a pump under pressure to main and cam shaft bearings. the oil is also directed in the form of spray from nozzle or splashed by a scoop or dipper on the big end to lubricate bearings at the big end of the connecting rod, crank pin, gudgeon pin, piston rings and cylinder.

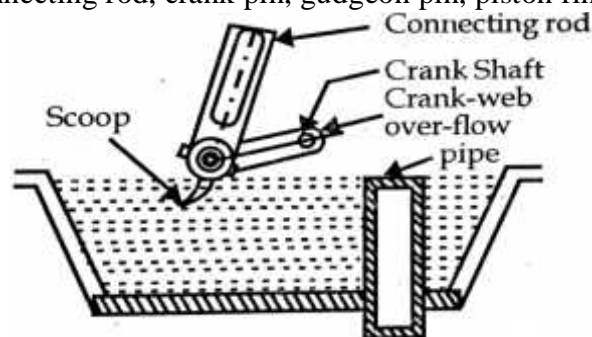

Pressurized lubrication system:

In pressurized lubrication system, the lubricating oil is supplied by a pump under pressure to all parts requiring lubrication as shown in below figure. The oil under the pressure is supplied to main bearings of the crank shaft and camshaft. Holes drilled through the main crank shaft bearings journals, communicate oil to big end bearing and small end bearings through the hole drilled in the connecting rod. a pressure gauge is provided to confirm the circulation of oil to various parts.

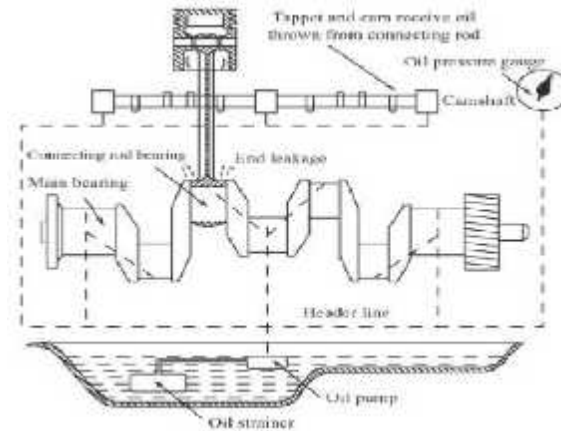

This system provides sufficient lubrication to all parts and is favoured by most of the engine manufacturers. This is used in most heavy duty and high-speed engines.

Dry-sump lubrication system:

In dry-sump lubrication system, the oil supply is carried from an external tank. The oil from the sump is pumped by means of a scavenging pump through filters to the external storage tank. The oil from the storage tank is pumped to engine cylinder through and oil cooler. The oil pressure may vary from 3 to 8 bar.

The dry-sump lubrication system is generally used for heavy-duty engines.

12. Classification Based On Applications:

- Motor cycle engine
- Automobiles
- Earth Movers
- Locomotive engine
- Marine engine
- Aero engine
- Prime movers for Electric Generator

1. EXPLAIN THE SINGLE PLATE CLUTCH WITH NEAT SKETCH.

- Clutch is mechanical device which is used to transmit rotating motion or torque from one shaft to another shaft when required.
- Clutch provides a temporary connection between input and output shaft. Clutch lies between the engine and the gear box.
- We can easily connect and disconnect the power transmission from one shaft to another by means of clutch as we do in automobiles while changing gear we press clutch lever to disengage the shafts and after change the gear we again release lever for engagement. Depending upon the number of friction contact surfaces the friction clutches as single or multi plate clutches. Here we study about single plate clutch.
- It is a type of friction clutch in which power is transmitted by means of friction between the contact surface usually called clutch plates.
- As name suggest a clutch consists of only one clutch plate with both side friction lining (frictional surface). These surfaces have high Coefficient of friction. Single plate clutch also called dry clutch because no lubricant is used as coolant.

Construction:

- A single plate clutch is consisting of various parts; for proper working. They are arranged in a systematical order. Mainly it consists of a clutch plate with both side friction lining and some other parts which helps in the proper functioning of a clutch like flywheel, pressure plate, thrust bearing, hub, springs and input mechanism for engaging and disengaging of clutch.
- Clutch plate is attached with the hub between flywheel and the pressure plate, it moves axially on driven shaft. In single plate clutch; clutch plate should have both side friction lining because it is mounted between pressure plate and flywheel, friction is responsible for the torque transmission.
- The pressure plate is attached with the flywheel and springs. Pressure plate helps to push the clutch plate towards the flywheel. A lever is attached to thrust bearings with some mechanism on driven shaft which transmits input and output motion from clutch pedal.
- We can divide different parts of single plate clutch as driving side parts and driven side parts. Clutch plate is junction between the both sides. In driving side flywheel is attached to engine and driven members are pressure plate, springs, thrust bearings and liver etc.

Following are the different parts used in single plate clutch:



Clutch plate:

- In single plate clutch only one clutch plate is used. Clutch plate is main component of clutches. It is thin disc type metallic plate having both side frictional surfaces. Frictional surfaces on plate must be of such material to provide friction for transmitting torque without slipping. The coefficient of friction of contact surfaces should be high for proper connection without slipping. Clutch plate is assembled in between flywheel and pressure plate.

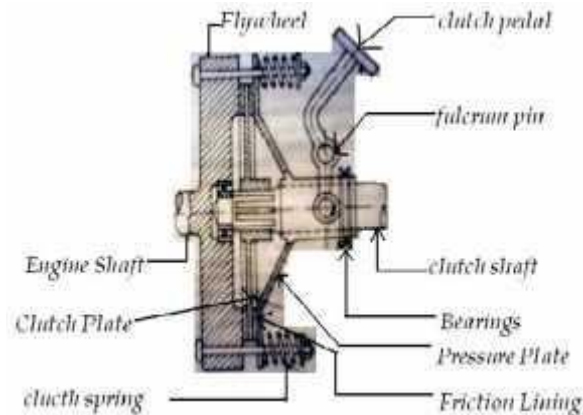

Pressure plate:

- The pressure plate which is generally made up of cast iron. It helps in applying pressure on clutch plates to maintain the proper contact between the surfaces of flywheel and clutch plate by means of spring which are attached to it.

Springs:

- Springs are used to maintain the pressure on pressure plate for proper connection between clutch plate and flywheel and prevent the slipping of contact surfaces.

Flywheel:

- Flywheel is attached to engine output and its other side comes in contact with clutch plate when pressure is applied by the pressure plate.

Operating mechanism:

- This includes foot pedal, linkage, bearing and lever etc. All these components are connected in a sequence. Foot pedal is located inside the automobiles; a lever mechanism is attached with foot pedal which transmit the motion from pedal to spring by means of thrust bearings.

Working:

- Working of single plate clutch is very simple. A mechanism is responsible for the engagement and disengagement of clutch. We easily engage and disengage the torque transmitting shafts just by apply some force on the paddle of automobile.
- A lever is attached to the paddle which is responsible for the force transmission from the paddle. When pedal is pressed spring is compressed and engine is free to move without any load. Lever is attached in such a manner when we press the clutch paddle thrust bearing moves forward and pressure plate moves backward or it moves away from the flywheel; due to this the connection between the clutch plate and flywheel released and shafts are disengaged. This time we can easily change gears in case of automobiles. Again if we want to engage the shafts just release the clutch paddle; then springs attached to the pressure plate push the pressure plate forward.

- Clutch plate is mounted between the pressure plate and flywheel on the hub. Clutch plate has both side friction lining that's why it mounted in between pressure plate and flywheel and helps in torque transmission.

Advantages:

- The working of the single plate clutch is smooth i.e. the engagement and disengagement is very smooth in operation
- Less slip occurs in it; slip is occurs only at the time of engagement after engagement no slip occurs and the functioning becomes very smooth.
- Power losses are very less.
- Less heat generates because only single plate is used. Heat generation creates problem in power transmission and can damage the working parts.
- Sometimes it works as a safety device and prevent the damage in running parts if input torque/ power exceed the required torque then slip occurs between the clutch plate and contact surface because it works on a specific range of torque.
- Single plate clutches have quick operation and respond fast.
- No requirement of coolant because less is generated therefore they are called dry clutches.

Disadvantages:

- It has less torque transmitting capacity
- It has bigger in size even for transmitting less torque.
- It requires high maintenance because they are dry clutches and it is necessary to prevent them from moisture or any leakage of lubricant/oil in machinery.
- Single plate clutches have high wear and tear rate and have less smooth engagement.

Applications:

- These are used in large size automobiles where radial space is not constrain such as trucks and cars.
- This is all about single plate clutch working and its parts. If you have any query regarding this article, ask by commenting. If you like this article, don't forget to share it on social networks. Subscribe our website for more informative articles. Thanks for reading it.

1. EXPLAIN THE MULTI-PLATE CLUTCH WITH NEAT SKETCH.

- From 2 wheeler like bike to 4 wheeler like cars we often hear the term "Clutch" whenever we talk about gears or gear shifting in an automobile, as we know to shift the drive from high torque to high speed or vice versa we need to press the clutch pedal than only the gear shift becomes possible but the question arise what does this clutch do? Why it is so important part of an automobile vehicle? The basic answer is "A clutch is a device that is used to transmit fluctuating rotation between 2 shafts" but how it is done? Still remains unanswered let's find out the answer by discussing the Multi-plate clutch, A type of clutch used in many vintage cars and in bikes.
- A multi-plate clutch is a type of clutch in which the multiple clutch plates are used to make frictional contact with the flywheel of the engine in order to transmit power between the engine shaft and the transmission shaft of an automobile vehicle.
- A multi-plate clutch is used in automobiles and in machinery where high torque output is required.
- In bikes and scooter multi-plate clutch is used due to the limitation of compact gearbox used in bikes and scooter.

What is the Need of a Multi-Plate Clutch?

- As we know a clutch is the most important integral part of a power train as it is used to transmit the power from engine shaft to the transmission shaft for further shifting the drive to required torque or speed output.
- Where there is a need of high torque output like in pick-up truck, a single plate clutch fails to provide that much frictional force (between flywheel and clutch plates) that is required to provide such a high torque, so in heavy vehicle like pickup trucks multi-plate clutches are used.

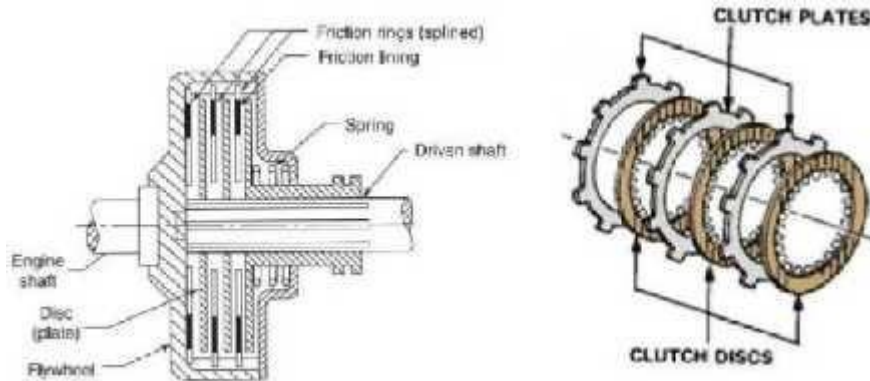

Main Parts of the Multi Plate Clutch

- The main components of all the clutches used in automobile vehicle are almost same but with some modifications, so let's discuss the main parts of different types of multi-plate clutches used.

Spring Type Multi-Plate Clutch

1. Pressure Plate

- A plate attached to the splined sleeves which are further attached to the pedal fulcrum such that when the clutch pedal is pressed, the sleeves attached to the pedal fulcrum moves outward which in turn moves the pressure plate attached with this splined sleeve.
- This pressure plate used in clutch applies pressure over the clutch plates with the help of thrust springs that helps the pressure plate to maintain its frictional contact with the clutch plates.

2. Clutch Plate

- The inner frictional surface of the clutch plate makes contact with the flywheel and the outer frictional surface makes frictional contact with the pressure plate whose movement is operated by the clutch pedal.
- In multi-plate clutch multiple clutch plates are used in which number of clutch plates are placed over each other which in turn increases the frictional force required for engagement of the clutch.

3. Thrust Springs

- These are the springs used behind the pressure plate and the stiffness of these springs is used by the pressure plate to maintain the frictional contact with the clutch plates which in turn maintain the clutch engagement.
- Numbers of thrust springs are placed over the outer surface of the pressure plate in circular fashion.
- The force applied by the driver over the clutch pedal is transferred to these thrust springs which in turn causes movement of these springs and the disengagement of the clutch occurs.

4. Clutch Pedal

- A clutch pedal operated by the driver of the vehicle is used to control the engagement and disengagement of the clutch.
- When the clutch pedal is pressed the fulcrum attached with its inner end rotates which in turn causes movement in the splined sleeves through which the pressure plate attached and with this movement of splined sleeve disengagement of the clutch occurs.

5. Splined Shaft & Inner Splined Sleeves

- A outer splined transmission input shaft is used over which the complete clutch assembly that includes clutch plates, pressure plate , inner splined sleeve , clutch casing is placed and rotates with it .
- The inner splined sleeve which is attached to the pressure plate in multi-plate clutch, The movement of this sleeve is controlled by the clutch pedal.
- The to and fro movement of this inner splined sleeve causes engagement and disengagement of the clutch.

6. Flywheel

- Though this is the part of the engine but we can also consider it as a part of clutch system as the transmission of power from engine output shaft to the transmission shaft is obtained by the frictional contact between the clutch and the flywheel of the engine.

Diaphragm Clutch

- All the parts of the diaphragm clutch and the spring type clutch is same but the modification is made in the spring used for engagement and disengagement of the clutch. Let's discuss about it.

1. Diaphragm Spring

- In diaphragm type clutch system the thrust springs used in spring type clutch is replaced with a special diaphragm type springs.
- This diaphragm spring is a circular spring having number of fingers like fins at its central surface which looks like a inflated diaphragm.
- During engagement these finger like fins of the diaphragm spring remains in the inflated shape which in turn applies pressure over the pressure plate and maintain the friction contact between the pressure plate, clutch plates, and flywheel respectively.
- When the clutch pedal is pressed these finger like fins of the diaphragm spring moves just like a deflated diaphragm which in turn removes the pressure over the pressure plate and disengagement of the clutch occur.

Hydraulic or Automatic Multi-plate Clutch

- All the component of the hydraulic type multi-plate clutch is almost same as the diaphragm clutch but the modification is made in its operation that is.
- In this type of clutch the engagement and disengagement of the clutch is controlled by the hydraulic device (eg- torque converter) controlled with the accelerator pedal and is coupled with the diaphragm type multi-plate clutch.
- No clutch pedal is required in this type of multi-plate clutch.

Working

- The working of the multi-plate clutch can be best understood by discussing the simple spring type multi-plate clutch

Engagement of Clutch

- During the engaged state of the clutch i.e. when the clutch pedal is not pressed, The thrust springs do not move due to which the stiffness provided by these springs maintains the pressure over the pressure plate having friction lines on its inner surface.
- Due to this pressure over the pressure surface the frictional contact between the friction lines of pressure plate and the friction lines of multiple clutch plates is maintained due to which frictional force is applied over the flywheel.
- Due to this frictional force the frictional contact between the multiple clutch plates and the flywheel is maintained which in turn finally provides clutch engagement.

Disengagement of Clutch

- When the clutch pedal is pressed the fulcrum attached at its inner end rotates due which the inner splined sleeve through which the pressure plate is attached moves outward which in turn applies pressure over the thrust springs.
- Due to this force the thrust springs moves which in turn release pressure over the pressure plate and finally the frictional force between pressure plate, clutch plate and the flywheel is removed.
- Due to this removal of the frictional force, frictional contact between the pressure plate, clutch plate and flywheel breaks and finally the disengagement of the clutch is obtained.
- In diaphragm type multi-plate clutch all the working is almost same the little difference is that instead of thrust springs, diaphragm spring is used for engagement and dis engagement of the clutch.
- In automatic type multi-plate clutch the working differs as the operation of engagement and disengagement of the clutch is made automatic through the hydraulic device operated with the accelerator pedal which is coupled with the diaphragm type multi-plate clutch.

Advantages

- Increased torque transmission capacity.
- Highly reliable.
- Suitable for heavy vehicles.

2. EXPLAIN THE CONE CLUTCH WITH NEAT SKETCH.

- The development of a family starts with a old grandfather” very rightly said as with the introduction of the transmission in an automobile vehicle, development of a device that can transfer fluctuating power (rotational motion) between 2 shafts became essential due to which various researches had been done and finally the engineering minds of that era came up with a system which is known as Clutch or more specifically a Cone clutch.
- The modern clutches we use today in vehicle are the progeny (descendent) of the cone clutch. The continuous modification in this field has led us to the development of the modern automatic clutch which is the boom in the automobile industry. So let’s know more about the great grandfather of the clutches i.e. cone clutch.
- A cone clutch “oldest of all” Is a type of clutch system in which two mating members known as the male member and the female member designed in shape of cones are used, due to the mating of these 2 members frictional force due to the frictional contact between them is generated results in torque or power transmission between them.
- The engagement and disengagement of the male and female member of the cone clutch is controlled by the clutch pedal.

- Due to the large frictional area of contact and also due to the cone like shape of the male and female member of the cone clutch, This clutch system transmit high torque between the engine and the transmission shaft due to which it was widely used in heavy vehicles.

Need of a Cone Clutch

- As the clutch system is responsible for the torque or power transmission between the engine and the transmission shafts which makes it the one of the most important part of an automobile vehicle.
- This gives rise to the development of the cone clutch, so we need cone clutches because-
- Engine has its limitation to give a certain amount of torque and speed due to which a transmission was introduced and coupled with the engine shaft for this coupling between 2 shafts i.e. engine shaft and the transmission shaft cone clutch was used which made it possible to obtain different torque and speed ratios by connecting and disconnecting the above 2 shafts.
- Due to the high frictional force of contact and due to the complete interlocking between the male and the female member of the cone clutch, this clutch enables high torque transmission, even higher than the single plate clutch.
- In cone clutch ,The efforts need to keep the clutch engaged with the flywheel of the engine is less as the small axial force is required for engagement of the clutch, that is why they had been used in wide applications where high torque was the first priority.
- Due to its simple design as compared to other types of clutches which made it cost effective, they were widely used in small industries.
- As they provides high torque which is the need of some low speed off road vehicles specially off road all terrain vehicles , they are still used in some motor sporting off road vehicles.
- Due to their proper interlocking between female and the male clutch , cone clutches are used in various manual transmissions as a synchronisers.

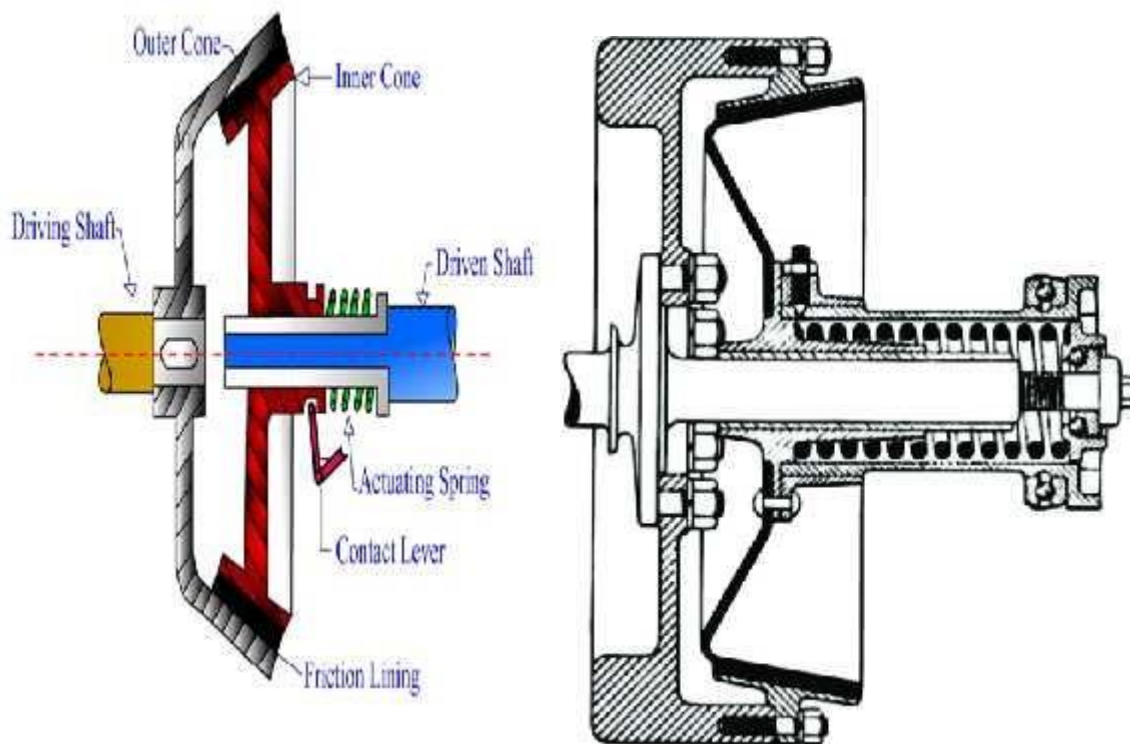

Main Components

- Female Cone- It is the part of a cone which is connected to the flywheel of the engine and also rotates with it, this cone is having inner cutting cone shaped groove over which the male cone interlocks and make frictional contact with it in order to engage the drive.
- Male Cone- It is the part of a cone clutch which is connected to the transmission shaft and is machined in the shape of a solid cone over which frictional material is attached. When the clutch pedal is released, Male cone makes contact with the female cone due to the spring action provided by the released spring behind it and the engagement of the drive takes place.
- Spring – Normal thrust spring located behind the male cone is used for engagement and disengagement of the clutch. When the clutch pedal is pressed, thrust spring compresses and the disengagement of the clutch takes place and the releasing of clutch pedal expands this spring due to which engagement of the clutch takes place.
- Shafts- The female cone which is directly attached to the flywheel is mounted over a solid shaft. The male cone on the other hand is mounted over the splined shaft.
- Sleeves- Sleeves having inner splines attached to the male cone mounted over the splined shaft is used for the to and fro motion of the male cone.
- Pedal– A clutch pedal operated by the driver is used for input regarding the engagement and the disengagement of the clutch. When the pedal is pressed, The pedal effort is transferred to the male clutch through the fulcrum attached at its other end which in turn compresses the spring and disengagement of the clutch takes place.
- Flywheel- It is the part of the engine used to store the engine output it can be considered the part of a clutch system as the female cone of the cone clutch is attached to the flywheel and rotates with it.

Working of Cone Clutch

Engagement

- When the clutch pedal is released the fulcrum attached to the other end of the pedal rotates and pushes the attached sleeve through which the male cone is attached outwards ,which in turn interlocks or make contact with the female clutch and finally the engagement of the clutch takes place.
- The stiffness provided by the thrust spring mounted behind the male clutch is used for continuous engagement of the clutch.

Disengagement

- When the driver presses the pedal in order to change gear the fulcrum attached rotates which in turn pulls the outer sleeve along with the male clutch attached to it.
- Due to this pull action provided by the clutch pedal, the thrust spring mounted behind the male cone compresses and finally the disengagement of the clutch takes place.

Application

- A leather-double cone clutch was used in Mercedes 37/90 PS in 1914.
- Mercedes Grand Prix Rennwagen used double cone clutch in 1914.
- Cone clutches are used in various manual transmissions as synchronisers.
- They are used in various heavy machines.

Advantages

- Normal force acting on the contact surface is larger than the axial force reduces the effort required to operate the clutch.

Disadvantages

- A small amount of wear on cone surface results in considerable axial movement of the male cone for which it will be difficult to allow

3. EXPLAIN THE CENTRIFUGAL CLUTCH AND SEMI-CENTRIFUGAL CLUTCH WITH NEAT SKETCH.

CENTRIFUGAL CLUTCH

- Centrifugal Clutch is type of clutch in which centrifugal force is used to connect engine drive shaft with the shaft of transmission. It is placed in between the engine flywheel and transmission system. Its main function is to connect the engine shaft with the transmission shaft. It works more efficiently at higher speeds.

Main Parts

The main parts of centrifugal clutch are

- Shoes: The shoes are of sliding types which slides in the guide ways. It consists of friction lining at the end and this friction lining makes contact with the drum during engagement.
- Spring: Spring is used to disengage the clutch when the engine rotates at lower speed.
- Spider or guides: The spiders are mounted on the driver (engine) shaft or motor shaft. The spiders are equally spaced. Equally spaced means, if they are four guides than each guide is separated from each other by 90 degree. The sliding shoes are kept in between these guides and each guide is holding a spring.
- Friction lining: The outer surface of sliding shoes has friction lining. It helps in making grip with the inner surface of the drum.
- Drum: The drum of the clutch act as housing which encloses all the parts of the clutch that includes sliding shoes, guides, springs etc. It is connected to the driven shaft of the transmission system or chains or belt.

Working Principle

- Its working is totally depends upon the centrifugal force created by the driving member (engine or motor).
- The centrifugal force is used to engage the clutch with driven shaft. As the engine starts rotating, it produces a centrifugal force which makes the sliding shoes to move outward.
- The friction lining of the shoes gets connected to the inner surface of the drum and it starts moving.
- Since the drum is connected to the driven shaft, so the power is transmitted from the engine shaft to the transmission shaft and finally to the load.

Working of Centrifugal Clutch

- As the engine rotates, the inside assembly of the centrifugal clutch starts rotating but drum remains stationary and no power is transmitted. At lower speed, the centrifugal force produced is not sufficient to overcome the spring force. So the clutch remains disengaged. But as the speed increases, the centrifugal force also increases and now the centrifugal force becomes greater than the spring force.
- As the centrifugal force becomes greater that the spring force, this allows the sliding shoes to move outward against the spring and get engaged with the inner surface of the drum.

- The drum starts rotating and transfer the rotating power from the engine to the driven shaft of the transmission.
- When the load on the engine increases, its speed decreases and disengages the clutch.

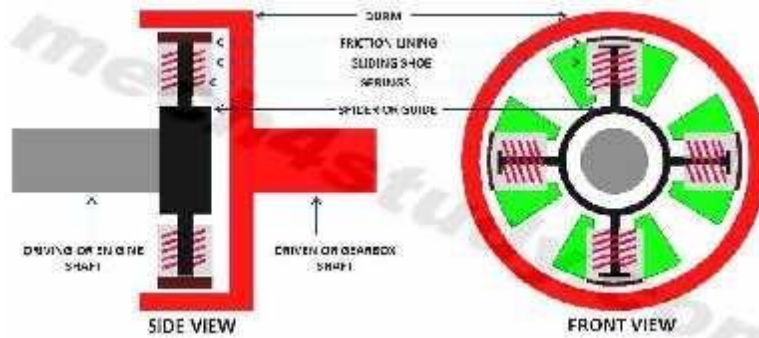

Advantages

- It is simple and requires less maintenance.
- It is inexpensive.
- Since it is automatic, so it does not need necessary control mechanism.
- Its engagement speed can be controlled by selecting appropriate spring.
- It helps to prevent the engine from stalling.

Disadvantages

- There is a loss of power in it due to slipping and friction.
- It is not capable of transferring high amount of power and it shoes slip in heavy load condition.
- It experiences overheating problem.
- Its engagement depends upon the speed of the driving shaft.

Application

- Centrifugal clutch is mainly used in lawn movers, mopeds, go karts, mini bikes, chainsaws etc. It is also used in some paramotors and boats to keep the engine running during stalling and disengage loads during starting and idling.
- If you find this article informative and useful than share and like it on Facebook

SEMI-CENTRIFUGAL CLUTCH:-

- A semi centrifugal clutch is used to transmit power from high powered engines and racing car engines where clutch disengagements requires appreciable and tiresome drivers effort.
- The transmission of power in such clutches is partly by clutch springs and rest by centrifugal action of an extra weight provided in system. The clutch springs serve to transmit the torque up to normal speeds, while the centrifugal force assists at speeds higher than normal.
- Besides clutch, pressure plate and splines shaft it mainly consists of:
 - ❖ Compression spring (3 numbers)
 - ❖ Weighted levers (3 numbers)

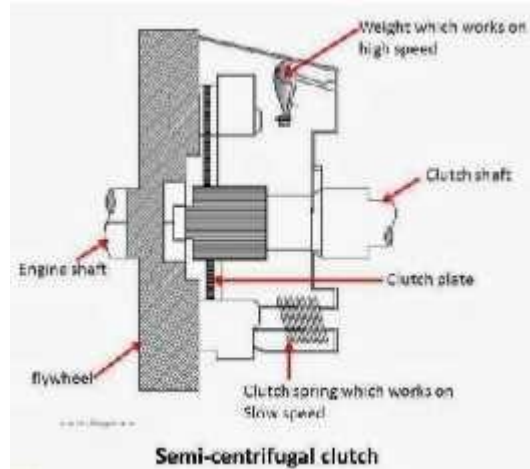

- At normal speeds when the power transmission is low the spring keeps the clutch engaged, the weighted levers do not have any pressure on the pressure plate. At high speed, when the power transmission is high the weights fly off and levers exert pressure on the plate which keeps the clutch firmly engaged. Thus instead of having more stiff springs for keeping the clutch engaged firmly at high speeds, they are less stiff, so that the driver may not get any strain in operating the clutch.
- When the speed decreases, the weights fall and the levers do not exert any pressure on the pressure plate. Only the spring pressure is exerted on the pressure plate which is sufficient to keep the clutch engaged.

4. EXPLAIN THE TORQUE CONVERTER WITH SUITABLE SKETCH.

- A torque converter is a type of fluid coupling which is used to transfer rotating power from the engine of a vehicle to the transmission. It takes place of mechanical clutch in an automatic transmission.
- The main function of it is to allow the load to be isolated from the main power source. It sits in between the engine and transmission. It has the same function as the clutch in manual transmission.
- As the clutch separates the engine from the load when it stops, in the same way it also isolates the engine from load and keep engine running when vehicle stops.

Its main functions are:

- It transfers the power from engine to the transmission input shaft.
- It drives the front pump of the transmission.
- It isolates the engine from the load when the vehicle is stationary.
- It multiplies the torque of the engine and transmits it to the transmission. It almost doubles the output torque.

Working Principle

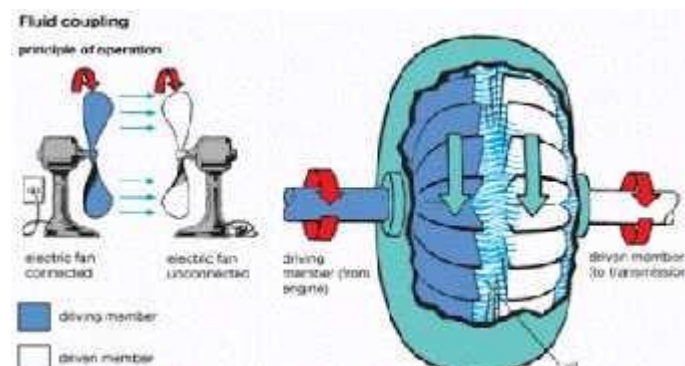

- For understanding the working principle of torque converter, let's take two fans. One fan is connected to the power source and other is not connected with power source. When first fan connected to the power source starts moving, the air from it flows to the second fan which is stationary.
- The air from the first fan strikes on the blades of the second fan and it also starts rotating almost at the same speed to the first one. When the second fan is stopped, it does not stop the first one. The first fan keeps rotating.
- On the same principle the torque converter works. In that the impeller or pump acts as first fan which is connected to the engine and turbine act as the second fan which is connected to the transmission system.
- When the engine runs, it rotates the impeller and due to the centrifugal force the oil inside the torque converter assembly directed towards the turbine. As it hits turbine blades, the turbine starts rotating. This makes the transmission system rotate and the wheels of the vehicle moves. When engine stops, the turbine also stops rotating but the impeller connected the engine keeps moving and this prevent the killing of engine.

Main Parts

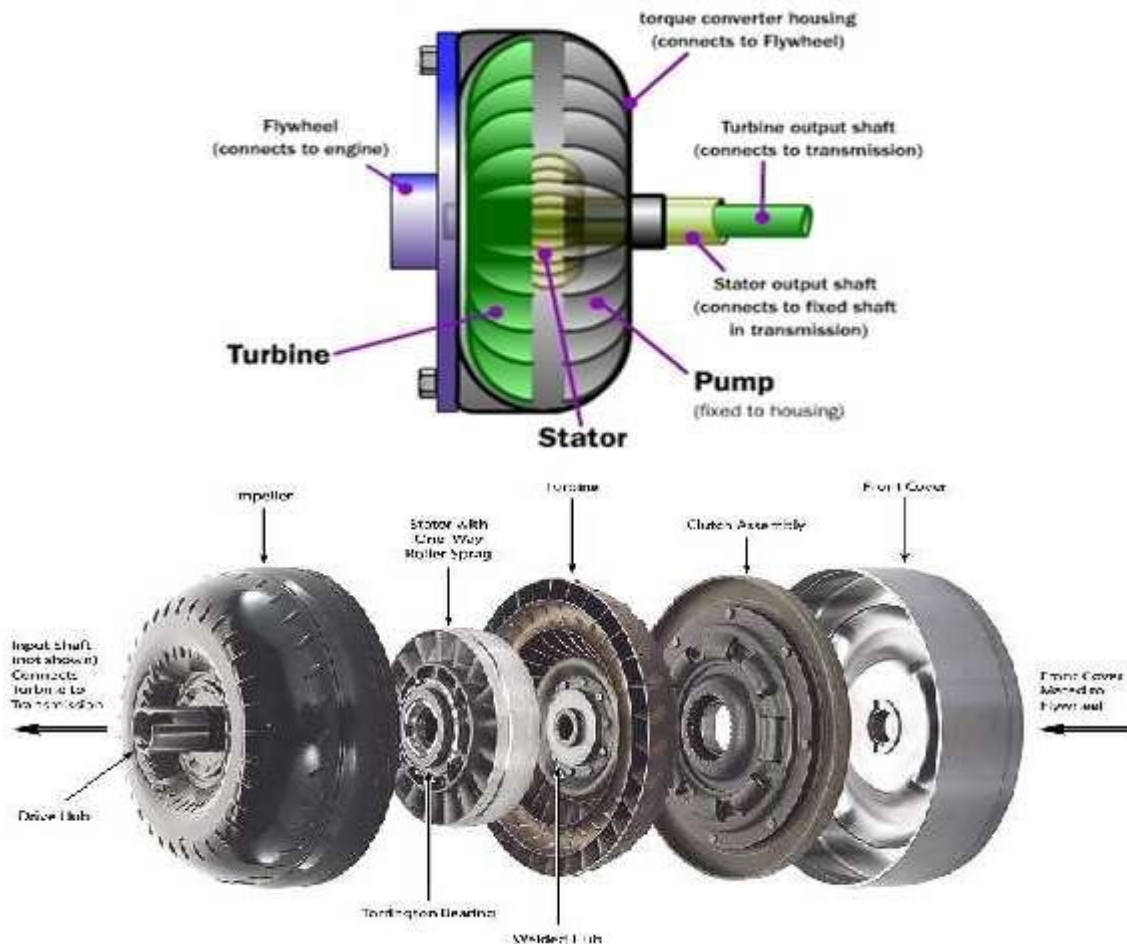

The torque converter has three main parts

1. Impeller or Pump

- The impeller is connected to the housing and the housing connected to the engine shaft. It has curved and angled vanes. It rotates with the engine speed and consists of automatic transmission fluid. When it rotates with the engine, the centrifugal force makes the fluid move outward.

- The blades of the impeller are designed in such a way that it directs the fluid towards the turbine blades. It acts as centrifugal pump which sucks the fluid from the automatic transmission and delivers it to the turbine.

2. Stator

- The stator is located in between the impeller and turbine. The main function of the stator is to give direction to the returning fluid from the turbine, so that the fluid enters to the impeller in the direction of its rotation.
- As the fluid enters in the direction of the impeller, it multiplies the torque. So stator helps in the torque multiplication by changing the direction of the fluid and allows it to enter in the direction of the impeller rotation.
- The stator changes the direction of fluid almost upto 90 degree. The stator is mounted with a one way clutch that allows rotating it in one direction and preventing its rotation in other direction. Turbine is connected to the transmission system of the vehicle. And the stator is placed in between the impeller and turbine.

3. Turbine

- Turbine is connected to the input shaft of the automatic transmission. It is present at the engine side. It also consists of curved and angled blades. The blades of the turbine are designed in such a way that it can change the direction of the fluid completely that strikes on its blades.
- It is the change in the direction of the fluid that forces the blades to move in the direction of the impeller. As the turbine rotates the input shaft of the transmission also rotates and made the vehicle to move. The turbine is also has a lock up clutch at its back.
- The lock up clutch comes into play when the torque converter achieves coupling point. The lockup eliminates the losses and improves the efficiency of the converter.

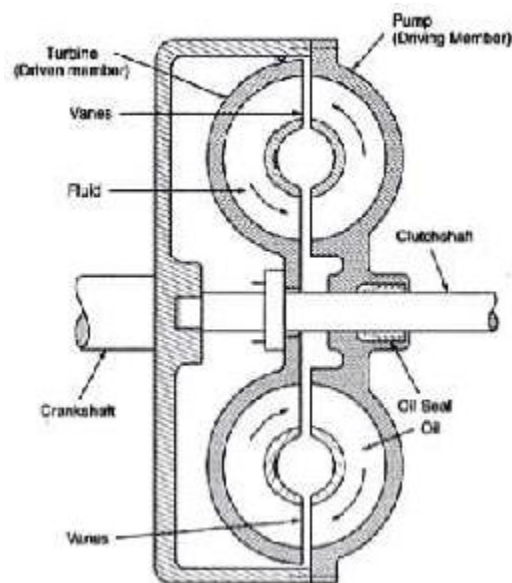

Working of Torque Converter

It has three stages of operations

- **Stall:** During stall (stop) condition of the vehicle, the engine is applying power to the impeller but the turbine cannot rotate. This happens, when the vehicle is stationary and driver has kept his foot on the brake paddle to prevent it from moving. During this condition maximum multiplication of torque takes place. As the driver removes its foot from the brake paddle and presses the accelerator paddle, the impeller starts

moving faster and this set the turbine to move. At this situation, there is a larger difference between the pump and turbine speed. The impeller speed is much greater than the turbine speed.

- Acceleration: During acceleration, the turbine speed keeps on increasing, but still there is large difference between the impeller and turbine speed. As the speed of the turbine increases the torque multiplication reduces. During acceleration of the vehicle the torque multiplication is less than that is achieved during stall condition.
- Coupling: It is a situation when the turbine achieved approximately 90 percent speed of the impeller and this point is called coupling point. The torque multiplication ceases and becomes zero and the torque converter behaves just like a simple fluid coupling. At the coupling point the lock up clutch come into play and locks the turbine to the impeller of the converter. This puts the turbine and impeller to move with the same speed. Lock up clutch engages only when coupling point is achieved. During coupling the stator also starts to rotate in the direction of the impeller and turbine rotation.

Note:

- The maximum torque multiplication takes place during stalling condition.
- The stator remains stationary before coupling point and helps in the torque multiplication. As the coupling attained, stator stops torque multiplication and starts rotating with the impeller and turbine.
- Lock up clutch engages when coupling point is achieved and removes the power losses resulting in increased efficiency.

Advantages

- It produces the maximum torque as compared with the vehicle equipped with clutch.
- It removes the clutch pedal.
- It makes the job of driving a vehicle easier.

Disadvantages

- Its fuel efficiency is low as compared with the vehicle with manual transmission.

Application

- The torque converter is used in the vehicle that is equipped with the automatic transmission. It is also used in industrial power transmission such as conveyer drives, winches, drilling rigs, almost all modern forklifts, construction equipment, and railway locomotives.
- It is used in marine propulsion systems.

6. EXPLAIN THE FLUID COUPLING WITH SUITABLE SKETCH.

- Fluid coupling is also known as hydraulic coupling is a hydrodynamic device which is used to transfer rotational power from one shaft to another by the use of transmission fluid. It is used in automotive transmission system, marine propulsion system and in industries for power transmission. It is used as an alternative for the mechanical clutch.
- It was discovered by Dr. Hermann Fottinger. He patented his discovery of fluid coupling and torque converter in the year 1950.

Main Parts

It consists of three main components

- Housing: It is also known as the shell. It has oil-tight seal around the drive shaft. It also protects the impeller and turbine from outside damage.

- Impeller or pump: It is a turbine which is connected to the input shaft and called as impeller. It is also known as pump because it acts as a centrifugal pump.
- Turbine: It is connected to the output shaft to which the rotational power is to be transmitted.
- The impeller is connected to the prime mover (internal combustion engine) which is a power source. The turbine is connected to the output shaft where rotation power is needed to be transmitted. The impeller and turbine is enclosed in an oil-tight sealed housing. The housing consists of transmission fluid.

Working Principle

- The working principle of fluid can be easily explained by the taking two fans in which one is connected to the power supply and other is not.
- When the power switch is ON, the air from the first fan is starts to blow towards the second fan (which is not connected to the power source).
- Initially when the first fan is blowing at lower speed, it does not able to drive the second fan. But as the speed of the powered fan increases, the speed of air striking the blades of second fan also increases and it starts to rotate.
- After some time it acquires the same velocity of that of the first fan. On the same principle the fluid coupling works. In that the impeller act as first fan and the turbine act as second fan. Both impeller and turbine enclosed in an oil tight housing.
- The impeller is connected the input shaft of the prime mover and the turbine with the output shaft. When the impeller is moved by the prime mover, the fluid in housing experiences centrifugal force and due to curved vanes of the impeller the fluid directed towards the turbine blades.
- As the fluid strikes the turbine blades it starts rotating. With the increase in the speed of impeller, the velocity of the turbine increases and becomes approximately equal to the impeller speed. The fluid after passing through the turbine blades again return to the impeller.

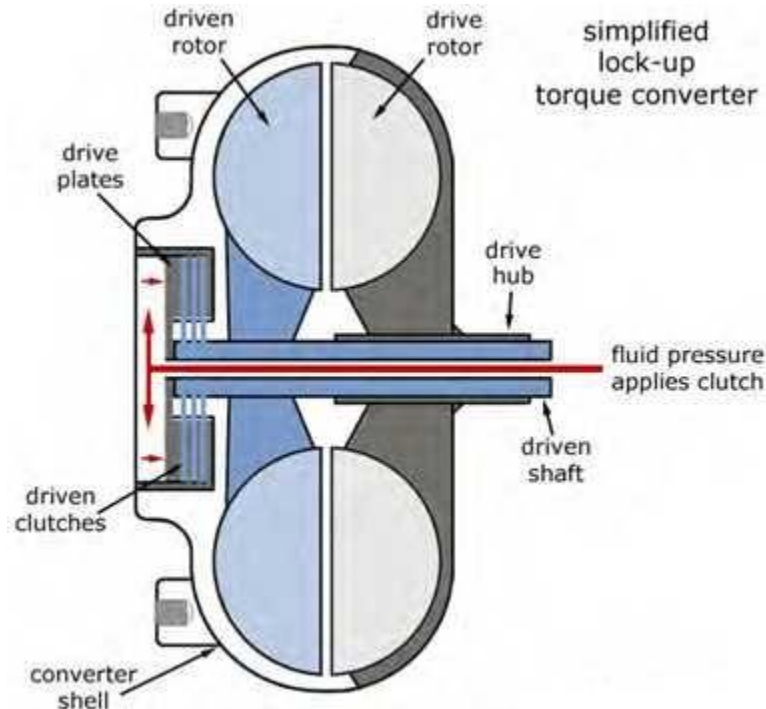

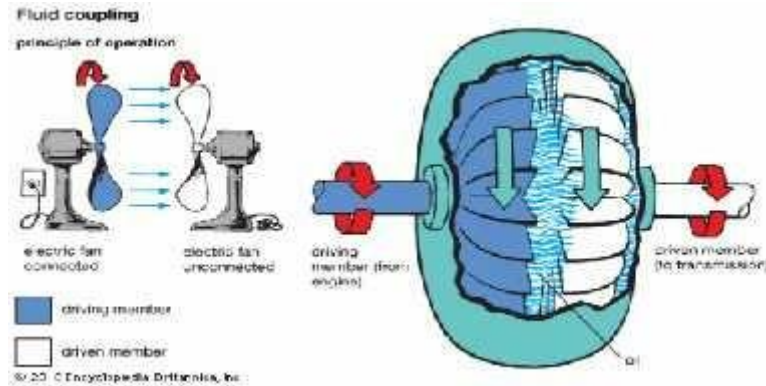

Working of Fluid Coupling

- As the prime mover moves, it rotates the impeller of the coupling. The impeller acts as a centrifugal pump and throws the fluid outward and directs it towards the turbine blade.
- As the high moving fluid strikes the turbine blades, it also starts rotating, after striking on the blades, the direction of the fluid is changed and it is directed towards the impeller again. The blades of turbine are designed in such a way that it can easily change the direction of the fluid. It is the changing of direction of the fluid that makes the turbine to rotate.
- As the impeller speed increases, the speed of the turbine also increases. After sometime the speed of both impeller and turbine becomes equal. In this way power is transmitted from one shaft to another by the use of fluid coupling.
- In same way torque converter works but the difference is that it has stator placed in between impeller and turbine for torque multiplication.

Application

- It is used in automotive industries for the transmission of power from the engine to the wheel as alternative of clutch.
- It is used in marine propulsion systems.
- It is used in various industries for the power transmission.

7. EXPLAIN THE WORKING OF SLIDING MESH GEAR BOX WITH NEAT SKETCH.

- “Old is gold” very rightly said as when it comes to an automobile old inventions are the source of improved technology which we are using today. One of those inventions is Sliding mesh gearbox which gave rise to a very essential system of an automobile i.e. transmission system or gearbox. But from where did the idea come from? How does it work? Let’s just find out.
- The idea of a transmission system is given by French inventors Louis-Rene and Emile Levassor who invented the world’s first ever transmission system with 3-speed sliding mesh transmission in 1894 which was the boom in the automobile industry.
- Sliding mesh gearbox is a transmission system that consists of various sets of gears and shafts that are arranged together in an organised fashion and the shifting or meshing of different gear ratios is done by the sliding of gears towards right and left over the splined shaft with the help of a gear lever operated by the driver.

Need of Sliding Mesh Transmission

- Introduction of an IC engine had led to the introduction of an automobile that was the replacement of the horse carriage which was used as the travelling medium by the people in early 18th century, but still the automobile was lacking behind when it came to face the challenges (turns, elevations, roughness etc.) given by the roads as there was no such mechanism fitted in early vehicles that could provide different torque and speed ratios as demanded by the road conditions.
- In 1894 the first transmission system named Sliding mesh transmission system was introduced which was designed to provide different speed and torque ratios to overcome those road challenges.

The various problem solved by this types of gearbox are-

- Fuel consumption of an automobile increased as the load on the engine is decreased or shared by the intermediate system known as sliding mesh gearbox.
- Due to the varying torque ratios provided by this gearbox, the automobile vehicle is made to go to the hill stations which was not possible earlier.
- Time taken to reach the destination was decreased as overall speed of the vehicle increased due to the high speed ratios provided by it.
- Reverse of the car made possible with the introduction of this transmission system.
- Jamming of vehicle due to the rough road conditions was solved after the introduction of the sliding mesh gear box.

Components of a Sliding Mesh Gearbox

(i) Shafts – Sliding mesh gearbox consists of 3 shafts that are-

- Main shaft- It is the shaft used as an output shaft in a sliding-mesh over which the sets of gears with internally splined grooves are arranged in an organised fashion. The outer surface of this shaft is made splined so that the gears can easily slide over this shaft in order to mesh with the appropriate gear.
- Clutch shaft- It is the shaft that is used to carry engine output to the transmission box with the help of engaging and disengaging clutch which is mounting at the engine end, gear or a pair of gear is mounted over this shaft which is used to transmit rotational motion to the lay shaft.
- Lay shaft- It is the shaft having gears mounted over its outer surface and is in continuous rotation with the clutch shaft as one gear of this shaft is always in contact with a gear on the clutch shaft, it is used as a intermediate shaft(between main shaft and clutch shaft)that provides the meshing of the gears of the main shaft in order to transmit appropriate output to the final drive.

(ii) Gears – 2 types of gear were usually used in sliding mesh gearbox.

1. Spur gear- This is the type of gears having straight cut teethes over its surface, straight teethes proving maximum meshing area.
2. Helical gear- This is the type of gear in which the teethes are cutted in angular fashion unlike spur gears this type of gears are smooth and less noisy.

(iii) Gear lever- It is the selecting mechanism operated by the driver in order to select the appropriate gear ratio, this liver is connected to the main shaft along with the selector forks.

Working of Sliding Mesh Gearbox

- The shifting of gears is obtained by the meshing of the gears on the main shaft with the gears on the lay shaft by right or left sliding of gears on the main shaft in order to obtain appropriate gears, lets understand the working of 3- speed 1-reverse transmission used in early automobile vehicles.

First gear

- First gear provide maximum torque at low speed which is obtained when the smallest gear on the lay shaft meshes with the biggest gear on the main shaft in order to provide high torque .

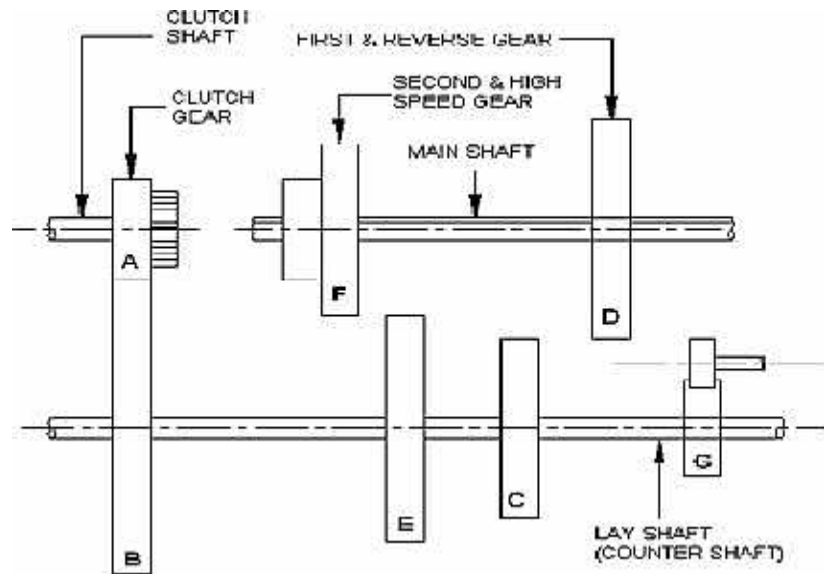

Second gear

- Second gear provides less torque and higher speed than first gear and is obtained when the middle size gear of the main shaft meshes with the second smallest gear on the lay shaft and high speed and second high torque is transmitted to the final drive.

Third gear

- Third gear provides maximum speed and minimum torque to the final drive and is also known as high speed gear or top gear in sliding mesh gearbox, this gear is obtained when the smallest gear of the main shaft meshes with the biggest gear of the lay shaft. Or we can say that the drive obtained maximum speed of the clutch shaft.

Reverse gear

- When the reverse gear is selected, the rotation of the output shaft is reversed which is made possible by using an idler gear between the main shaft and lay shaft that changes the rotation of the output shaft and the vehicle starts moving in reverse direction.

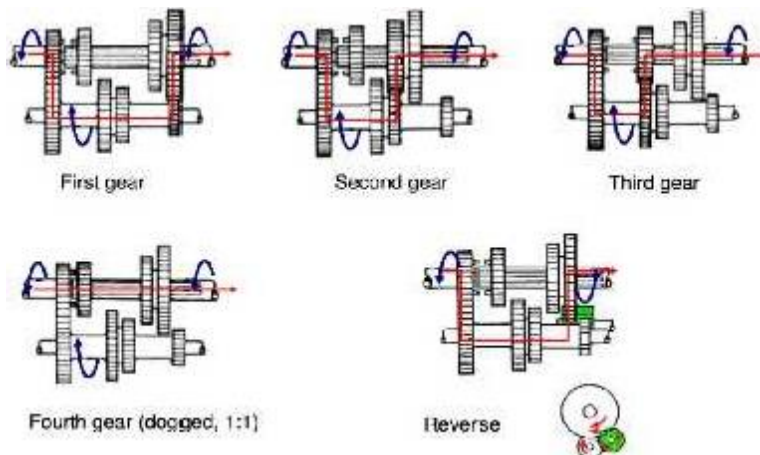

Application

It is the oldest type of gearbox used in early 19s models of cars.. Some of them are-

- Alfa 12HP used sliding mesh gearbox with 4 -speed manual transmission.
- Fiat 6HP used 3-speed manual transmission.
- Mercedes 35HP used 4-speed manual transmission
- Renault Voiturette used manual 3-speed transmission.

8. EXPLAIN THE WORKING OF CONSTANT MESH GEAR BOX WITH NEAT SKETCH.

- Constant mesh gearbox is used for the smooth working of an automobile. They are used to increase the rotating force (Torque); this is accompanied by a reduction in speed. It is a type of manual transmission.
- The invention of earliest manual gear system can be traced back to the nineteenth century. There are multiple gear ratios present which provides various torque and speed ratio. Along with this, the reverse mechanism is also present. These manual transmissions which are developed recently contain all the gears mesh at any given point of time.
- In technical terms, it can be defined as a gearbox in which all the gears are always in a state of mesh. The gears remain fixed at their original positions. The gears will remain engaged at all times. Learn more about its construction, working, advantages, disadvantages and applications in this article.

Construction:

It is made up of following components:

1. Counter shaft or Lay Shaft:

- This shaft is in direct contact with the clutch and the main shaft. Keeping in mind according to the gear ratio, the speed of the counter shaft may be less than the speed of the engine. The gear ratio can be defined as the ratio of the teeth of driven gear to the teeth of the driver gear.

2. Main shaft:

- This shaft operates the speed of the vehicle. The power is made available to the main shaft through the gears from the counter shaft. This is done in accordance with the gear ratio.

3. Dog clutch:

- Dog clutch is special feature of constant mesh gearbox. It is used for the coupling of any two shafts. This is done by interference. Using a dog clutch, various gears can be locked to the output and input shafts.

4. Gears:

- The main work of the gears is the transmission of power between the shafts. If the gear ratio is more than one, the main shaft will work at a speed that is slower than the counter shaft, and vice versa. The arrangement of both reverse, as well as forward gears is present.

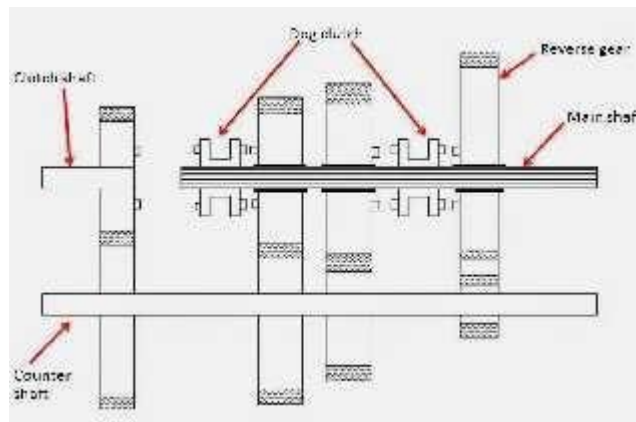

Working:

Forward gear selection:

- From the input shaft, the power starts flowing and is divided into four parts. Each part goes to one of the output gears, namely first, second, third and fourth. Gear ratios can be obtained for each of them.
- This can be done by the proper sliding of dog clutch over the teeth of the selected gearwheel. After this the path of the energy flow completes. This happens due to the locking movement of the output shaft.

Reverse gear selection:

- The power will flow from the input shaft to the reverse gears. The power is then transmitted from the reverse gear to the reverse idler. The idler wheel will change the direction of the rotation.
- In the case of forwarding direction gear selection, the output gears will rotate in a direction opposite to the input gears. But in the case of reverse gear selection, the rotation is in the same direction as the input shaft.

The steps are taken to change any gear in the constant mesh gearbox system:

- The first step when one wants to modify the gear would be the pressing of the clutch. After this comes the neutral state of the vehicle to be achieved. Proper optimization of the engine's speed is required.
- After the neutral gear, one moves forward to the first gear. The first gear. This process is known as double clutching. Inefficiency in performing the above steps might lead to a harsh and gnashing sound.

Advantages:

- The first and foremost benefit of the constant gear mesh is the utilization of helical gears. The double helical gears and the helical gears are extremely beneficial owing to their quieter operating capabilities
- There are various conditions which might cause harm. In the case of constant mesh gearbox, any harm is suffered entirely by the dog clutch teeth. The teeth belonging to the gear wheels remain intact. This is not the case for sliding mesh gear box.
- The other gear boxes are noisy and create an unwanted din.

Disadvantages:

- It is less efficient than the others due to higher mesh teeth. Skill is required for it.
- The double clutch mesh is required. This is required to have the spinning movements of the shaft.

Application:

- Some of the vehicles which use this type of gearboxes are farm trucks, motorcycles, and heavy machinery.
- It is very evident that the world today is full of vehicles and relies on this mode of transport. The availability of such mechanisms like constant mesh gearbox which create less noise and are cost effective is a boon for the people. If you like these articles don't forget to share it on social networks. Subscribe our website for more informative articles. Thanks for reading it.

9. EXPLAIN THE WORKING PRINCIPLE OF SYNCHROMESH GEAR BOX WITH NEAT SKETCH.

- Modification in a component keep occurring until the ideal or near to ideal state of the component is not achieved so with this thought in mind engineers keep on researching on manual transmission to get the best out of it, which leads the researchers from the General Motors to the development of synchromesh gear box or transmission system in 1928, this system overcame the limitations of later transmission system and gave the answers to all the transmission related question, let's find more about it.
- Synchromesh gearbox or transmission system is a type of transmission system in which the dog clutches from the constant mesh gearbox is replaced with the special shifting devices known as synchromesh devices which makes the system compact and also provide smooth and noise free shifting of gears .

- In synchromesh transmission the pair of gears which has to be used for final transmission of output first bring in frictional contact with the synchromesh device and then final selection of the appropriate gear takes place.
- It usually comes with the 5-speed 1-reverse manual transmission configuration for example- Maruti Suzuki swift.
- With suitable modification in shifting lever mechanism synchromesh gearbox is also used in racing cars like formula-1, because of its quick and smooth response.

Why do we Need Synchromesh Gearbox?

- Since, the introduction of the transmission system from sliding mesh to constant mesh various modification is made in both the systems to make them smooth ,less noisy and to make the shifting response quick, though the constant mesh overcame the important limitations of sliding mesh gearbox like double-de-clutching, wear and tear but still has its own limitations, let's discuss them:
- The response to the shifting of gears in the constant mesh gearbox is not quick as the dog clutches used in constant mesh gearbox has to mesh with the rotating pair of gears which is not a quick task.
- There is a lack of mechanism in constant mesh gearbox that can bring all the rotating shafts that are clutch shaft, main shaft and lay shaft at the same rotating speed, which is responsible for the harsh shifting.
- The teethes of the dog clutches shows wear and tear which in turn increases the maintenance of the system.
- The shifting in constant mesh gearbox is a noisy process as the dog clutches has to make contact with rotating gear pair.
- The constant mesh gear box is not compact as compared to synchromesh gearbox. These problems lead General Motors to develop synchromesh gearbox which is still used in almost 52% of the automobile vehicles on the road today.

Main Components

1. Shafts – Just like constant mesh gearbox, there are 3 shafts used in synchromesh gearbox-

- Main shaft- Same as constant mesh a splined shaft is used as the output shaft over which the synchronizers and gears are mounted.
- Lay shaft- It is the intermediate shaft over which gears with suitable size and
- Teethes are mounted and is used to transmit the rotational motion from clutch shaft to the final output shaft.
- Clutch shaft- It is the shaft used as an input shaft in gearbox as it carries the engine output to the gearbox, same as the constant mesh gearbox

2. Gears- There are normally 2 types of gears used in this –

- Helical gears- These gears are having angular cut teethes over a cylindrical metal flank.
- Bevel gears – These gears are having angular cut teethes over a conical metal flank.

3. Synchronizers –They are the special shifting devices used in synchromesh gearbox which has conical grooves cut over its surface that provide frictional contact to the gears which is to be meshed in order to equalise the speed of main shaft, lay shaft and clutch shaft which in turn provides smooth shifting of gears.

4. Gear lever – It is the shifting lever operated by the driver and is used to select the appropriate gear i.e. 1, 2, 3, 4, 5 or reverse gear.

Working

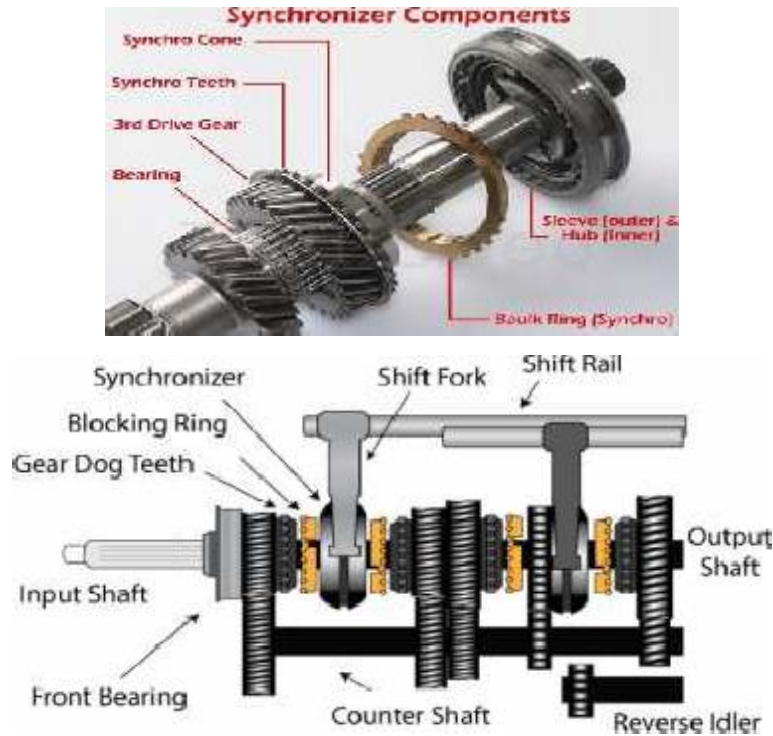

Selecting gears in synchromesh gearbox is somewhat same as constant mesh gearbox that are-

First gear

- When the driver push or pull the gear lever in order to select the first gear which gives the maximum torque and minimum speed and is used to move the vehicle from its initial state, the synchromesh device attached with the pair of meshed gears having biggest gear of the main shaft and smallest gear of the lay shaft equalizes the speed of the shafts by making frictional contact with the pair and finally the first gear is obtained.

Second gear

- This is the gear having lower torque and higher speed than first gear and is obtained when the pair of gears having second largest gear of the main shaft and second smallest gear of the lay shaft is meshed by the corresponding synchromesh device.

Third gear

- This gear having higher speed and lower torque than second gear is obtained when the corresponding synchromesh device attached to the pair of gear having intermediate size gear of main shaft and intermediate size of gear of lay shaft makes contact.

Fourth gear

- It is the second highest speed gear which is obtained when the corresponding synchromesh device attached to the pair of meshed gears having second smallest gear of main shaft and second largest gear of the lay shaft makes contact.

Fifth gear

- It is the highest speed and lowest torque gear which transmit the maximum speed of the clutch shaft to the main or output shaft and is obtained when the corresponding synchromesh device attached to the pair of meshed gear having smallest gear of main shaft and largest gear of lay shaft makes contact.

Note – In some vehicle like ktm duke 390cc over drive is attached which directly obtained the output from the clutch shaft and transmit to the final drive when the vehicle is on a long run with high speed or when the vehicle is going down the hill.

Reverse gear

- It is the gear that reverses the direction of the output shaft which in turn reverse the direction of the vehicle with the help of the idler gear which is usually fit in the middle of the lay shaft and main shaft and is obtained when the idler gear makes contact with the gears on the main shaft and lay shaft.

Note – The reverse gear does not have any synchronizer mechanism, so the gearbox shaft rotation is completely stop before engaging the reverse gear.

Application

- It has a wide application as almost 50% of the vehicle on the road used synchromesh gearbox, some of them are-
- In Maruti Suzuki swift it comes with 5-speed 1-reverse manual transmission configuration.
- It is used in bikes like ktm duke 390cc.
- Most of the race cars like formula-1 uses synchromesh gearbox with suitable modification in shifting lever as they required sudden shifting of gears from high torque to high speed because they have to race onto the zig-zag track having sharp turns.

10. EXPLAIN THE WORKING PRINCIPLE OF EPICYCLIC GEARBOX WITH NEAT SKETCH.

- “Automatic is the new need of the 21st century” yes it is, when it comes to human comfort various researches is being done to decrease the human effort in operating the machines though the manual transmission has its own benefits but some people find it causes fatigue to the driver in operating the clutch and shifting gear continuously during a drive which raises questions like why do we need clutch? Why there are limited torque and speed ratios? , Which leads to the introduction of automatic type gearbox named Epicyclic gearbox.
- An Epicyclic gearbox is an automatic type gearbox in which parallel shafts and gears arrangement from manual gear box are replaced with more compact and more reliable sun and planetary type of gears arrangement and also the manual clutch from manual power train is replaced with hydro coupled clutch or torque convertor which in turn made the transmission automatic.
- The idea of epicyclic gear box is taken from the solar system which is considered to the perfect arrangement of objects.
- The epicyclic gearbox usually comes with the P N R D S a (Parking, Neutral, Reverse, Drive, and Sport) mode which is obtained by fixing of sun and planetary gears according to the need of the drive.

Why do We Need Epicyclic Transmission?

- When it comes to luxury, human comfort becomes the first priority, since in manual transmission driver has to press and release the clutch pedal and shifts gears continuously for shifting the drive from high torque to high speed and also the sliding and meshing of lots of mechanical components is there in manual transmission which raises many problems that are-

- In countries like India there is a problem of traffic which required sudden shifting of gears from high torque to high speed which in turn requires continuous engagement and dis-engagement of the clutch which causes fatigue to the driver.
- Poor fuel economy is the problem seen with the synchromesh manual transmission as there is the loss of energy due to the movement of lots of components and also over raving of accelerator is also seen in it.
- Since, the parallel shafts with mounted gears and meshing devices are used in manual transmission so size of the gearbox becomes the problem.
- When we talk about manual synchromesh transmission we can have maximum of 6 gear ratios but it is found that a car requires more than 6 gear ratios in a long run.
- If we take an example of the latest manual transmission system i.e. synchromesh gearbox in which the shifting of gears is obtained by sliding and meshing of synchronisers with the constantly meshed pairs of gears which causes wear and tear to the transmission system.
- Also in manual transmission the shifting of gear is a noisy process. So with these problem in mind General Motors developed the first automatic transmission in 1930 by using epicyclic gear train with hydraulic coupling which was boom in the luxury cars world.

Components of Epicyclic Gearbox

- Ring gear- It is a type of gear which looks like a ring and have angular cut teethes at its inner surface ,and is placed in outermost position in en epicyclic gearbox, the inner teethes of ring gear is in constant mesh at outer point with the set of planetary gears ,it is also known as annular ring.
- Sun gear- It is the gear with angular cut teethes and is placed in the middle of the epicyclic gearbox; the sun gear is in constant mesh at inner point with the planetary gears and is connected with the input shaft of the epicyclic gear box.

One or more sun gears can be used for achieving different output.

- Planet gears- These are small gears used in between ring and sun gear , the teethes of the planet gears are in constant mesh with the sun and the ring gear at both the inner and outer points respectively. The axis of the planet gears are attached to the planet carrier which is carrying the output shaft of the epicyclic gearbox.nThe planet gears can rotate about their axis and also can revolve between the ring and the sun gear just like our solar system.
- Planet carrier- It is a carrier attached with the axis of the planet gears and is responsible for final transmission of the output to the output shaft.The planet gears rotate over the carrier and the revolution of the planetary gears causes rotation of the carrier.
- Brake or clutch band- The device used to fix the annular gear, sun gear and planetary gear and is controlled by the brake or clutch of the vehicle.

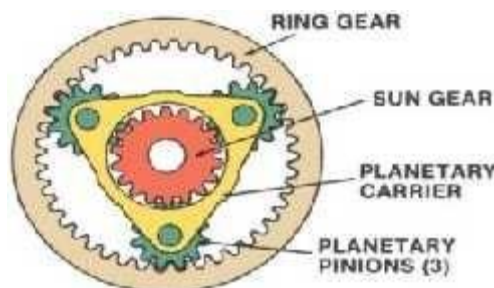

Working of Epicyclic Gearbox

- The working principle of the epicyclic gearbox is based on the fact the fixing any of the gears i.e. sun gear, planetary gears and annular gear is done to obtain the required torque or speed output. As fixing any of the above causes the variation in gear ratios from high torque to high speed. So let's see how these ratios are obtained

First gear ratio

- This provide high torque ratios to the vehicle which helps the vehicle to move from its initial state and is obtained by fixing the annular gear which in turn causes the planet carrier to rotate with the power supplied to the sun gear.

Second gear ratio

- This provides high speed ratios to the vehicle which helps the vehicle to attain higher speed during a drive, these ratios are obtained by fixing the sun gear which in turn makes the planet carrier the driven member and annular the driving member in order to achieve high speed ratios.

Reverse gear ratio

- This gear reverses the direction of the output shaft which in turn reverses the direction of the vehicle, this gear is achieved by fixing the planet gear carrier which in turn makes the annular gear the driven member and the sun gear the driver member.

Note- More speed or torque ratios can be achieved by increasing the number planet and sun gear in epicyclic gear box.

Application

- Epicyclic gear train is usually used in automatic vehicles with the hydraulic clutch.
- Epicyclic gearbox is used in automatic model of Audi A4
- It is used Lamborghini Gallardo. It is also used in power transmission between I.C engine and electric motor, so it also has its uses in hybrid cars.

S. No	Manual Transmission	Automatic Transmission
1.	In the manual transmission the shifting of the gears is done by the driver.	In the automatic transmission the shifting of gears is done by the car itself.
2.	The cost of the manual transmission cars is less.	The cost of automatic transmission cars is much higher than the MT cars.
3.	The maintenance cost is less	The maintenance cost is high
4.	It does not require active cooling.	It requires active cooling due to overheating problem.
5.	The fuel efficiency of manual transmission is more. It depends upon the driving skills of the driver.	The fuel efficiency is less as compared with the manual transmission.
6.	The design is simple and less complex.	The design is more complex due to number of components.
7.	Different sets of gears are present to get different gear ratios.	Same set of gears produces all of the different gear ratios.
8.	Manual transmission cars are not easy to drive.	Cars with automatic transmission are much easier to drive.

9.	High skilled driver is required to drive MT cars.	Less skilled driver can also drive AT cars.
10.	Requires more attention of the driver to operate manual transmission cars.	Not much attention is required to operate automatic transmission cars.
11.	Clutch pedal is used to shift the gears.	No clutch pedal is there, automatic shifting of gears takes place according to the speed of the car.
12.	It does not allow multitasking during driving.	It allows multitasking during driving.
13.	It gives you more ways to control your car.	It does not provide you more ways to control your car.
14.	In manual transmission cars there is three pedals to operate the car. These three pedals are of clutch, brakes and acceleration.	In the automatic transmission cars there is two pedals to operate the car. These two pedals are of brake and accelerator.
15.	It has low resale value.	It has high resale value.
16.	It is not easier to drive on steep hills.	It is easier to drive on steep hills.
17.	The MT cars are difficult to operate in high density traffic area due to manual changing of gears.	The AT cars are very easier to operate in the high density traffic area due to automatic changing of gears by the car itself.

11. EXPLAIN THE PRINCIPLE AND WORKING OF A DIFFERENTIAL WITH A NEAT SKETCH.

- A differential is a mechanical device capable of transmitting torque and make rotation through three shafts, one as input and other two are as output for different speed as vehicle makes turn.
- The differential allows each of the driving wheels to rotate at different speeds, while supplying equal torque to each of them. The differential is found on all modern cars and trucks, and also in many all-wheel-drive vehicles.
- These all-wheel-drive vehicles need a differential between each set of drive wheels, and they need one between the front and the back wheels as well, because the front wheels travel a different distance through a turn than the rear wheels.

Purpose

- A vehicle's wheels rotate at different speeds, mainly when turning corners. The differential is designed to drive a pair of wheels with equal torque while allowing them to rotate at different speeds.
- In vehicles without a differential, such as racing motor both driving wheels are forced to rotate at the same speed, usually on a common axle driven by a simple chain-drivemechanism. When cornering, the inner wheel needs to travel a shorter distance than the outer wheel, so with no differential, the result is the inner wheel spinning and/or the outer wheel Dragging, and this results in difficult and unpredictable handling, damage to tires and roads, and strain on the entire drivetrain.
- The problem was solved in 1827 by Pequer of France who invented the differential. This mechanism rotates the wheels at different speeds, while maintaining a drive to both wheels.

Various Parts of the differential

- Pinion Drive Gear: It transfers power from the driveshaft to the ring gear mainly having helical gear on it.

- Crown wheel/ring gear: Ring gear transfers power from pinion gear to the differential case assembly. Ring gear reduces the gear ratio that helps in increasing the torque value. Crown wheel and pinion gear are meshes with hypoid gear orientation. A hypoid gear is a style of spiral bevel gear whose main variance is that the mating gears' axes do not intersect. The hypoid gear is offset from the gear center, allowing unique configurations and a large diameter shaft. The teeth on a hypoid gear are helical, and the pitch surface is best described as a hyperboloid.
- Spider/planet gear: spider gears are connected at the end of the cross-pin that transfers power from ring gear to side gear. The spider gear lies at the heart of the differential, and special mention should be made about its rotation. The spider gear is free to make 2 kinds of rotations: one along with the ring gear (rotation) and the second on its own axis (spin). This two kinds of rotations are shown in figure.
- Cross-pin: It link the spider gear with the crown wheel so spider gear can make rotation through crown wheel.
- Side/sun gear: It transfer power from spider gear to rear axles and help both wheels to turn independently when turning.
- Differential case assembly: It holds the ring gear and other components that drive the rear axle.

Construction of differential gear:

- Differential is an arrangement of gears which work together and allow the vehicle to take a turn smoothly. In the differential, bevel pinion gear is fixed to the propeller shaft which rotates the crown wheel.
- The crown wheel has another unit called the differential unit. It consists of two bevel gears (sun gear) and two bevel gears (planet gear). The bevel gears are in contact with the half shaft of the rear axle. When the crown wheel is rotating, it rotates the differential unit. The bevel (sun) gears of the differential rotate the two shafts.

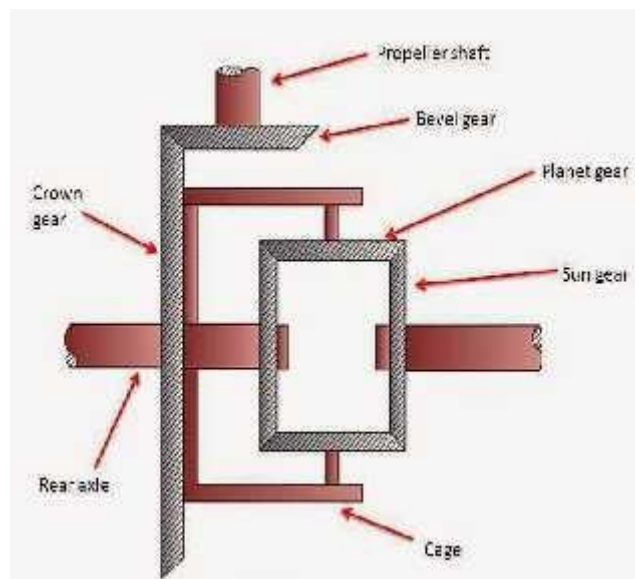

Working of differential gear:

Now let's see how the differential manages to rotate the side gears at different speeds as demanded by different driving scenarios. Consider three different cases

- Vehicle moves in straight direction
- Vehicle takes right turn

- Vehicle takes left turn
- Vehicle moves in straight direction

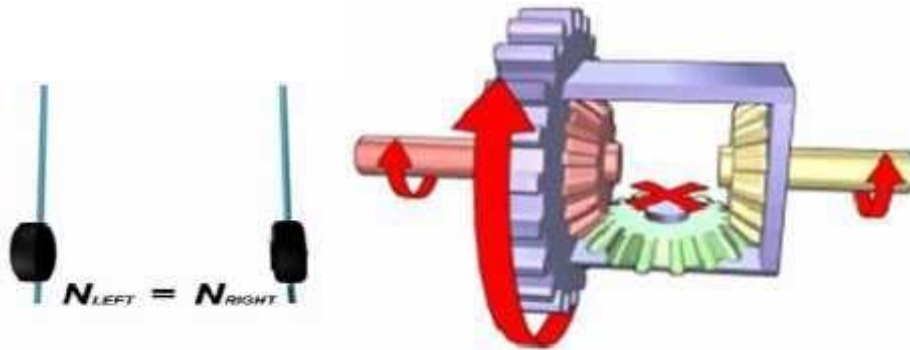

- In this case, both right and left wheel have to travel same distance so same speed is require. Input torque is applied to the ring gear (blue), which turns the entire carrier (blue), providing torque to both side gears (red and yellow), which in turn may drive the left and right wheels.
- If the resistance at both wheels is equal, the spider gear (green) does not spin, and both wheels turn at the same rate. The spider gear rotates along with the ring gear but does not rotate on its own axis. So the spider gear will push and make both the side gears turn, and both will turn at the same speed. In short, when the vehicle moves straight, the spider-side gear assembly will move as a single solid unit.

Vehicle takes right turn

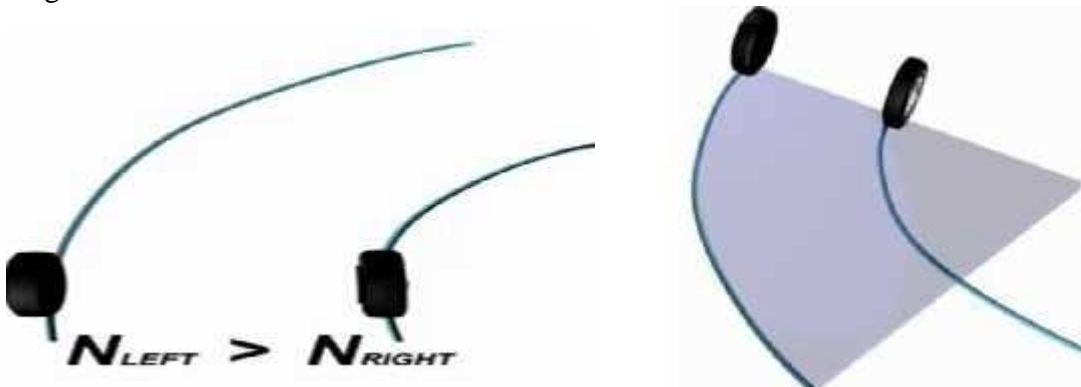

Travelling distance of wheels during right turn

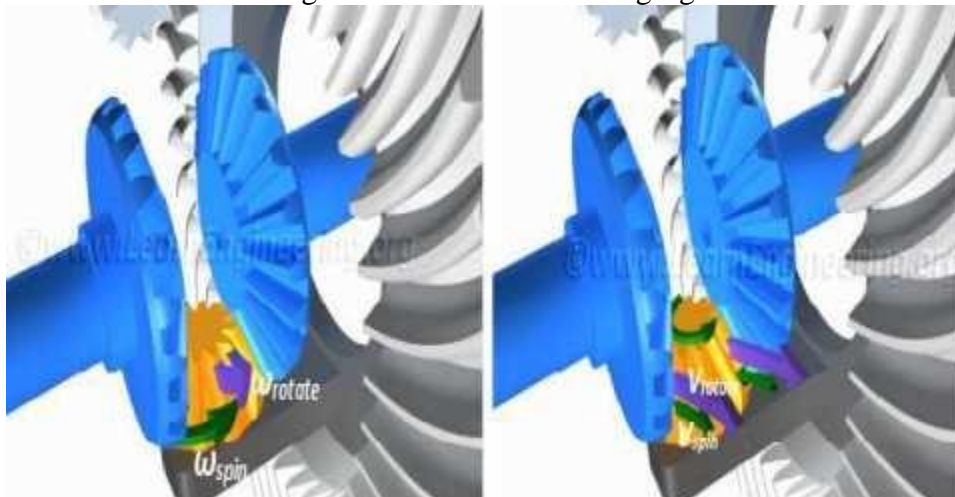

Direction of rotation of spider gear during right turn

- Now consider the case when the vehicle is taking a right turn. In this case a certain amount of tension would build up when cornering as the outside wheel tries to rotate quicker than the inside wheel due to the bigger arc of travel.
- The spider gear plays a pivotal role in this case. Along with the rotation of the ring gear it rotates on its own axis. So, the spider gear has a combined Rotation. Here during right turn left wheel have to travel more than the right wheel so the speed or require to left wheel is more. When properly meshed, the side gear has to have the same Peripheral velocity as the spider gear.
- When the spider gear is spinning as well as rotating, peripheral velocity on the left side of spider gear is the sum of the spinning and rotational Velocities. But on the right side, it is the difference of the two, since the spin velocity is in the opposite direction on this side. This fact is clearly depicted in Fig. This means the left side gear will have higher speed compared to the right side gear. This is the way the differential manages to turn left and right wheels at different speeds.

Vehicle takes left turn

- Now consider the case when the vehicle is taking a left turn. Here the right wheel have to travel more distance than left wheel that require more rotational speed of the wheel.
- In this case the speed of spider gear is in opposite direction as compare to previous case shown in figure So the speed of the right sun gear will more because of sum of spinning and rotational velocity of spider gear and contrast to the left side gear. This means the right side gear will have higher speed compared to the left side gear.



Travelling distance of wheels and direction of rotation of spider gear during left turn

Use of more Spider gears

- In order to carry a greater load, one more spider gear is usually added. The spider gears should spin in opposite directions to have the proper gear motion. A four-spider-gear arrangement is also used for vehicles with heavy loads. In such cases, the spider gears are connected to ends of a cross bar, and the spider gears are free to spin independently.



Double spider gear arrangement

Other functions of the Differential

- Apart from allowing the wheels to rotate at different rpm differential has 2 more functions. First is speed reduction at the pinion-ring gear assembly. This is achieved by using a ring gear which is having almost 4 to 5 times number of teeth as that of the pinion gear. Such huge gear ratio will bring down the speed of the ring gear in the same ratio. Since the power flow at the pinion and ring gear are the same, such a speed reduction will result in a high torque multiplication.
- One specialty of the ring gear, they are hypoid gears. The hypoid gears have more contact area compared to the other gear pairs and will make sure that the gear operation is smooth.
- The other function of the differential is to turn the power flow direction by 90 degree. In which the power is transmitted to differential by main shaft and that power further transmitted to rear axles that are mounted at 90 degree with the main shaft.

12. EXPLAIN THE TYPES OF REAR AXLE DRIVE WITH SUITABLE SKETCH.

- The rear drive axle connects the differential side gears to the drive wheels. The axle may or may not support the weight of the vehicle. Rear axles are normally induction hardened for increased strength.
- There are several types of rear axle designs: semi floating, three-quarter floating, and full floating. However the semi- and full-floating types are the most common. Most automobiles use the semi floating type, whereas four-wheel drive vehicles and trucks use full floating axles.

SEMIFLOATING AXLE

- The semi floating axle is used in passenger vehicles and light trucks. In vehicles equipped with this type of axle, the shaft, as well as the housing, supports the weight of the vehicle. The inner end of the axle is carried by the side gears in the differential housing. This relieves the axle shafts of the weight of the differential and the stresses caused by its operation that are taken by the axle housing. The inner ends of the axle transmit only turning effort, or torque, and are not acted upon by any other force.
- The outer end is carried by a bearing located between the shaft and the housing. A tapered roller or ball-type bearing transfers the load from the shaft to the housing. The axle shafts take the stresses caused by turning, skidding, or wobbling of the wheels.
- The axle shafts are flanged or tapered on the ends. When the tapered axle is used, the brake drum and hub are pressed onto the shafts, using keys to prevent the assemblies from turning on the shafts. In some cases, the outer ends of the shafts may have serrations or splines to correspond with those on the drum and hub assembly. Should the axle break with this type of axle assembly, the wheel can separate from the vehicle.

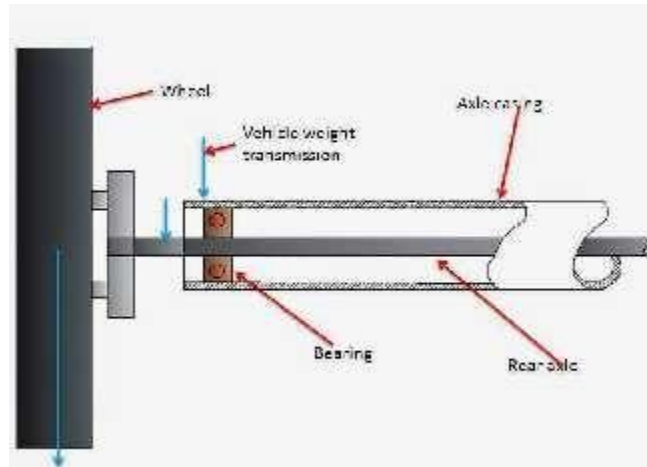

Advantages

- The semi floating axle is the simplest and cheapest and they are widely used in cars. □

Disadvantages

- The axle has to be designed for carrying higher loads i.e. they are of higher diameter for the same torque transmitted by other types of axle supporting.

FULL-FLOATING AXLE

- The full-floating axle is used in many heavy-duty trucks. The drive wheel is carried on the outer end of the axle housing by a pair of tapered roller bearings. The bearings are located outside the axle housing. In this way, the axle housings take the full weight of the vehicle and absorb all stresses or end thrust caused by turning, skidding, and pulling. Only the axle shaft transmits torque from the differential.

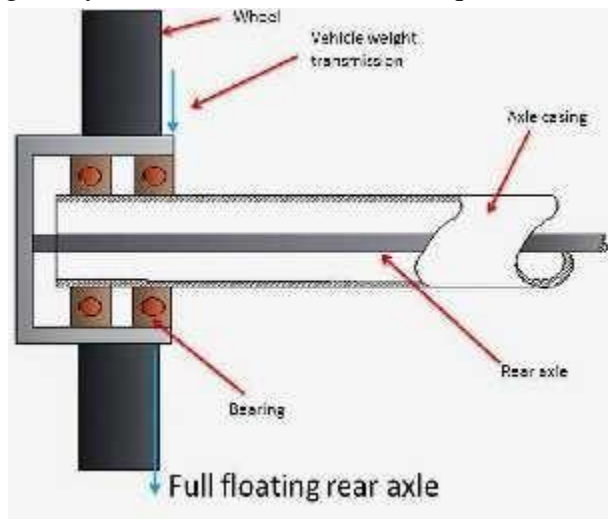

- The axle shaft is connected to the drive wheel through a bolted flange. This allows the axle shaft to be removed for servicing without removing the wheel.

Advantages

- These are very robust type and are used for heavy vehicles.
- Axle shaft carry only the drive torque so their failure does not affect the vehicle wheels. □
- Vehicle can be towed with the broken axle shaft.
- Axle shaft can be replaced by without jacking.

Disadvantages

- Costliest type of axles up porting.

THREE QUARTER FLOATING REAR AXLE:

- In this axle bearing are on the outer side of casing between the wheel and the axle casing. The wheels are fitted at the end of the axle by means of a key, bolt or nut. The weight of the vehicle is supported partly by the axle casing and partly by the axle. The main advantage of this type of axle over the half floating axle is that the major part of the load is taken by the axle casing and not by axle. Axle only takes care of the rotating and transmits the power.

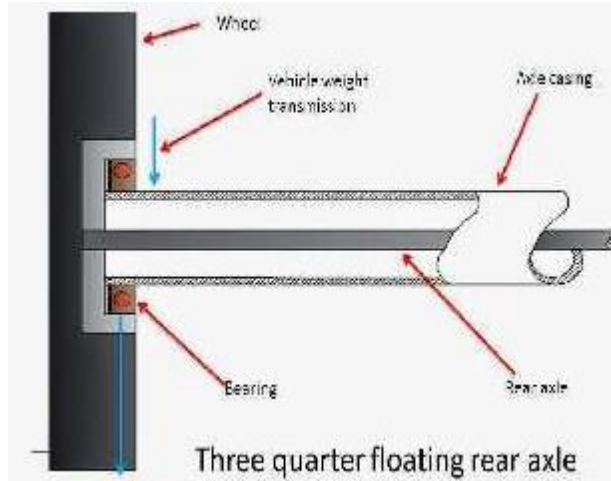

Advantages

- At one time this axle type was commonly used for cars and light commercial vehicles.

Disadvantages

- These axles are no longer preferred. instead semi floating axles are used.

Functions of final drive:

- Transmits the drive through an angle of 90°.
- Gears down the engine revolution to provide a ‘direct top’ gear ratio. In the case of cars a final drive ratio of approximately 4:1 is used. Bevel or worm gears are employed to achieve the various functions of the final drive.

13. EXPLAIN IN DETAIL WITH NEAT SKETCHES ABOUT HOTCHKISS DRIVE AND TORQUE TUBE DRIVE.

HOTCHKISS DRIVE:

- The Hotchkiss drive is simplest and most popular form of rear axle suspension.

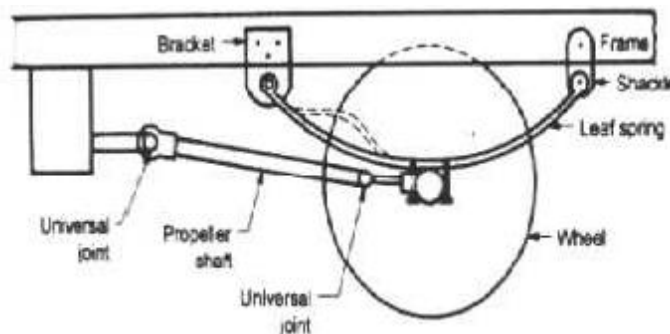

- Hotchkiss drive combines the springing and positioning or locating of the rear axle. It uses a rigid axle with leaf spring mounted at its extremities as far apart as possible on the rear axle.
- The Hotchkiss drive consists of a leaf spring and a propeller shaft with two universal joints and one sliding joint.
- The front end of the leaf spring is pivoted in pin of bracket which is bolted to the vehicle frame.
- While rear end of the leaf spring is supported in swinging shackle with antifriction bush material.
- The leaf springs are bolted rigidly to the rear axle casing at middle.
- The spring takes weight of body, torque reaction and driving thrust.
- The driving and braking torques are absorbed through the front half of the rear leaf spring shown by dotted line.
- During driving and braking, the bevel pinion changes the position so the length and angle of propeller shaft changes which will be adjusted by universal joint and sliding joint. Therefore if only one universal joint is at the front end, then the propeller shaft may bend or damage.
- To avoid this, another universal joint is provided at rear end.
- When the vehicle comes across a bump or shocks, the rear axle moves up and down and it has to move in a circle with front spring supported at the frame as centre.
- During this movement of rear axle, the length of the propeller shaft changes which will be adjusted by sliding joint.

TORQUE TUBE DRIVE:

- In torque drive, the propeller shaft is enclosed in a hollow tube.
- The tube is rigidly bolted to the differential housing at one end and is fastened at the other end to the transmission through a somewhat flexible joint (universal joint) situated in spherical cup fixed to the frame.
- The torque reaction and driving thrust are taken up by torque tube.
- When the vehicle comes across a bump or shocks, the centre line of the bevel pinion shaft will not be shift and always passes through the centre of spherical cup.
- Hence, only one universal joint is required at front end and no universal joint at the rear end.
- The tube incorporates bearing, which support the propeller shaft.
- It is usually located between the (transmission) gear box and the propeller shaft.
- No sliding joint is required in the propeller shaft.

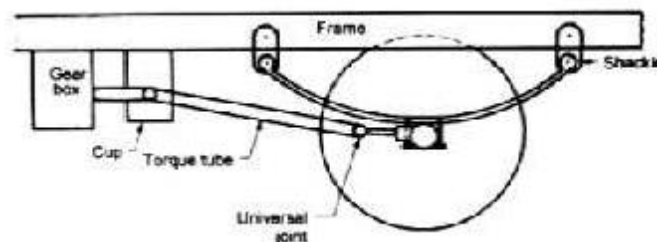

- In many cars a pair of truss rods is attached between the rear axle housing and the transmission end of the torque tube. The torque tube and the truss rod brace the differential housing to prevent excessive differential housing movement.
- In this drive, the leaf springs takes only the side thrust besides supporting weight of the body.

14. EXPLAIN IN DETAIL WITH NEAT SKETCHES ABOUT REAR AXLE CASINGS.

- Split type.
- Banjo or Separate carrier type
- Salisbury or Integral Carrier type.

SPLIT TYPE

- The axle casing is made in two halves and then bolted together for assembly. But the main disadvantage is whole rear axle has to be removed as a unit and reassembled in case of a fault. This kind is no longer used now.

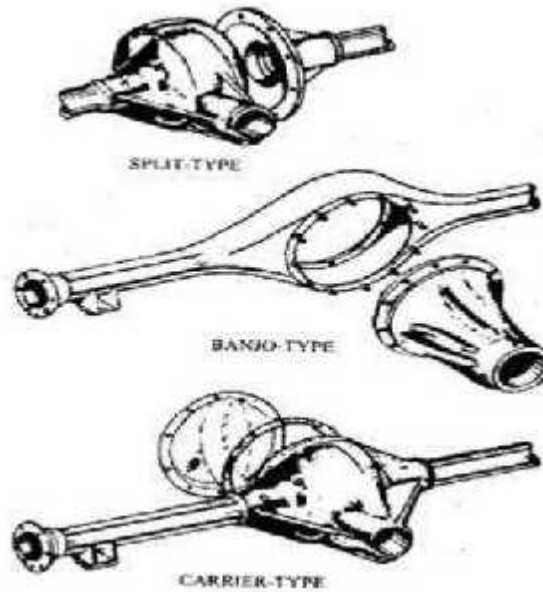

BANJO OR SEPARATE CARRIER

- Axle is made as a single piece. The complete differential unit is a separate unit and is bolted to the axle casing and the two shafts are put from two sides.
- In case of repair, the shafts can be taken from two sides and the differential can be removed easily.

SALISBURY OR INTEGRAL CARRIER TYPE

- This is similar to the banjo type except that the permanent housing tubes are pressed and welded onto the sides.
- This is the most commonly used kind of rear wheel driven cars.

15. EXPLAIN IN DETAIL WITH NEAT SKETCHES ABOUT FINAL DRIVE GEARS.

- Final drive is used to provide a permanent speed reduction and to turn the drive through 90 degrees.
- The reduction ratio provided by the final drive is 4:1 for cars and 10:1 for heavy vehicles.
- The reduction ratio up to 7:1 can be done in a single stage and above that is done in two stages. This is done to reduce the size of the gear and to improve the ground clearance.
- Final drive can be bevel pinion and crown wheel or worm and worm wheel arrangement.

TYPES OF GEARS FOR FINAL DRIVE

- Straight Bevel Gears.
- Spiral Bevel Gears.

- Hypoid Bevel Gears
- Worm and Worm Wheel Arrangement.

1. Straight bevel gears

- The gears have straight teeth.



➤ Advantages

- ✓ Simplest and Cheapest

➤ Disadvantages

- ✓ Uneven transmission due to contact of single pair of teeth.
- ✓ Less load carrying capacity.
- ✓ Noisy and high levels of wear.

2. Spiral bevel gears

- Spiral bevel gears have curved teeth so have greater number of teeth in contact. The gear tooth have sliding motion also in between.



Advantages

- Silent Running.
- They are able to take more loads.

3. Hypoid gears

- The structure of the teeth have hyperboloid in shape. Hyperboloid is obtained by rotating a hyperbola about an offset axis.
- The gears transmit motion at right at right angles but the axis of the gears don't intersect but they lie at an offset distance.



Advantages

- The hypoid gears permit a lower position of the propeller shaft and allow more lower chassis height or less chassis height as the case may be.
- Hypoid gears increases the loads capacity of the gears.

Disadvantage

- Expensive difficult to assemble and need special lubricant due to the greater sliding action between the

4. Worm and worm wheel

- Worm is a single or multi started thread which drives the worm wheel which has teeth over the periphery of the wheel.
- Higher gear ratios are possible in worm and worm wheel arrangement.



Advantages

- Worm and Worm wheel arrangement is particularly used in heavy vehicle where higher gear ratios of greater than 6 needed
- Strong and efficient drive
- Single stage reduction is only necessary for higher gear ratios also.
- Worm gears give low chassis height or more ground clearance as the case may be.

Disadvantages

- Higher cost and more weight than bevel gear
- Mechanical efficiency is lower than bevel gear for single stage reduction
- Lubrication is difficult with overhead worm.

16. WHAT IS DRIVE LINE? WHAT IS PROPELLER SHAFT, UNIVERSAL JOINT AND SLIP JOINT?

- When an engine produces power and clutch and transmission convert it into required torque, some assembly is needed to carry this torque to driving axle or usually to rear axle. This assembly is known as drive line.

- A drive line consist one or more drive shaft (propeller shaft), universal joints, and slip joints. Various types of propeller shaft, universal joint, and slip joints are used to carry engine power from the transmission box to the driving wheels. These are the main components of drive shaft

Propeller shaft:

- The propeller shaft is a driving shaft which connects the transmission main shaft to the differential of the rear axle. It transmits the power from gear box to rear axle with the help of universal joints. The propeller shaft is also known as drive shaft. It performs the following function:

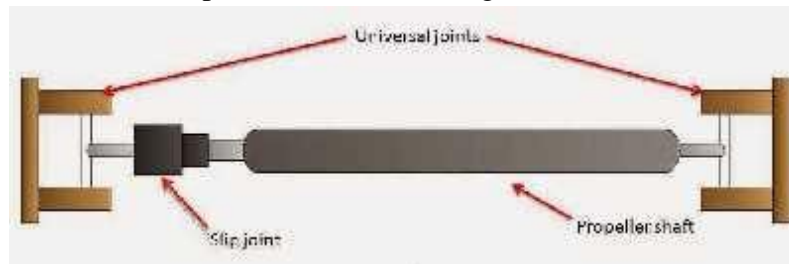

- To receive the power from the gear box output shaft and without any change in speed transmit it to the input pinion of the differential for onward transmission to the rear axle and rear wheels.
- To cope with the difference in line with the level of the gear box output shaft and the differential input pinion shaft. The propeller shaft has to operate at varied lengths and varied angles. The engine of the automobile is somewhat rigidly attached to the frame by springs. As the vehicle moves on the road there are jerks and bumps due to which the springs expand and contract.
- This changes the angle of drive between the propeller shaft and the transmission shaft. The distance between the gear box and differential also changes due to the movement of the springs.
- So the propeller shaft has to meet both the angular change coming between the gear box and differential and change in length of the distance between the gear box and differential.
- The propeller shaft is also not on the same line as the gear box output shaft but it runs to the rear axle at an angle because the level of the rear axle is lower than the gear box. So to adjust angular motion universal joints are provided and to adjust for the change in length of the propeller shaft, a slip joint is provided.
- The propeller shaft has to withstand the torsional stresses of the transmitting torque, and yet it must be light and well balanced so that vibrations will not occur at high speed. So it is usually made of a strong steel tube.

Universal joint:

- A universal joint allows driving torque to be carried through two shafts that are at an angle with each other. A simple universal joint consist two Y- shaped yoke, one on the driving shaft and other on the driven shaft.
- The four arms of spider are assembled in needle bearings in the two yokes. The driving shaft and yoke force the spider to rotate. The other two trunnions of the spider then cause the driven yoke to rotate.
- When the two shafts are at an angle with each other, the needle bearings permit the yokes to swing around on the trunnions with each revolution. A simple universal joint does not transmit the motion uniformly when the shafts are operating an angle.
- Because of this, two universal joints are used in a vehicle, one between the gear box and the propeller shaft and other between the propeller shaft and the differential pinion shaft.

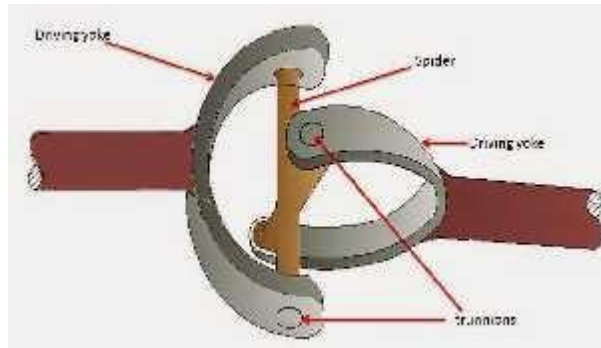

Slip joint:

- Slip joint is attached to the driven yoke in order to increase or decrease the length of propeller shaft. It has outside splines on the shaft and matching internal splines in a mating hollow shaft or yoke. When assembled the splines cause the shafts to rotate together while they can move back and forth. This changes the length of propeller shaft.

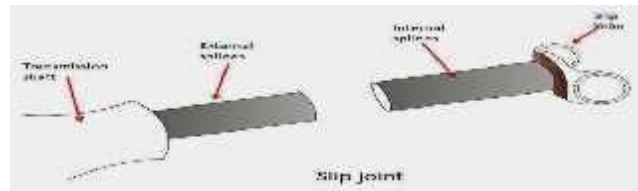

- Today we have learnt about propeller shaft, slip joint and universal joint. If you have any query regarding this article, don't forget to share it on social networks. Subscribe our website for more informative articles. Thanks for reading it.

VARIABLE VELOCITY JOINT

Cross and Roller Universal Joint

- The cross and roller design is the most common type of drive shaft U-joint. It consists of four bearing caps, four needle roller bearings, a cross or journal, grease seals, and snap rings.
- The bearing caps are held stationary in the drive shaft yokes. Roller bearings fit between the caps and the cross to reduce friction. The cross is free to rotate inside the caps and yokes. Snap rings usually fit into grooves cut in the caps or the yoke bores to secure the bearing caps and bearings.
- There are several other methods of securing the bearing caps in the yokes. These are bearing covers, U-bolts, and bearing caps.

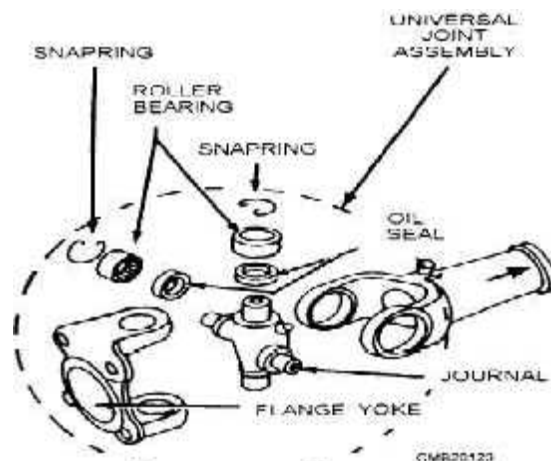

Cross and roller universal joint - disassembled view.

Ball and Trunnion Universal Joint

- The ball and trunnion universal joint is a T-shaped shaft that is enclosed in the body of the joint shown in fig. The trunnion ends are each equipped with a ball, mounted in needle bearings, and move freely in grooves in the outer body of the joint, in effect, creating a slip joint. Compensating springs at each end of the drive shaft hold it in a centered position.
- Variations in length is permitted by the longitudinal movement of the balls in the body grooves. Angular displacement is allowed by outward movement of the balls on the trunnion pins. This type of universal joint is recognized easily by the flexible dust boot that covers it.

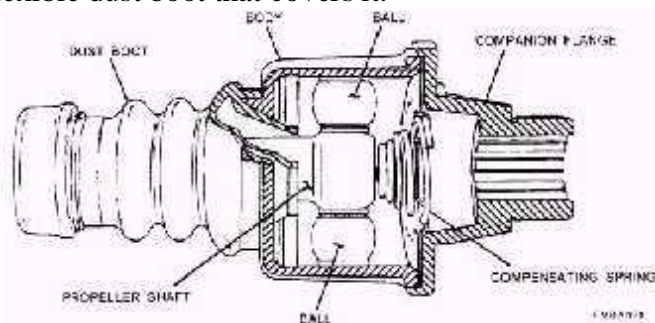

Ball and trunnion universal joint

Double-Cardan Universal Joint

- The double-cardan universal joint uses two cross and roller joints in tandem to form a single joint. The joints are linked through a centering yoke that works in conjunction with a specially designed spring-loaded centering ball. The components are contained within the centering coupling yoke.
- As the shafts rotate, the action of the centering ball and yoke acts to maintain an equally divided drive angle between the connected shafts, resulting in a constant drive velocity.

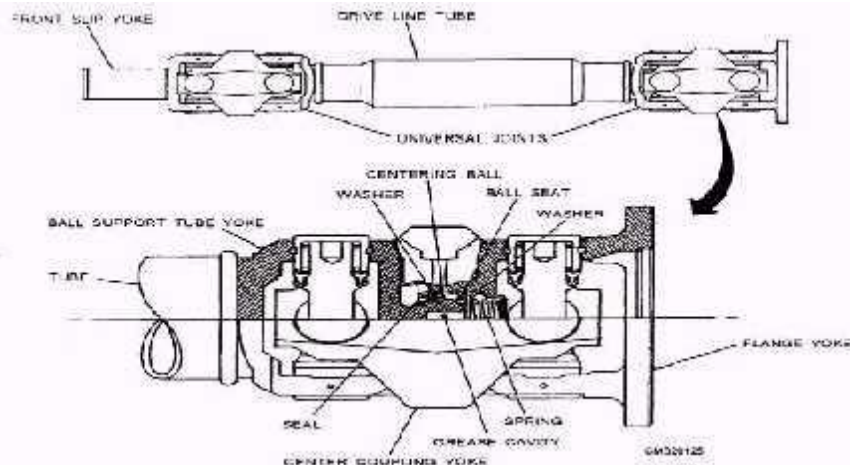

Double-cardan universal joint

CONSTANT VELOCITY (CV) JOINTS

- The speed fluctuations caused by the conventional universal joints do not cause much difficulty in the rear-wheel drive shaft where they have to drive through small angles only. In front-wheel drives, the wheels are cramped up to 30 degrees in steering. For this reason velocity fluctuations present a serious problem.
- Conventional universal joints would cause hard steering, slippage, and tire wear each time the vehicle turns a corner. Constant velocity joints eliminate the pulsations because they are designed to be used exclusively to connect the front axle shaft to the driving wheels.
- Basic operation of a CV joint is as follows: The outboard CV joint is a fixed joint that transfers rotating power from the axle shaft to the hub assembly.

- The inboard CV joint is a sliding joint that functions as a slip joint in a drive shaft for rear-wheel drive vehicles.
- The constant velocity joints you will normally encounter are the Rzeppa, Bendix-Weiss, and tripod types.

Rzeppa Constant Velocity (CV) Joint

- The Rzeppa constant velocity (CV) joint is a ball-bearing type in which the balls furnish the only points of driving contact between the two halves of the coupling. A Rzeppa CV joint consists of a star-shaped inner race, several ball bearings, bearing cage, outer race or housing, and a rubber boot as shown in fig.
- The inner race (driving member) is splined to the inner axle shaft. The outer race (driven member) is a spherical housing that is an integral part of the outer shaft; the balls and ball cage are fitted between the two races.
- The close spherical fit between the three main members supports the inner shaft whenever it is required to slide in the inner race, relieving the balls of any duty other than the transmission of power.
- The movement of the balls is controlled by the ball cage. The ball cage positions the balls in a plane at right angles to the two shafts when the shafts are in the same line. A pilot pin, located in the outer shaft, moves the pilot and the ball cage by simple leverage in such a manner that the angular movement of the cage and balls is one half of the angular movement of the driven shaft.
- For example, when the driven shaft is moved 20 degrees, the cage and balls move 10 degrees. As a result, the balls of the Rzeppa joint are positioned, from the top view, to bisect the angle formed.

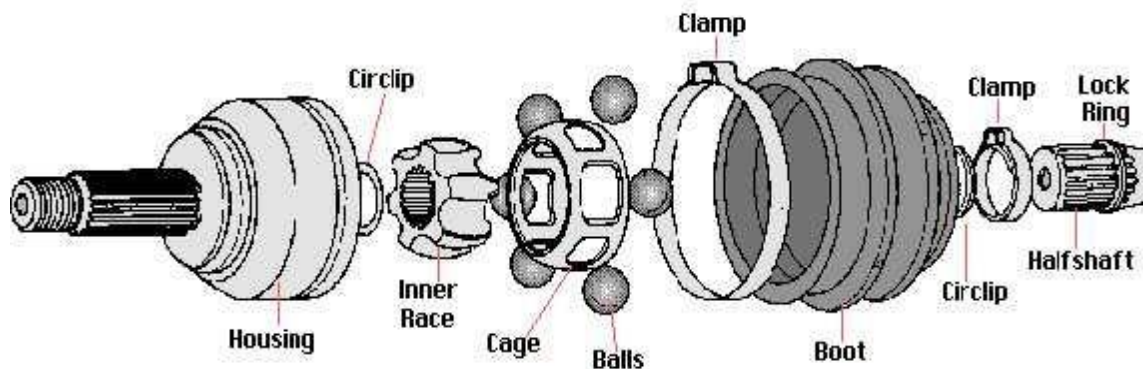

Rzeppa constant velocity (CV) joint.

Bendix-Weiss Constant Velocity (CV) Joint

- The driving contact remains on the plane that bisects the angle between the two shafts; however, it is the rolling friction between the four balls and the
- The Bendix-Weiss constant velocity (CV) joint also uses balls that furnish points of driving contact, but its construction differs from that of the Rzeppa in that the balls are a tight fit between two halves of the coupling and that no cage is used.
- The center ball rotates on a pin inserted in the outer race and serves as a locking medium for the four other balls. Universal joint housing that positions the balls. When both shafts are in line, that is, at an angle of 180 degrees, the balls lie in a plane that is 90 degrees to the shafts.
- If the driving shaft remains in the original position, any movement of the driven shaft will cause the balls to move one half of the angular distance. For example, when the driven shaft moves through an angle of 20 degrees, the angle between the two shafts is reduced to 160 degrees.
- The balls will move 10 degrees in the same direction, and the angle between the driving shaft and the plane in which the balls lie will be reduced to 80 degrees. This action fulfills the requirement that the balls lie in the plane that bisects the angle of drive

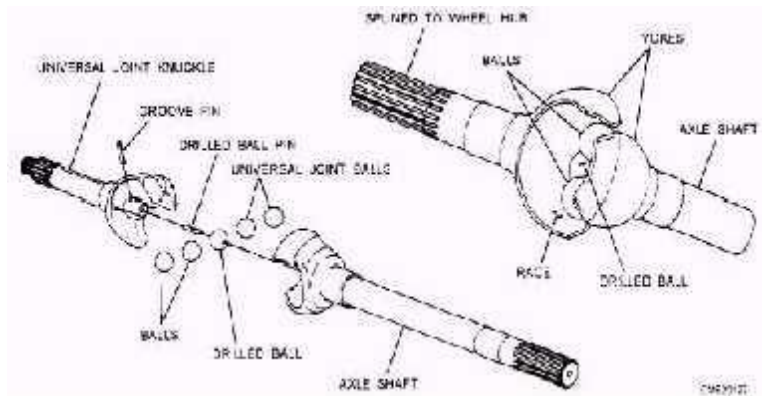

Bendix-Weiss constant velocity (CV) joint

Tripod Joint

- A tripod or ball and housing CV joint consists of a spider, usually three balls, needle bearings, outer yoke, and boot. The inner spider is splined to the axle shaft with the needle bearings and three balls fitting around the spider. The yoke then slides over the balls. Slots in the yoke allow the balls to slide in and out and also swivel.
- During operation, the axle shaft turns the spider and ball assembly. The balls transfer power to the outer housing. Since the outer housing is connected to the axle stub shaft or hub, power is sent through the joint to propel the vehicle.

Cutaway view of Tripod "plunge" style CV joint



17. EXPLAIN THE CONSTRUCTION, WORKING AND APPLICATION OF OVERDRIVE.

- An overdrive is a mechanism that allows an automobile to cruise at sustained speed with reduced engine RPM, leading to better fuel economy, lower noise, and lower wear.
- It is mounted at the rear end of the gearbox.
- The gear ratio provided by an overdrive unit is 30% more than the direct top gear.
- The unit consists of an epicyclic gear train.
- The planet carrier is connected to the output shaft of the gear box.
- When the sun gear is locked to the output shaft of the gear box, the planet carrier rotates about the sun gear.
- The ring gear rotates more slowly than planet gear thus giving more ratio than the direct drive.
- Overdrive is used in some sports cars and luxury cars.
- An Overdrive may be most easily described as an extra, or normally fifth, gear, and although it may technically be used to make a vehicle go faster, that does not realise its correct potential. Indeed, with some cars being equipped with more engine power than stopping ability it may even be dangerous to

misuse it in this way. If an overdrive is used to reduce engine revolutions when cruising speed has been attained in top gear, the benefits are numerous.

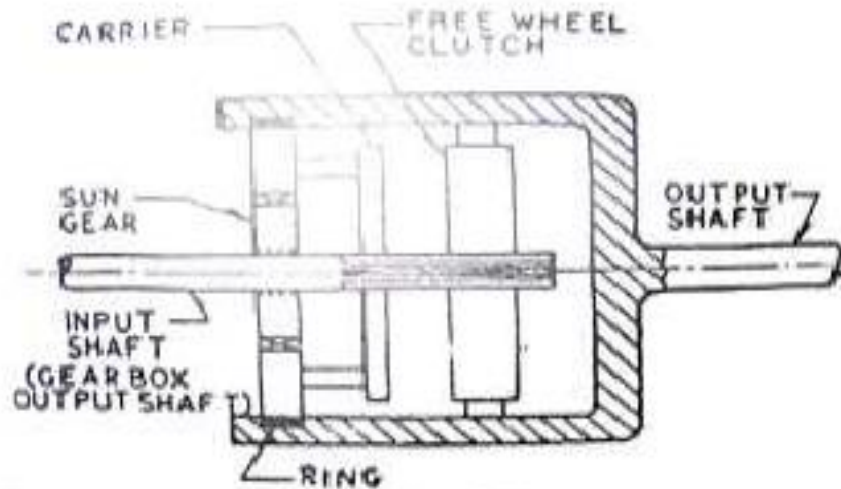

Overdrive

- Probably the most obvious of these is the fuel saving. In normal use this can be expected to be of the order of ten percent, but with care may be pushed up to well in excess of fifteen percent and if the fuel consumption / engine speed graph were linear, a comparative steady speed test should give twenty eight percent saving - but of course life does not consist of linear graphs and steady state conditions!
- A less immediately obvious benefit is the potential engine and transmission wear reduction. As the car travels further, with an overdrive fitted, for the same number of engine revolutions as without, the engine and gearbox must wear out more slowly.
- This not only extends the life of valued components, but puts off the ugly day when a full power train strip down makes inroads into the bank balance.
- The third benefit is even less quantifiable, but is perhaps the most pleasing aspect of using an overdrive. It depends less on theory and calculation and more on the discerning driver and the local County Council. It is not only the cars that have developed over the years, but the roads that they run on are now straighter, less interrupted and smoother, and although even early cars may be capable of a respectable turn of speed, they possibly had little chance of doing so for more than short bursts on most of the roads of their time.
- Today, however, what with junction modifications and the straightening out of bends, even British "B" roads will usually allow a reasonable cruising speed for a reasonable period of time - relatively. The use of an overdrive then allows the engine to relax on the longer straight runs and, hopefully, enhances the pleasure of driving.
- The unit used by Tim Payne Overdrive Designs Ltd is the "Laycock J" or "2XP" type as was manufactured by Laycocks of Coventry, and which is still in production today. This is a well proven design of many years standing and has been fitted to numerous types of vehicle.
- It is an epicyclic gearing arrangement, with a cone clutch either locking the input shaft to the output shaft for direct drive, or locking the centre gear to the case, thereby dictating that the gears on the input shaft rotate not only around their own axis, but also around the inner gear, so forcing the output shaft to rotate faster than the input.

- This is pleasant from an engineering aspect as the loads are distributed within the gear structure, and not via main support bearings as is the case with a conventional fixed centre gear arrangement. A cam is attached to the input shaft and this cam operates a hydraulic pump, the lubricating oil doubling up as the hydraulic power medium.
- When the operating switch makes contact, a solenoid is actuated which moves a valve allowing the hydraulic pressure to engage the cone clutch via a pair of pistons. By the addition of a flanged input shaft and front closing plate the unit is made up into a self contained gearbox, complete with breather, filler, level and drain plugs. The closed unit is then mounted in a carrying cradle and this is suspended on two rubber mounts on a cross bar which clamps to the vehicle chassis. A third supporting point is the drive shaft connecting the overdrive to the gearbox. This shaft includes either a stainless steel flexible coupling, or a single universal or Hooks joint. Both these couplings give excellent axial alignment whilst allowing an element of angular offset, as may be experienced by chassis flex

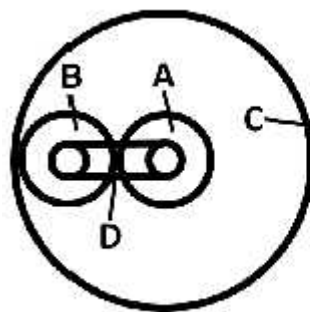

Direct Drive

D is Driver
C is Driven
A is Locked to C

Overdrive

D is Driver
C is Driven
A is Locked Stationary

- This fitting arrangement borrows something from the principle of the three legged stool; it is inherently stable and compact and the mounting points do not run away from their responsibilities by overloading one of their fellows.

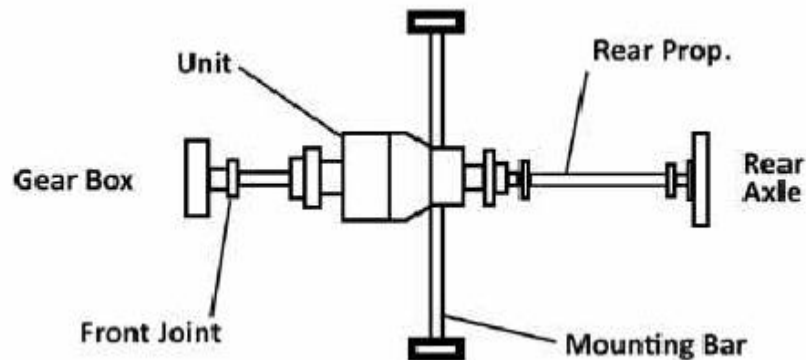

Over drive layout

- Although this was chosen as the most suitable configuration, a thorough understanding of the interaction of the components and some precise machining is required to ensure the assembly of a unit which is smooth and reliable. A conventional prop. shaft then runs from the rear of the overdrive to the rear axle of the car. To allow the speedometer to work correctly in all gears including overdrive, the speedometer drive at the rear of the unit is used, and attached to the existing cable via an adaptor box.
- The adaptor box is calibrated to also take into account any variations in tyre size or axle ratio and can allow for any calibration drift which may have crept into the speedometer instrument over time.
- The main criteria for fitting an overdrive are that there is sufficient room under the car, and that there is a minimum of 38" of prop. shaft. Having said that, development is under way for a system for use on the

Torque tube Silver Ghost and Phantom I cars. The same principle is used, but with the overdrive mounted inside a "Torque Box" which replaces the front half of the Torque tube.

- It is a policy to avoid, as far as possible, altering the vehicle components, so allowing the car to be easily returned to original condition with no evidence that it had been "tampered with". With the 3 1/2 and 4 1/4 Derby models it is necessary to drill a hole for mounting an interlock switch near the gear lever, but this would never be done without the approval of the customer. Certainly cutting prop. shafts, welding brackets onto the chassis and modifying the bodywork are definitely not considered to be options. Only high quality components are used and, as far as possible, parts are nickel plated or powder coat painted.

1. DISCUSS IN DETAIL ABOUT THE DIFFERENT TYPES OF WHEELS AND TIRES WITH RESPECT TO CONSTRUCTION, ADVANTAGES AND DISADVANTAGES.

WHEELS

- Wheels can be defined as “a disc or spoke with hub (revolving around axle) at centre & has a rim around the outside of disc for mounting the tyre”.

Necessity of wheel's

- Wheel must sustain vehicle & passenger load.
- It provides cushioning effect & copes with steering control.

Requirement of wheel's

- It should be light in weight
- It should be possible to remove or mount the wheel easily.
- It must be balanced both statically & dynamically.
- Wheels material should not deteriorate. It must have better corrosion resistance.
- It should have good load carrying capacity; it must resist bending, tensile, compressive & torsional stresses.
- Cushioning effect is necessary to absorb shock load (due to road irregularities) & damp the vibration faster.

Type's of wheels

- There are three types of wheels, namely
 - ❖ Pressed steel disc
 - ❖ wheel Wire wheel
 - ❖ Light alloy cast or forged wheel.



Pressed Steel Disc Wheel:

- Presses steel disc wheels consist of two parts,
 - ❖ Steel rim
 - ❖ Pressed steel disc

Construction of pressed disc wheel is as below

- The rim & disc may be integral, permanently attached or attachable (above figure shows disc welded to rim).
- The rim has a well, which allows the tyre to go over the edge of opposite side of rim.
- A 5° taper is given at edge of rim on which tyre seats.

➤ Pressed steel disc performs function of spokes.

- Ventilation slots are provided on disc for better cooling of brake drums.
- Holes are provided on pressed disc & rim for mounting of wheel & air valve resp.

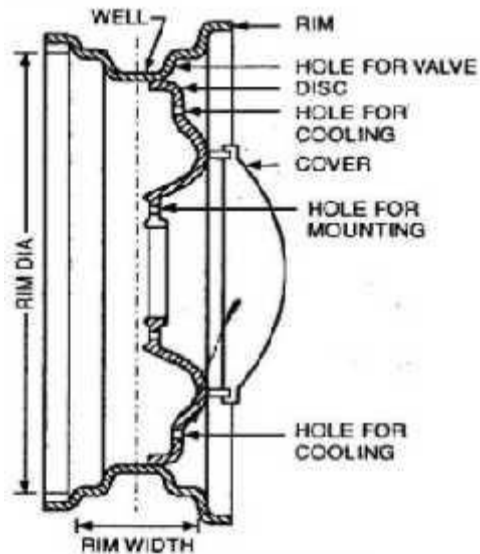

Disc wheel

Features

- Pressed disc wheel are simple in design
- These wheels are robust in design.
- These wheels have economical prices.
- Better cooling is possible in this type of wheels.

Application

- These wheels are used in heavy motor vehicle (tuck,tractor's etc.) & car's.

Wire Wheel

- Wire Wheels have Separate hub, which is attached to rim through no. of wires pokes.
- Various components of wire wheels are as follows:

- ❖ Spoke
- ❖ Hub
- ❖ Rim

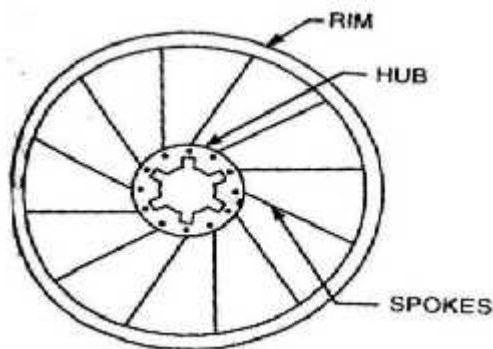

Wire wheel

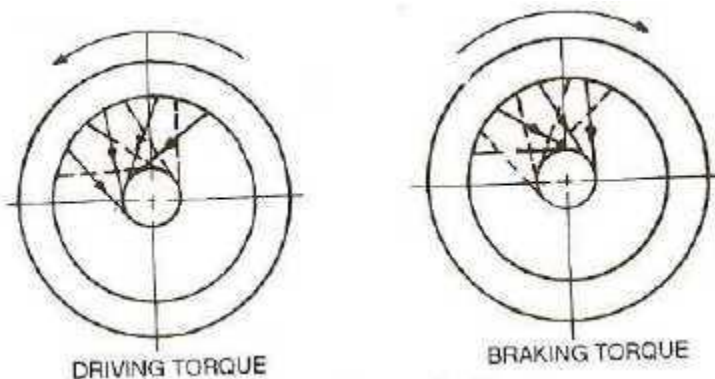

Arrangement of spokes

Spokes

- Spoke's one end of spoke is hooked to hub while other end is attached to wheel rim
- Spoke carries vehicles & passengers weight. It transmits driving & breaking torque & withstands side forces while cornering (i.e :-cornering load & side thrust)

Hub

- Hub is provided with internal splines & is mounted on the axle shaft.
- One end of spoke is hooked to hub end.

Rim

- Rim has holes at the centre for attaching spokes.
- The only disadvantage of this rims are, tubeless tyre cannot be mounted on it because of holes on the rim.

Advantages of wire wheels

- Wire wheels are light in weight
- Wire wheels provide better cooling of brake drum.
- They have high strength.
- They have better change ability as only 1 nut needs to be opened for mounting & dismounting of wheel.

Application:-

- 2 wheelers & bicycles

Light Alloy Cast or Forged wheel

- Automobile is use of wheel made from Aluminum & magnesium alloy. These wheels are lighter than steel wheels.

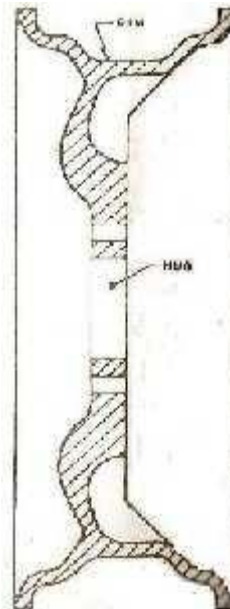

Light alloy wheel

Advantages

- Light alloy wheels are better conductor of heat, which helps to dissipate heat generated by braking.
- Wider rims are possible in this wheels which improves stability on cornering
- Castor forged wheels need to be machined yet it helps to maintain close tolerance.
- These wheels are lighter as compared to steel wheels.

- Magnesium alloy have high impact & fatigue strength, so they can stand vibration & shock loads.
- Aluminum alloy are easier to cast or forged & are less prone to corrosion.

Disadvantage

- The only disadvantage of this wheel is, they have highly priced.

Application

- Cast wheels are used in cars & Forged wheels are used in heavy duty vehicles.



Rims

Necessity

- Rim is outer circular part of wheel on which tyre is mounted & supported.
- Types of rims are as follows
 - ❖ Well base rim
 - ❖ Flat base rim
 - ❖ Semi drop centre rim.
 - ❖ Flat base divided rim

Wheel base rim

- This type of rim is used for passenger car tyres. The well enables tyre to pass over the edge of opposite side of rim.
- The tyre gets locked to rim on inflation, a slight taper (5°) is provided for this purpose.

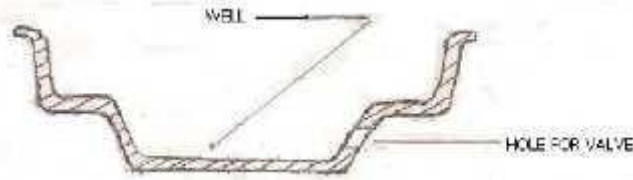

Wheel base rim

Flat base rim

- The flange at one end is held in position by pushing by pushing the flanges inward. This tyre can be mounted & removed easily.
- Flat based rim are used in tyres of heavy duty vehicles.



Flat base rim

Semi drop centre rim

- This type of rim is used in light commercial vehicles. It gives advantage of both well base & flat base rim.
- The detachable flange makes tyre removal easy, while light taper helps the tyre lock on rim.

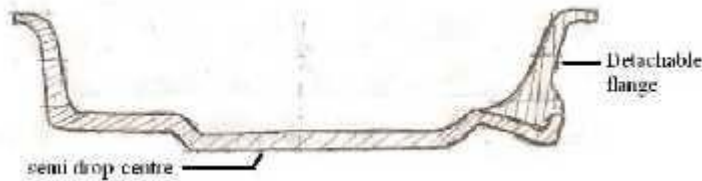

Semi drop centre rim

Flat base divided rim

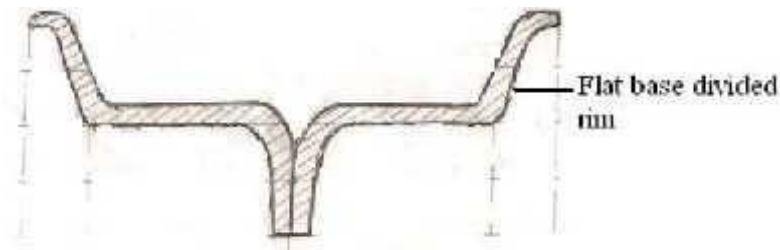

Flat base divided rim

- Flat base divided rims are in two sections, which are bolted together. These rims are used in military & heavy duty applications

TYRES

- Tyre is a cushion provided with an automobile wheel. It consists of an outer cover (i.e.: -tyre proper) which has a tube inside. This tyre tube is mounted on the wheel rim.

Necessity of tyre

- Tyre reduces road shocks & provides a cushioning effect.
- Tyre is responsible for improved traction (i.e.: -better friction between tyre & road surface)

Properties of tyre or Requirement of tyre

Requirement of tyre's are as follows.

- **Load carrying capacity:**-Tyre should be able to carry weight of vehicle & passenger without distortion. Tyre must resist bending, tensile, compressive & torsional stresses.
- **Cushioning:**-Tyre should absorb shock loads caused due to due road irregularities & damp the vibration faster.
- **Uniform wear:**-Uniform wear reduces tyre skidding & vibration due to road irregularities.
- **Non-Skidding:**-Tread pattern must be such that tyre must not skid. The tyre must have high coefficient of friction
- **Power consumption:**-Tyre must have low rolling resistance & therefore must consume least power of engine.
- **Noise:**-Tyre noise must be minimum. It depends on tread pattern & type of road.
- **Balance:**-The tyre must be statically & dynamically balanced or it may cause wheel wobbling.

Apart from above properties a tyre must provide better durability, good abrasive resistance, safety & have low cost.

Types of tyres

- Pneumatic tyres are of 2 types
 - ❖ Conventional tube tyre
 - ❖ Tubeless tyre

Conventional tube tyre

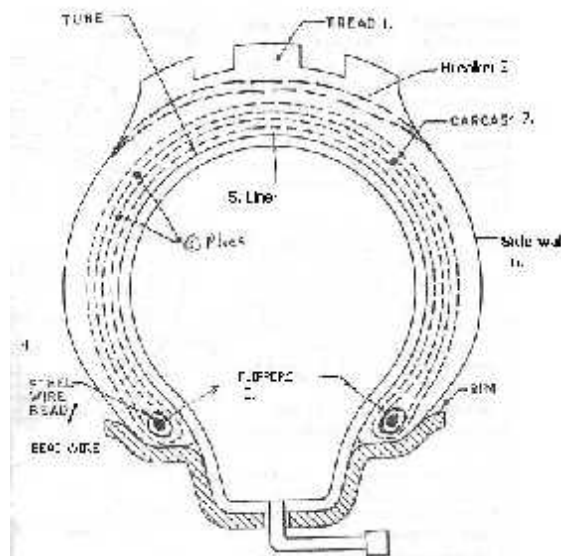

Conventional tyre with tube

Tread

- The shoulder to shoulder portion of tyre that comes in contact with road surface is known as tread.
- Its primary function is to transmit driving & breaking torque. Tread are bonded on carcass & material used are natural or synthetic rubber.

Breakers

- Top two plies of tyre are known as breakers. This plies are widely spaced to help in spreading the shocks from road & to prevent radial growth of tyre during inflation.

Carcass/Casing

- Carcass is made up of layers of cord impregnated with rubber. The number of layers of cord varies according to the use of tyre (carcass have 4-6 plies, heavy duty vehicles have 22 plies).
- Carcass bears shock load, side thrust & vehicle's weight.

Flippers

- A number of layers of additional cords are wound around bead wired for extra strength & avoid stress concentration.
- Flippers are wound up to small distance on the side wall.

Sidewall

- It serves as protective covering to carcass, but it is subjected to maximum flexing action, creating large amount of heat building.

Beads

- Coil of wires represent the bead. A number of highly tensile steel wires which are built in the edge of tyre in order to give strong edges to press against the inner edge of the rim.
- This plies of cord are fastened to them & therefore serve as metal foundation of tyre.

Tubeless tyre

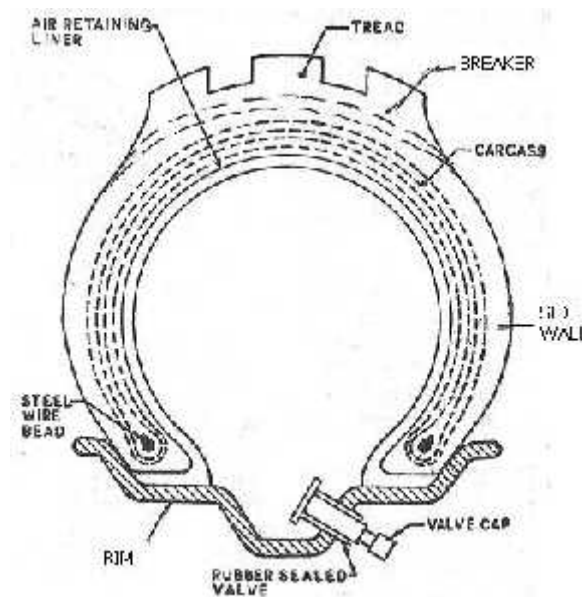

Section of Tubeless tyre

Construction

- The material & design of carcass & tread remains similar to tubed type tyre.
- The inside of casing is lined with soft rubber lining which forms an air tight seal with rim, it is known as "air-retainer liner". This lining retains the air & seals itself on being punctured.
- A "non return valve" is fitted to rim through which the air is forced inside the tyre.

Advantages

- Temporary puncture repairs are made without removing the wheel. A rubber plug is inserted at place of puncture.
- Tyre deflates slowly; air is retained for longer period even after being punctured.
- Tubeless tyres are lighter in weight & run cooler than tubeless tyre.
- Tubeless tyre imparts more resistance to impact load.

- Better air sealing qualities are obtained.
- It has simpler assembly, only tyre has to be fitted over rim (no tube).

Disadvantages

- The only disadvantage of this type of tyre is, its unsuitable for spoked & corroded wheel's.

Tyre material

- Basic constitute of tyre are as follows
 - ❖ Rubber-natural or synthetic.
 - ❖ Cord of stabilizer belt.
 - ❖ Steel for high tensile steel bead wires.
- **Rubber-natural or synthetic**
 - ❖ **Natural rubber**:-It was used to impregnate the carcass cotton cords.
 - ❖ **Styrene butadiene rubber (SBR)**:-SBR was used to impregnate on nylon cords. It provides better road grip, better abrasive resistance & smooth ride.
 - ❖ **Poly butadiene (PB)**:-PB is mixed with SBR & additives like carbon black, oil & sulphur imparts anti wear, anti-skid & anti heat properties.
- **Cord of stabilizer belt**: The material used is rayon, Terylene, glass fibre or steel. Steel is commonly used in case of radial tyre belt.
- **Steel for high tensile steel bead wires**: Bronze plated highly tensile steel wire is used, on which special rubber is insulated. Above given are material used for various tyre component.

Carcass

- Carcass is main structure of wire which takes stresses while operation & tyre is named on the basis of carcass used.
- There are three types of carcass
 - ❖ Cross ply type
 - ❖ Radial ply type
 - ❖ Belted bias type

Cross ply or bias ply type:

- In this type, the ply cord are woven at an angle (30-40°) to tyre axis.
- There are 2 layers which run in opp. direction as shown in figure.
- This construction allows carcass to retain its strength during tyre rotation provides comfortable ride.
- Thus carcass is able to resist stresses caused due to sudden acceleration, Cornering & breaking.

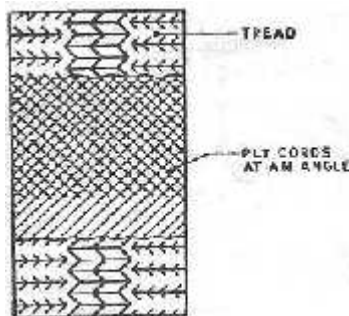

Cross ply or bias ply type

Radial ply type

- In this structure ply cords run in radial direction (i.e.: in direction of the tyre axis)

- Over this basic structure run a number of breaker strips in circumferential direction. The material for breaker strip must be flexible but inextensible so that no change of circumference takes place with change in amount of inflation.
- Breakers are widely spaced to help in spreading shocks from road & prevent radial growth.
- The inextensible breaker strips provides lateral & directional stability.

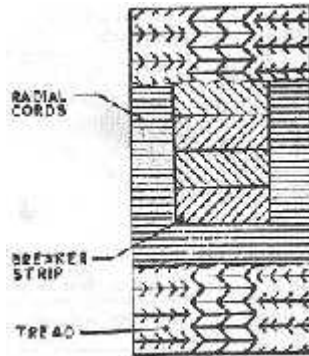

Radial ply type

Belted bias type

- This is a combination of cross ply & radial ply structure.
- The basic structure is cross ply over which run a number of breaker belts. This belt improves characteristics of bias ply tyre to a large extent.

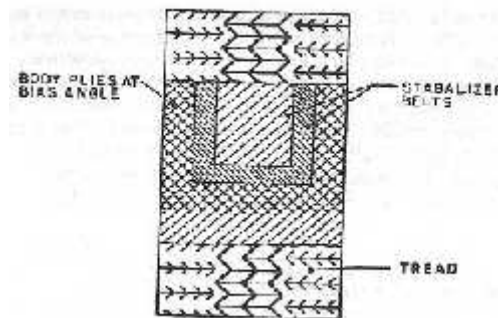

Belted bias tyre

Feature of belted bias tyre

- The stresses in carcass are restricted & tread area is stabilized due to belts. This increases tire life.
- Breaker belt holds the tread flatter against road surface & provides safe ride.
- Belt increases resistance of tyre for cuts & punctures.

Advantage

- Treads of radial ply offers better stiffness & resistance resulting in better grip.
- Radial ply have longer tread life.
- Radial ply provide better breaking grip.
- Radial ply have better steering characteristics as compared to cross ply.

Comparison between Radial ply & Cross ply

S.No	Radial ply tyre	Cross ply tyre
1	In radial ply type, the cords of tyre run in radial direction	In cross ply type, alternate layers of cords run in opposite direction
2	The cord ply are woven in radial direction of tyre	The cord ply are woven at angle(30-40°)to the

	axis	tyre axis
3	Radial tyre are provided with breaker strip, thus a continuous flat contact is possible with road surface	There is no breaker strip in this tyre. Thus continuous grip with road surface is not possible
4	This tyre has low rolling resistance, thus better fuel efficiency	The cross ply has more rolling resistance as compared to cross ply
5	This tyre provides better directional stability	This tyre has wobbling characteristics
6	This tyre has greater sidewall flexibility & treads stiffness	Sidewall flexibility & tread stiffness is lesser as compared to radial ply tyre.

Tread

➤ Tread can be defined as “Shoulder to Shoulder width of the tyre that comes in contact with the road surface”.

Necessity of treads

- It improves tyre ability to transmit driving & breaking torque.
- It provides stability & non skidding characteristic to tyre.

Straight tread: It provides better adhesion, good grip & better steering stability.

Cross tread: It provides better grip but it has rapid, irregular wear & noisy running

Square tread - It provides straight & sideways grip but it has irregular wear on hard road has noisy running

Combination tread- It is combination of cross & straight pattern. It has good wear resistance & steering characteristics. Application-trailer & farming application.

V patter – Deep groove pattern – these tyre are used on rough & loose surface, giving maximum grip & sideways stability.

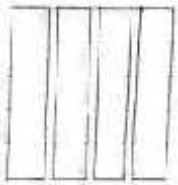

Straight tread



cross tread

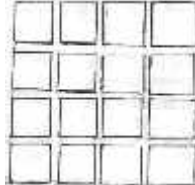

square tread

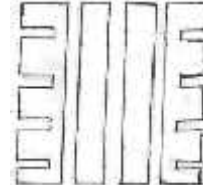

combination tread

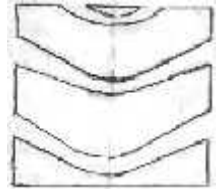

V patter tread

Application-Tractor's rear wheel.

Tyre Inflation

- The inflation pressure is recommended by the vehicle manufacturer depending upon tyre size, speed & load.
- **Under inflation causes the following defects**
 - ❖ Uneven tread wear, more wear at tyre sides.
 - ❖ Lack of directional stability.
 - ❖ Increased rolling resistance leading to increased fuel consumption.
 - ❖ Excessive flexing of sidewall causes build up.
 - ❖ The valve may be ripped out due to tyre punch.
- **Over inflation causes the following defect**
 - ❖ Reduced tread contact area with road surface.
 - ❖ Reduced tyre grip.
 - ❖ Reduced impact resistance.
 - ❖ Increased vibration resulting in uncomfortable ride.
 - ❖ Increased stresses may causes tread separation & crack in the sidewall

2. WITH NEAT SKETCH EXPLAIN THE VARIOUS PARTS IN A FRONT AXLE ASSEMBLY.(OR) EXPLAIN THE DIFFERENT TYPES OF STUB AXLE WITH NEAT SKETCH.

- Front axle carries the weight of the front part of the automobile as well as facilitates steering and absorbs shocks due to road surface variations.
- The front axles are generally **dead axles**, but are **live axles** in small cars of compact designs and also in case of four-wheel drive.
- The front axle is designed to transmit the weight of the automobile from the springs to the front wheels, turning right or left as required.
- To prevent interference due to front engine location, and for providing greater stability and safety at high speeds by lowering the centre of gravity of the road vehicles, the entire centre portion of the axle is dropped.
- A **live front axle** contains the differential mechanism through which the engine power flows towards the front wheels.
- For steering the front wheels, constant velocity joints are contained in the axle half shafts.
- Without affecting the power flow through the half shafts, these joints help in turning the stub axles around the king-pin.

Front wheels of the vehicle are mounted on front axles.

- It supports the weight of front part of the vehicle.
- It facilitates steering.
- It absorbs shocks which are transmitted due to road surface irregularities.
- It absorbs torque applied on it due to braking of vehicle.

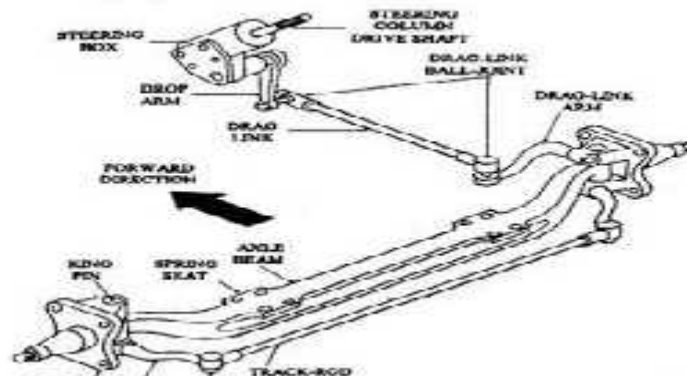

Front Axle

AXLE

- Axles are also an essential component of an automobile. There are two types of axles: The one which transmits power to the wheel is known as live axle and the one which does not transfer any power and acts like a beam is known as a dead axle
- Axles are an important component of a car. All cars have two main axles in it: front axle and dead axle. Apart from this, there is a stub axle which is not found in every car. Axles are a kind of shaft which freely rotates on its desired axes, the axes connecting centers of opposite side of wheels. Axles are used to rotate the wheels of a car. Sometimes, other mechanical components are also mounted on axles.

DEAD AXLE

- Dead axles are those axles, which do not rotate
- These axles have sufficient rigidity and strength to take the weight.

- The ends of front axle are suitably designed to accommodate stub axles.



LIVE AXLE

- Live axle transmits power to wheels coming from the differential. Or a mechanical engineer will call it a 'prime mover'.
- The live axle is in a two half axles both of which are combined with a differential using the universal joint. Each half of a joint is connected to its corresponding wheels using constant velocity joint (CV). The role of CV joint is to facilitate vertical as well as pivot motions of a wheel assembly.



STUB AXLE

- The front wheels are mounted on the stub axle, which are connected to the front axle by means of king pin. The stub axles are the forging of 3 per cent nickel steel and alloy steels containing chromium and vanadium.
- The stub axle turns on the pin which is a light drive fit in the axle beam eye located and locked by a taper pin or some similar arrangement.

TYPES OF STUB AXLES

- Elliot
- Reversed Elliot (Most commonly used)
- Lamoine
- Reversed lamonine

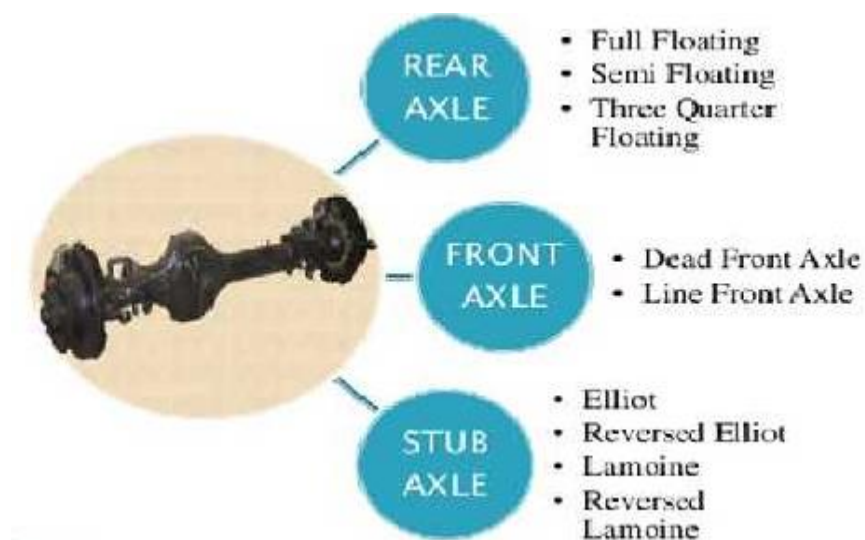

Types of axles

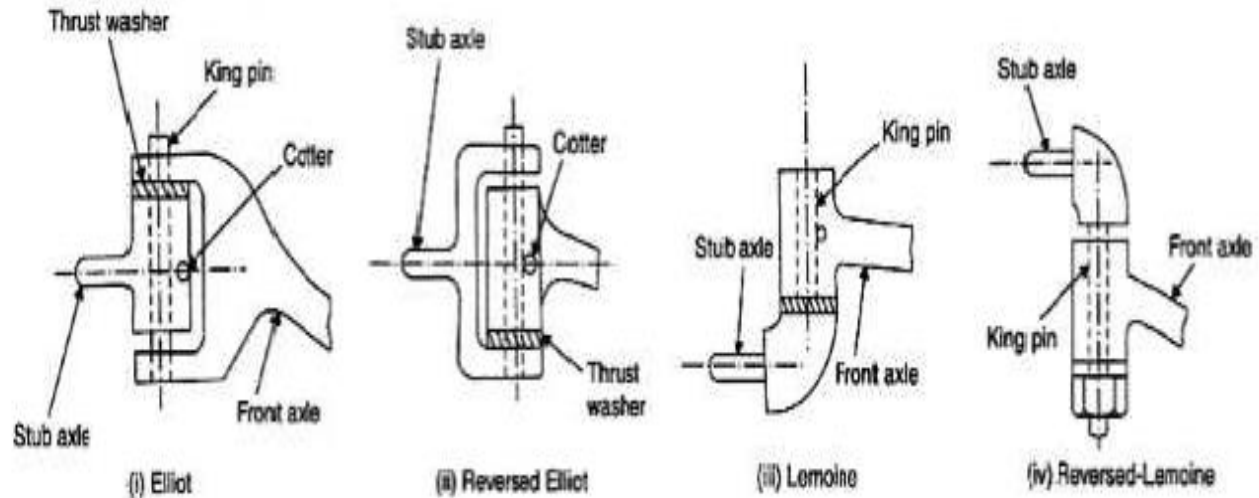

Types of stub axle

Elliot stub axles

- In this type the axle is a single rigid 'I' shaped beam with a provision to fit the stub axle at its two ends. The end of the axle is Elliot shaped (U-shaped) with two eyes.
- The stub axle is mounted in between the two eyes with a thrust bearing at the top end of the stub axle

Reversed Elliot stub axle

- In reversed elliot type stub axle the arrangement is reversed. The axle beam is mounted in between the two eyes of the stub axle with a thrust washer at the bottom of the axle.
- It is commonly used in vehicle because of the following reasons.
 - ❖ It is easier to manufacture
 - ❖ Load exerted by the stub axle is equally distributed
 - ❖ Due to equally distributed load steering load steering is easy.

Lemoine type stub axle

- In this type, instead of a yoke type hinge, an L-shaped. Spindle is attached to the end of the axle by means of a pivot.
- The stub axle is mounted on the bottom of the axle beam. It is used in tractors.

Reversed Lemoine type stub axle

- In this type of stub axle, the arrangement is reversed. Hence the stub axle is mounted on the top of the axle beam

Front Axle Construction

- The axle beam in use is of I or H-section and is manufactured from alloy forged steel for rigidity and strength.
- As compared to dead front axles, a totally different type of swiveling mechanism is used on the live front axle.
- To connect the wheel hub axles with driving axle shafts, constant velocity joints are used for the vehicles fitted with the front live axles.
- Tracta, Rzeppa (or Sheppa) on Bendix constant velocity or universal joints are normally used.

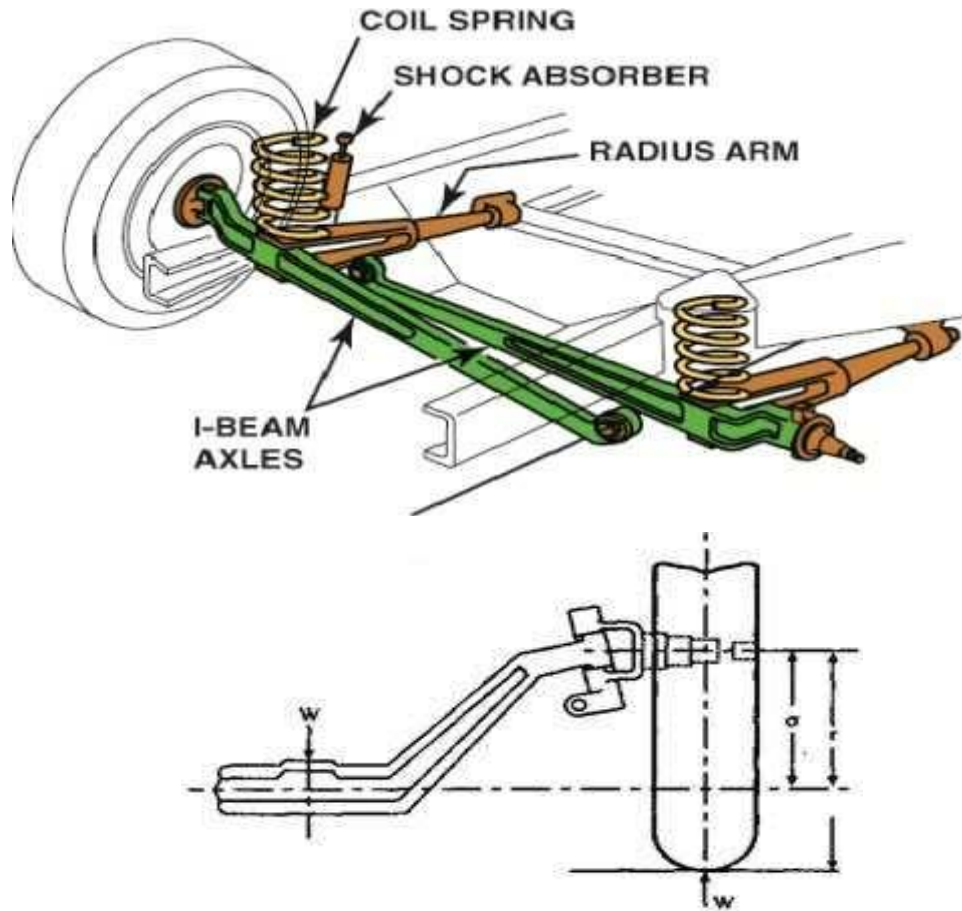

Loading

- Front axles are subjected to both bending and shear stresses.
- In the static condition, the axle may be considered as a beam supported vertically upward at the ends i.e. at the centre of the wheels and loaded vertically downward at the centres of the spring pads.
- The vertical bending moment thus caused is zero at the point of support and rises linearly to a maximum at the point of loading and then remains constant.
- Thus the maximum bending moment = Wl , Nm

Where, W = The load on one wheel, N

l = the distance between the centre of wheel and the spring pad, m

3. EXPLAIN THE WHEEL ALIGNMENT, FACTORS OF WHEEL ALIGNMENT AND FACTORS PERTAINING TO WHEELS WITH NEAT SKETCH.

WHEEL ALIGNMENT

Position of the steered wheels to achieve the following is termed wheel alignment

- Directional stability during straight ahead position
- Perfect rolling condition on steering
- Recovery after completing the turn

There different types of alignment

- The front-end alignment
- Thrust angle alignment
- Four – wheel alignment
 - ❖ During the front wheel alignment, only front axle angles are measured and adjusted.

- ❖ This type of alignment is alright for vehicle having a solid rear axle, but confirming that the rear are positioned directly behind the front tyres is also important, which is done with thrust angle alignment.
- ❖ However , all vehicle do not have fully adjustable parameter, some vehicle require after market kits to allow sufficient adjustment to compensate for accident damage or for change in alignment due to the installation of lower springs.
- ❖ It also has to be remembered that the alignment has tp be done only when the vehicle carries the specified

Thrust angle alignment

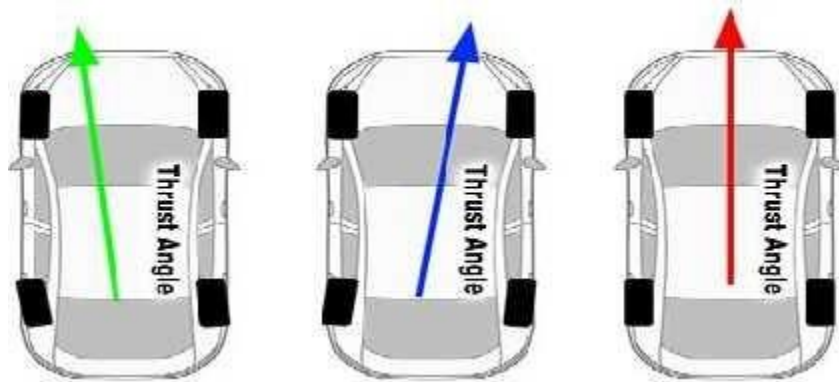

Four – wheel alignment

- In the panel above, the red line represents the thrust angle, which should run at a right angle through the length of the car relative to the centre line of the rear axle, and if this setting is correct, the front wheels are aligned to this line.
- However, if the center line of the rear axle is not at right angles with the thrust line, the misaligned rear axle (as shown by the green and blue lines) will force the rear wheels not to follow the front wheels, and continual counter steering is required to keep the vehicle moving in a straight line. Thrust line adjustment therefore involves realigning the rear axle with the thrust line to ensure that the rear wheels run in the same line as the front wheels without the need to apply a corrective steering input.
- The image above shows all the adjustments required to ensure that all the wheels on a vehicle are properly aligned to each other, as well as to the centerline of the vehicle, which is commonly referred to as the “thrust line”.
- Although this type of procedure is most commonly performed on powerful high-end sports cars to ensure that the car’s handling characteristics are not compromised, many “ordinary” cars can benefit greatly from this procedure as well. If the procedure is performed by a suitably qualified technician, this procedure produces the best results in terms of alignment accuracy.

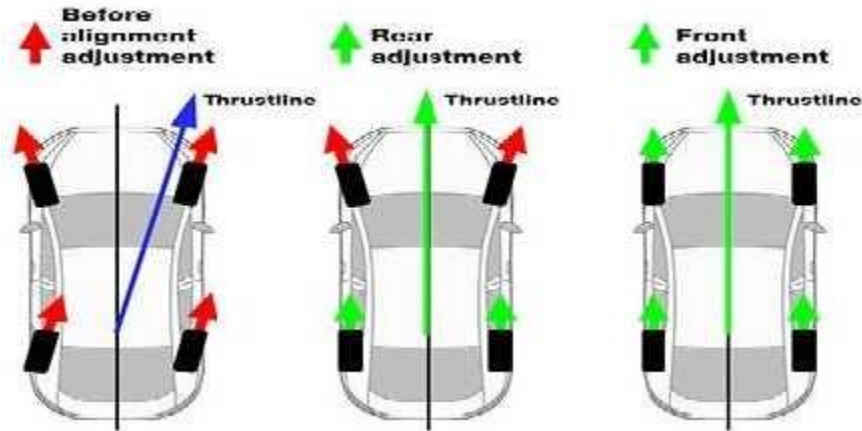

Factors of Wheel Alignment

- Wheel alignment, sometimes referred to as breaking or tracking, is part of standard [automobile maintenance](#) that consists of adjusting the angles of wheels to the car manufacturer specifications.
- The purpose of these adjustments is to reduce [tire](#) wear, and to ensure that vehicle travel is straight and true (without "pulling" to one side). Alignment angles can also be altered beyond the maker's specifications to obtain a specific handling characteristic.
- Motorsport and off-road applications may call for angles to be adjusted well beyond "normal", for a variety of reasons.
- An increasing number of modern vehicles have advanced driver assistance systems (ADAS) such as electronic stability control, anti-lock brakes, lane departure warning, adaptive cruise control and traction control. These systems can be affected by mechanical alignment adjustments. This has led many manufacturers to require electronic resets for these systems after a mechanical alignment is performed
 - ❖ Toe-in and toe-out
 - ❖ Good steering, handling and vehicle, it is also necessary
 - ✓ set back (the distance b/w placing of the front tyres)
 - ✓ the thrust angle
 - ❖ Factors pertaining to wheels
 - ❖ Steering geometry
 - ❖ Steering linkage
 - ❖ Suspension system
- **Toe-In:** It is the amount by which front wheels are set closer together in front than at the rear when viewed from the top. It is done so that wheels move perfectly straight under normal condition. It does not exceed 3 mm.
- **Toe-Out:** It is the amount by which front wheels are set apart in front than at the rear when viewed from the top. Initially done in **front wheel drive** to avoid tendency to toe-in. It is the inherent tendency in **rear wheel drive**.
- **Setback:** - Set *back* is defined, where one of the front wheels is sitting *back* (relative to the wheel on the other side). Front setback is a measurement referencing the front wheels to a line placed perpendicular to the vehicle centerline. ... Positive setback indicates that the right front wheel is setback further than the left. Negative setback refers to the left front wheel being further back than the right.

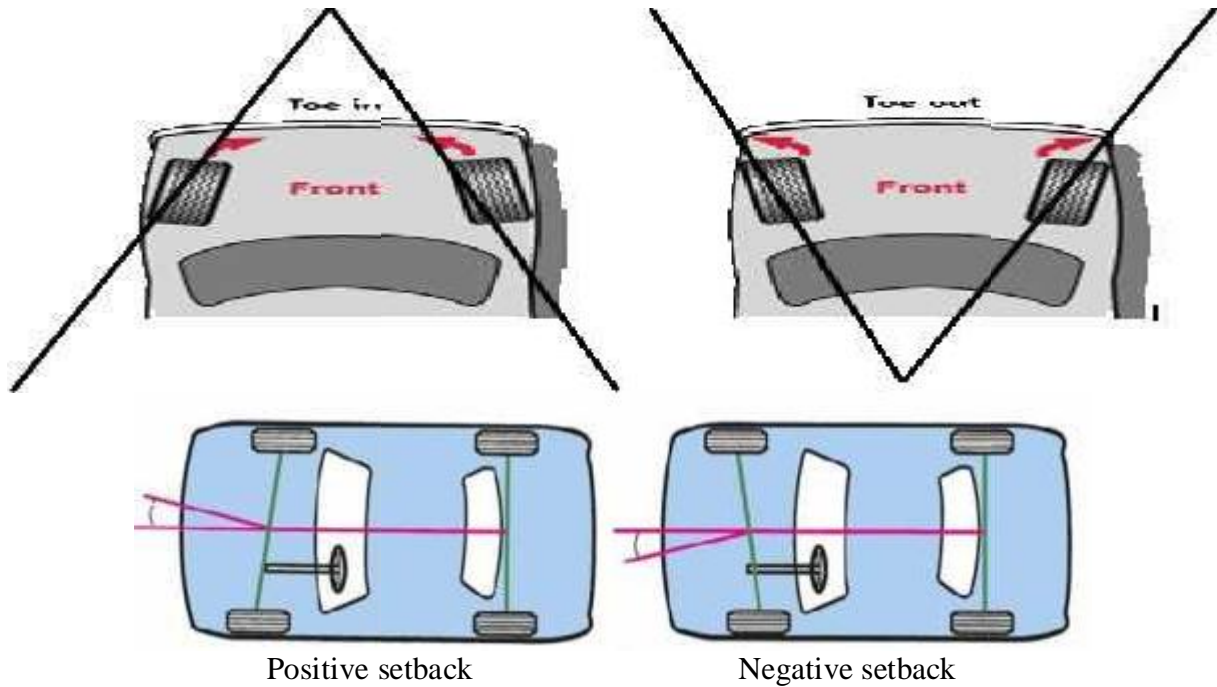

Thrust Angle

- The thrust angle is an imaginary line drawn perpendicular to the rear axle's centerline. It compares the direction that the rear axle is aimed with the centerline of the vehicle. It also confirms if the rear axle is parallel to its front axle and that the wheelbase on both sides of the vehicle is the same.
- If the thrust angle is not correct on a vehicle with a solid rear axle, it often requires a trip to the frame straightening shop to correctly reposition the rear axle.
- A vehicle with independent rear axles may have incorrect toe-in or toe-out on both sides of the axle, or may have toe-in on one side and toe-out on the other. The suspension on each side of the vehicle must be adjusted individually until it has reached the appropriate toe setting for its side of the vehicle.
- An incorrect thrust angle is often caused by an out-of-position axle or incorrect toe settings. So in addition to the handling quirks that are the result of incorrect toe settings, thrust angles can also cause the vehicle to handle differently when turning one direction vs. the other

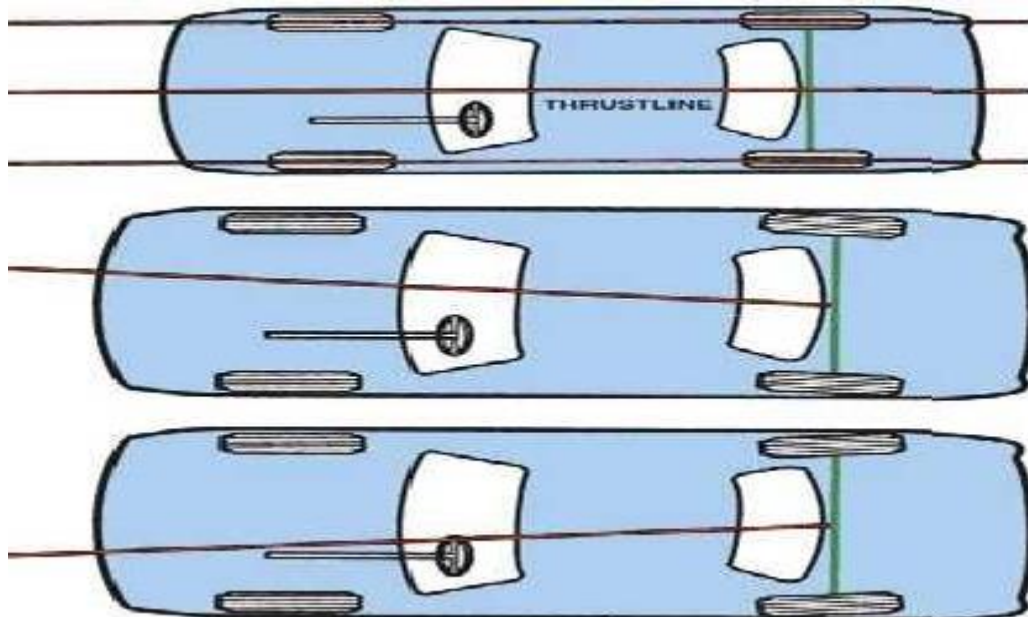

Factors Pertaining To Wheels

Balance of wheels - If the wheels are not in dynamic balance, the wheel wobble may result, which influences steering control.

Inflation of tyres – the steering system is designed for a particular rolling radius. Variation of air pressure from the standard prescribed will change the rolling radius.

Brake adjustment - If the brake is not adjusted properly, it can pull the vehicle to one while braking.

4. SKETCH AND EXPLAIN VARIOUS STEERING GEOMETRIES.

- Camber
- King pin inclination (steering Axis Inclination)
- Combined angle and scrub Radius
- Castor
- Toe – in or Toe out
- Toe change or bump steer

1) Camber angle

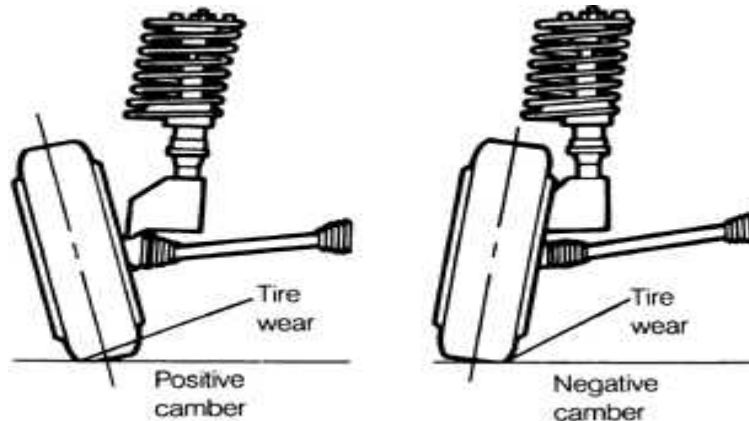

Camber angle

- Camber angle is the angle between the center line of wheel & the vertical line when viewed from front side of a vehicle. It usually varies from +2 degree to -2 degree.
- The camber angle has influences on the tyres ability to generate lateral forces. A cambered rolling pneumatic wheel produces a lateral force in the direction of the tilt. This force is referred to as 'Camber thrust' when it occurs at zero slip angles (e.g. steering straight ahead).
- Camber affects the aligning torque, making the wheels wanting to point straight ahead even when not rolling, due to distortion of the tyres footprint. The effect of this is rather small and tends to be cancelled with increasing slip angle.
- Cambering the wheel also leads to an increase in the lateral force produced by the wheel when cornering. Camber changes as the wheel moves up and down. This change has a linear range and a non-linear range. Lateral forces increase in the linear range of the tyre. If the linear range is exceeded the additive effects of the camber inclination decreases, this effect is called Roll-off.
- Therefore the difference in lateral force when comparing a cambered wheel and a non-cambered wheel is small, around 5-10% at maximum slip angle (e.g. very hard cornering). The difference is much larger at zero degrees slip angle (e.g. straight ahead) due to the camber thrust.

- The effects of cambering the tyre are bigger for a bias ply tyre than a radial ply tyre. For radial tyre the camber forces tends to fall of at camber angles above 5° while the maximum force due to camber for a bias ply racing tyre occurs at smaller angles.
- Camber is measured with a caster camber gauge and is usually easily adjusted with shims or adjustable upper a-arms. Always check the toe when making camber or caster adjustments. This should be done with the driver and any ballast.
- The amount of static camber that you should run is a result of testing, tyre temperature measurements, front suspension geometry etc.
- Setting the camber to 0° will minimizing the rolling resistance.
 - Poor Camber settings will cause :
 - ❖ Excessive tyre wear.
 - ❖ Camber settings set to extremes can reduce the braking ability of the car.
- **Positive camber:** When top side of the wheel is tilted away from the vehicle it is called positive camber. Positive camber is usually preferred for ATV (Automated Transfer Vehicle), heavy & public transport vehicles with rigid axle suspension because the wheels straighten out when heavily loaded vehicle is set in motion.
- **Negative Camber:** When top side of the wheel is tilted towards the vehicle it is called negative camber.
 - ❖ Negative camber increases the area of contact patch thus increasing traction force & tyre grip enabling high speed driving.
 - ❖ Tyre wear is less & uniform as compared to positive camber.
 - ❖ Negative camber angle increases cornering force helping the driver to turn vehicle easily.

2) King pin inclination (steering Axis Inclination)

- Steering Axis Inclination (SAI) is also known as King Pin Inclination (KPI).
- The 'Steering Axis' is the axis around which the wheel assembly swivels as it turns to the right or left. It's formed by drawing a line through the upper and lower ball joint pivots. This axis is not necessary centered on the tyre contact patch. If you view this as from the front it is inclined inwards at the top. 'Steering Axis Inclination' is the angle in degrees between the 'steering axis' and vertical.
- Steering axis inclination (SAI) causes both front wheels to gain positive camber as they steer away from center. This acts with caster to provide self-centering of the front wheels. This gives the car straight line stability.
- With the wheels in the straight-ahead position, the stub axles are almost horizontal.
- As the wheels turn to either side, SAI causes the stub axles to decline and the ends. In order for this to happen the inside end of the stub axle must rise and this in turns raises the front of the car.
- The mass of the vehicle pushes down on the stub axles, so when the steering wheel is released, the wheels are pushed back to the central position.
- Without any inclination, no self centering would occur. The mass of the vehicle would not resist the wheels from being pivoted by the bump (Bump Steer). The steering would be hard to control and straight line stability would be very low.

Steering Axis Inclination Effects

- With positive 'Spindle Length', the car will be raised up as the wheels are turned. There is an increase in the steering moment at the steering wheel. Regardless of which way the front wheels are turned, the larger the Steering Axis Inclination angle is, the more the car will be raised. Without any caster, this effect is symmetrical from side to side. The raise of the car has a self-aligning effect of the steering at low speeds.
- SAI affects the 'Steer Camber'. This is when a wheel leans when the wheels are tuned (positive camber for positive SAI angles). The amount of this is small but not to be neglected, especially for a vehicle making tight high speed turns.

- If the driving or braking force is different on the left and right side (due to wheel spin or skidding), there will be an induced steering torque proportional to the scrub radius. This will be felt by the driver at the steering wheel. Under acceleration this is often called 'Torque Steer'.
- The distance from the 'Steering Axis' to the wheel centre plane measured horizontally at axle height is called 'Spindle length'.
- Steering axis inclination brings the pivot point close to the center of the tyre contact patch at the road surface. It intersects with the camber line drawn through the tyre and the wheel.

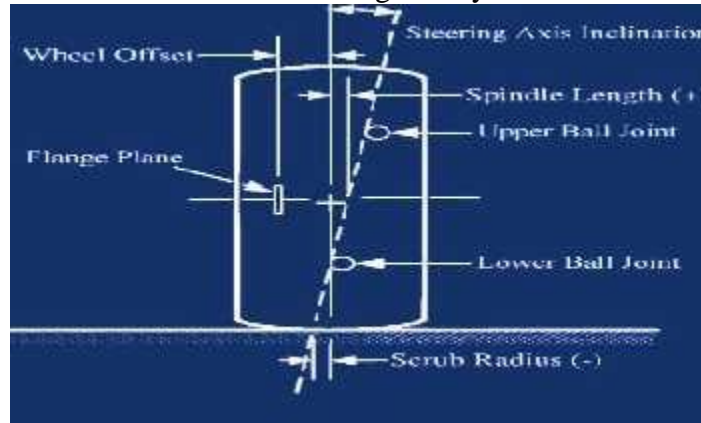

- If these 2 lines intersect at the center of the tyre, at the road surface, then the vehicle is said to have zero offset, or zero Scrub Radius.
- If they intersect above the road surface, then it has negative offset or Scrub Radius (shown above). The angle between the steering axis inclination and the camber line is called the included angle. It is a diagnostic angle.
- If they intersect below the road surface, then it has positive offset or Scrub Radius (shown below)
 - ❖ Steering axis inclination is set by the dimensions of the upright and therefore not adjustable once defined.
 - ❖ Steering Axis inclination is usually kept below 8° since too much SAI causes a lot of rising of the front axle when steering.

Included Angle:

- The sum of the camber and SAI angles in a front suspension. This angle is measured indirectly and is used primarily to diagnose bent suspension parts such as spindles and struts.

3) Combined angle and scrub Radius

- It is the angle formed in the vertical plane between the wheel centre line and king pin centre line.
- It is also said as the combined angle of camber and king pin inclination.

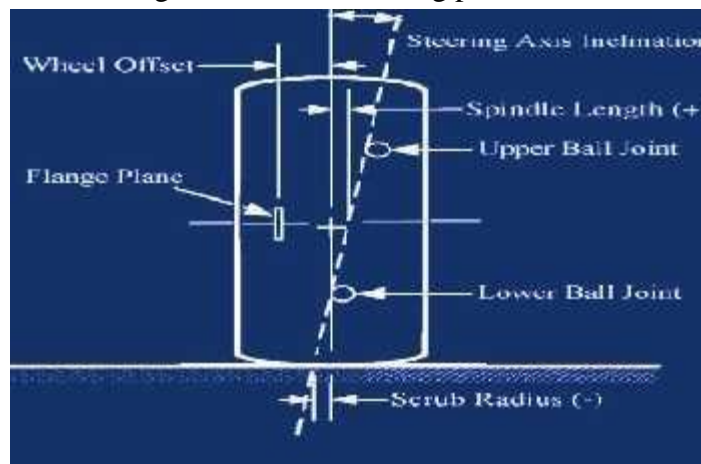

- The scrub radius is the distances in front view between the Steering Axis and the centre of the tyre contact patch where both would theoretically touch the road.
- The “steering axis” is the line between the top pivot point of the hub and the lower ball joint of the hub. The inclination of the steering axis is the angle of inclination from vertical and is known as SAI (Steering Axis Inclination) or KPI (King Pin Inclination).
- If the steer axis intersection point is outboard of the center of the contact patch it is negative, if inside the contact patch it is positive.
- Large positive values of scrub radius, 4 inches or 100 mm or so, were used in cars for many years. The advantage of this is that the tyre rolls as the wheel is steered, which reduces the effort when parking.
- On a rear-wheel-drive vehicle with positive scrub radius, the vehicle’s forward motion and the friction between the tyre and the road causes a force which tends to move the front wheels back, keeping the vehicle heading straight ahead.
- This also allows greater width in the engine bay, which is very important in some compact sports cars. During braking, on any type of drive, if braking effort is greater on one side of the vehicle than the other, positive scrub radius will cause the vehicle to veer towards the side with the greater effort. It therefore requires much higher driver involvement and also competence to maintain control and stop the vehicle being tugged into puddles.
- Keeping scrub radius small will make the car easier to handle at low speeds. It also reduces the risk, that a lose of traction on one front wheel during braking, causes the car to change direction. If the scrub radius is small then the contact patch is spun in place when parking, which takes a lot more effort.
- The advantage of a small scrub radius is that the steering becomes less sensitive to braking inputs, in particular. However, zero scrub radius, under hard braking, causes the suspension to be skittish because varying road conditions created varying amounts of torque (both positive and negative) around the steering axis. Therefore, some amount of scrub radius, positive or negative, is preferred. Having a small amount of scrub radius, under hard braking, generates a small bit of torque to a predictable side. While this torque isn’t desirable, it’s predictable and relatively not-affected by changes in road conditions, which makes the steering smooth.
- An advantage of a negative scrub radius is that the geometry naturally compensates for split braking, or failure in one of the brake circuits. Vehicles with a diagonal-split brake system have negative scrub radius built into the steering geometry. If one half of the brake system fails, then the vehicle will tend to pull up in a straight line.
- Negative scrub radius also provides centre point steering in the event of a tyre deflation, which provides greater stability and steering control in this emergency situation. If you hit a puddle at speed on one side of the car, with negative scrub radius the torque on the steering will steer you away from the puddle. This balances the effect of drag on one side of the car.

4) Caster Angle

- In the side view the inclination of the Steering Axis (also known as kingpin axis) is called ‘Caster Angle’.
- If the ‘Steering Axis’ doesn’t pass through the centre of the wheel then there is a side view ‘Steering Axis Offset’ present. The distance from the steering axis to the centre of the tyre footprint is called ‘Trail’ or ‘Caster offset’.
- Caster angle and trail are of importance when designing the suspension geometry.

The effects to consider are:

- As trail is increased more steering torque or effort is needed.
- Caster angle will cause the wheel to rise and fall with steer. This effect is opposite from side to side and causes roll and weight transfer. Leading to an over-steering effect.
- Caster angle has a positive effect on steer-camber. With positive caster angle the outside wheel will camber in a negative direction and the inner wheel in a positive direction, causing both wheels to lean into the turn.

- The size of the mechanical trail due to caster may not be too large compared to the Pneumatic trail from the tyre. The pneumatic trail will approach zero as the tyres reaches the slip limit. This will result in lowering the self-centering torque that is present due to the lever arm between the tyres rotation point at the ground and the point of attack for the lateral force. This will be a signal to the driver that the tyre is near breakaway. This “breakaway signal” may be lost if the mechanical trail is large compared to the pneumatic trail.

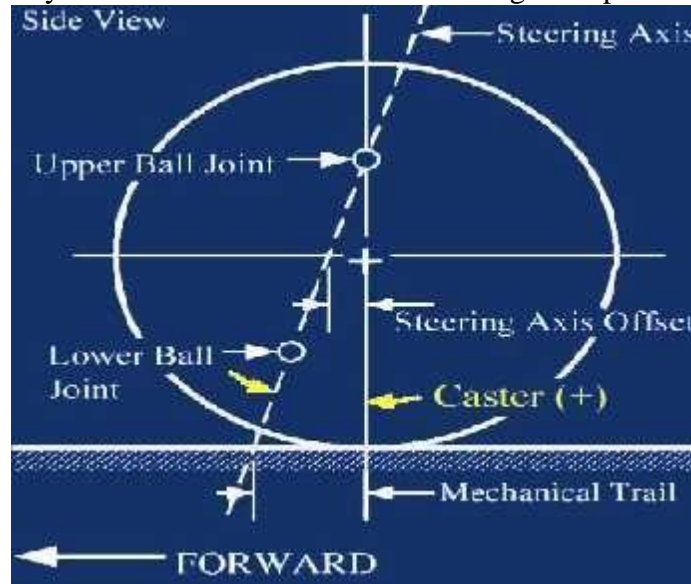

- Caster is measured in degrees by using a caster camber gauge. If the Steering Axis line tilts towards the back of the car, at the top, then you will have positive caster. If the line tilts forward then you would have negative caster.
- Positive caster provides the directional stability.
- Too much positive caster will make the steering effort difficult; however power steering will allow you to run more.
- Negative caster requires less steering effort but can cause the car to wander when driving in straight lines.
- The caster angle has positive effects during cornering but too much caster causes weight transfer that will have an over-steering effect.
- The possibility to adjust the camber angle from 0° to about -4° will be very helpful during the testing of the car.
- Setting the camber to 0° minimizing the rolling resistance during acceleration.

Slip angle

- Even though the name uses the word “slip”, this characteristic has nothing to do with slipping or skidding.
- Slip angle is the angular difference between the direction of the tyres’ contact patch with the road and the direction of the wheel rim. A non-zero slip angle arises because of deformation in the tyres’ carcass and tread. A slip angle results from a combination of tyre sidewall flex and tyre traction.
- When a wheel travels in a direction other than the one its contact patch is pointing, then you have a SLIDE angle rather than a slip angle. A car in fact travels in the direction of the contact patch and not the direction of the wheel rim.
- To see the affect whilst the car is stationary is simple. Small movements of the steering can be made before traction is broken and the wheel actually turns. This is due to the tyres flexing. As the slip angle increases, more of the contact patch is slipping. Eventually, so little of the contact patch is slipping, that traction is lost and the tyre begins to slide. Slide traction increases linearly virtually until traction is lost, then increases more gently allowing the driver some degree of control before final loss of traction.

- Unlike the rear axle, if a large amount of slip you can adjust the steering to keep the car traveling in the desired direction. This situation is known a ‘Understeer‘.

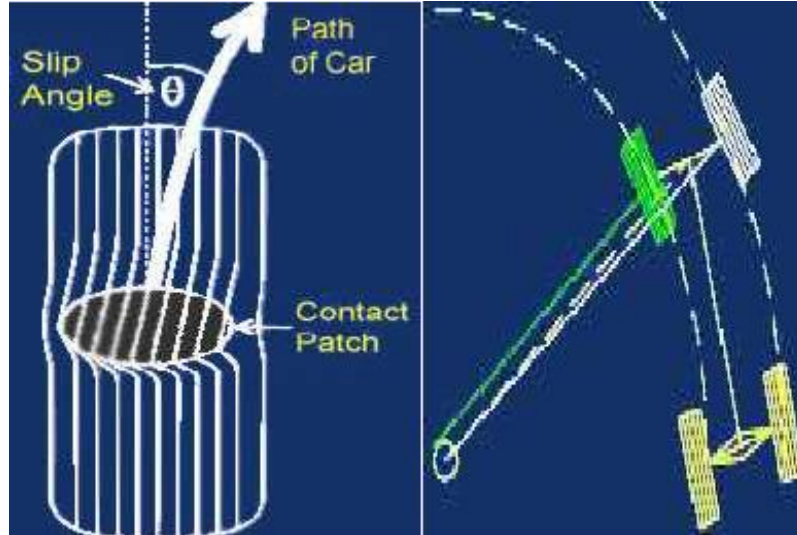

Slip angle

- It can be seen in the diagram left that both rear wheels have a large amount of slip and inside front tyre is also generating slip.
- Increasing the slip angles at the rear tends make the car looser (oversteer). Likewise, reducing the slip angles at the rear can be interpreted by the driver as making the car feel ‘tighter’.
- Increasing the weight transfer towards the front, increases the slip angles on the front wheels. This may require a larger steering wheel angle (Understeer). Reducing weight transfer will have the opposite effect.

Items that effect weight transfer and slip are:

- Spring rates
- Spring locations
- Sway bar rate
- Weight distribution
- Brake Balance
- Height of the roll centers
- roll stiffness
- Addition of an anti-roll bar

What else effects slip angles?

- Acceleration and braking (primarily because of weight transfer and toe-angle changes)
- Tyre profile size
- Camber – More camber equals greater camber thrust. Camber thrust attempts to turn your wheel into a turn in the direction of lean. Therefore more camber thrust gives smaller slip angles.
- As passenger cars are often only exposed to low lateral accelerations, Ackermann steering is set-up to ensure that all wheels roll freely with no slip angles because the wheels are steered to track a common turn centre.
- Race cars can operate at high lateral accelerations and therefore all the tyres operate at significant slip angles and the loads on the inside wheels are much less than the outside wheels due to the lateral load transfer.
- Race cars use Parallel or even Reverse Ackermann, as low speed steering geometry would cause the inside tyre to be dragged along at much higher slip angles than needed. This would result in raised tyre temperatures, slowing the car down due to slip induced drag.

5) Toe In / Toe Out

- The amount of toe is expressed in degrees, as the angle from parallel of the front wheels. Sometimes Toe is expressed as the difference between the track widths of the leading and trailing edges of the front wheels.
- Toe adjustment can be used to overcome handling difficulties in the car. Rear toe-out (independent rear suspension) can be used to improve the turn-in. As the car turns in the load transfer adds more load to the outside wheel and the effect is in an over-steer direction. The amount of static toe in the front will depend on factors such as Ackermann steering geometry, ride and roll steer, compliance steer and camber.
- For minimum tyre wear and power loss, the steering wheels should be parallel and point directly ahead when the car is running in a straight line. Toe settings have similar effects when applied to the rear wheels.
- Excessive toe-in or toe-out causes the tyres to scrub, since they are always turned relative to the direction of travel.
- Angles of Toe are set in conjunction with Ackermann geometry so set steering performance in bends.
- Before making any Toe adjustments, make sure the steering is straight ahead. For a truly accurate method, measure the both steering arms to identical mirrored parts of the chassis.

Toe settings affect three major areas of performance:

- Tyre wear
- Straight-line stability
- Corner entry handling characteristics.

Toe Angles:

- For a vehicle to have Zero Toe both front wheels would be parallel and pointing directly forward.
- For a vehicle to have Toe IN the leading edges of both wheels are pointed slightly towards each other.
- For a vehicle to have Toe OUT the trailing edges of the front wheels are pointed slightly towards each other

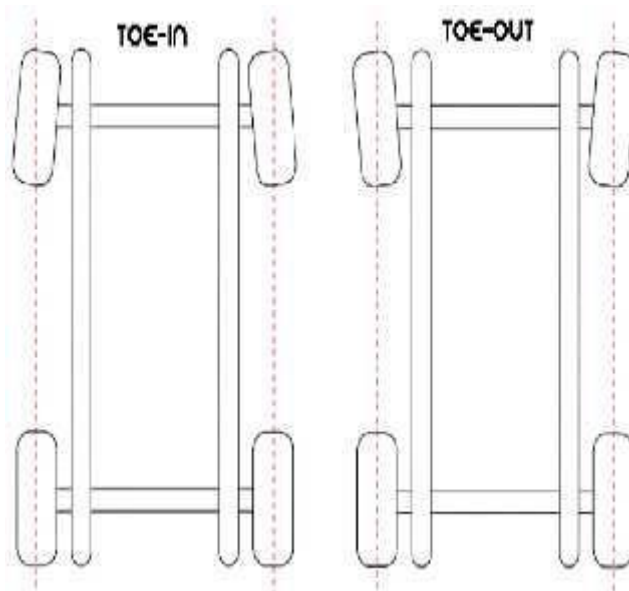

So why have Toe?

- Minimum tyre wear and power loss are achieved with zero toe, so why have any toe angles at all? Toe settings have a major impact on directional stability.
- Toe settings become a tradeoff between the straight-line stability (toe-in) and the quick steering response (toe-out) and tyre wear. Driving a passenger car with low straight line stability can be very tiresome, but racing cars sacrifice a bit of stability on the straightaway for a sharper turn-in to the corners. Therefore, passenger cars are generally set up with a small amount of toe-in, while race cars are often set up with toe-out.

- For more information on Toe see Ackermann Geometry
- Bump steer is the change in toe angle due to wheel travel.

Toe In

- With the steering wheel centered, toe-in causes the wheels to tend to roll along paths that intersect each other. Under this condition, the wheels are at odds with each other, and no turn results. The vehicle wants to drive in a straight line and the steering would naturally try to self centre.
- When the wheel on one side of the car encounters a bump, that wheel is pushed rearward about its steering axis. This action also pulls the other wheel in the same direction. If it's a minor disturbance, the disturbed wheel will steer only a small amount, so that it's rolling straight ahead instead of toed-in slightly.
- With slight steering inputs, the wheels have absorbed the irregularity without significantly changing the direction of the vehicle. In this way, toe-in enhances straight-line stability.
- Passenger cars are usually equipped with soft rubber bushes. Distortion in these bushes actually allows the wheels to track parallel and reduce tyre wear.
- Racing cars on the other hand have joints with spherical bearings with optimum rigidity, thus a road car requires greater toe-in.
- A small degree of toe-in on a car with positive camber will cancel the turning tendency caused by camber, reducing wear and rolling resistance.
 - ❖ Toe In promotes straight line stability.
 - ❖ Too much toe-in causes accelerated wear at the outboard edges of the tyres.

Toe Out

- Toe out promotes a very quick and light feeling steering response.
- The front wheels are aligned so that if a steering wheel hit a bump the vehicle will tend to turn towards it. Any minute steering angle beyond the perfectly centered position will cause the inner wheel to steer in a tighter turn radius than the outer wheel. Thus, the car will always be trying to enter a turn, rather than maintaining a straight line of travel. So it's clear that toe-out encourages the initiation of a turn, while toe-in discourages it.
- Front wheel drive cars with independent suspension are often set up with a bit of toe-out on the rear wheels, as this induces a bit of over-steer to counteract the greater tendency of front-wheel-drive cars to under-steer. Doing this on a rear wheel drive car could cause excessive over-steer, particularly when power is applied.
- A small degree of toe-out for car with negative camber will cancel the turning tendency caused by camber, reducing wear and rolling resistance.
 - ❖ Toe out promotes a very quick and light feeling steering response.
 - ❖ Too much toe-out causes wear at the inboard edges.

5. SKETCH AND EXPLAIN STEERING MECHANISM. DEDUCE AN EXPRESSION FOR TRUE ROLLING OF A STEERING WHEEL.

- Ackermann angle steering geometry solves the problem of wheels on the inside and outside of a turn needing to scribe circles of different radii. Ackermann is often mis-spelt Ackerman.
- Rudolf Ackermann (1764 – 1834) was the patent agent for German horse drawn coach builders “Lankensperger”. They submitted a patent in 1818, but Erasmus Darwin was said to have had prior claim to the invention in 1758.
- The Ackerman steering gear mechanism consist of cross link “CD” connected to the short axels “AL” and “BM” of the two front wheel through the sort arms “AC” and “BD” forming bell crane levers LACD and BMCD respectively .
- When the vehicle is taking a turn, the inside wheel must follow a tight curve than the outside wheel .When the vehicle is running straight the cross link “CD” is parallel to “AB” the short arms “AC” and “BD” both make angle to the horizontal axis of chassis.
- The angles θ and ϕ are shown in figure. The value of b/L is between 0.4 to 0.5.

- For correct steering $\cot \alpha - \cot \beta = b/l$.
- In Ackerman steering gear, there are three positions to be observed in fact. The value of α will be different as the vehicle is running straight, vehicle is taking a left turn and vehicle is taking a right turn.

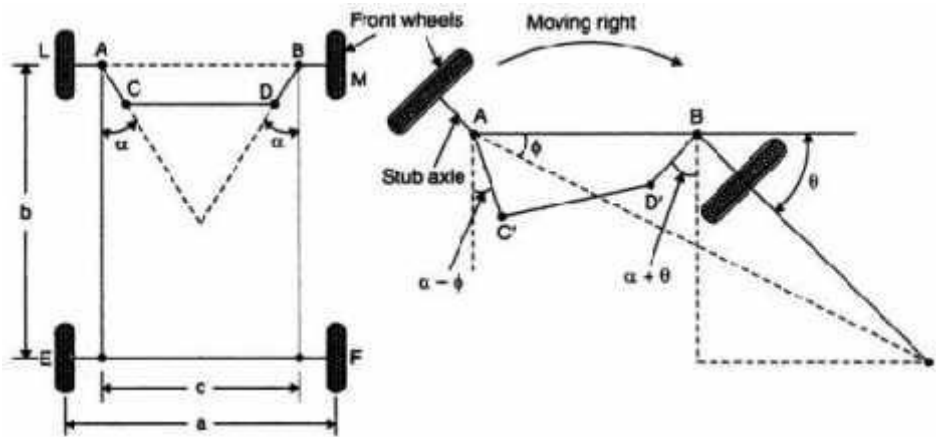

For straight drive

For Right drive

by deriving

$$\tan \alpha = \frac{\sin \phi - \sin \theta}{\cos \phi + \cos \theta - 2}$$

The values of angles ϕ and θ to be taken in this equation are those found for correct steering. Further, when value of angle θ is known, the length of track arm can easily be determined.

- Passenger cars have a steering geometry somewhere between True / Pure Ackermann steering and parallel steering while it's common among race cars to use Reverse Ackermann. By using True / Pure Ackermann steering on passenger cars, or other vehicles only exposed to low lateral accelerations, it is ensured that all wheels roll freely with no slip angles because the wheels are steered to track a common turn centre.
- Race cars are often operated at high lateral accelerations and therefore all tyres operate at significant slip angles and the loads on the curve inner wheels are much less than the curve outer wheels due to the lateral load transfer.
- Tyres under low loads require less slip angle to reach the peak of the cornering force. Using a low speed steering geometry on a race car would cause the curve inner tyre to be dragged along at much higher slip angles than needed and this would only result in raises in tyre temperature and slowing down the car due to the slip angle induced drag. Therefore race cars often use parallel steer or even reverse Ackermann.
- The inside wheel on a bend will need to turn more the outside wheel. In turning a tighter circle, the inside wheel will complete less revolutions.
- Too much Ackermann angle from True, will make the car loose on turn exit or will cause premature tyre wear. Too much Ackermann can over-heat the left front tyre so that it will not perform on a long journey.
- Excessive Ackerman can sometimes be seen by the wear pattern on the left front tyre. If you see a grain pattern in the tyre surface or the left front tyre seem very hot you may want to consider reducing the amount of Ackermann.
- The right amount of Ackermann will help through the middle of a turn. Fine tuning car handling is possible through changes in Ackermann. A car that is overly tight through the middle of a bend can be cured by more Ackermann. Too much can slow the car down as your Engine power is used to overcome tyre drag. Tyre wear may also be an issue.

- It is important to remember that adjusting Toe angles will affect Ackermann Geometry. It is also important to understand the difference between increased Toe Out and More Ackermann as many reference sources often confuse the two.
- Before taking any Ackermann measurements you must insure that ride height is set, weight percentages correct, driver weight accounted for, bump steer set, camber and caster set, air pressure set etc.... All of these factors will have an effect on Ackermann measurements and getting a stable 'Base Point' as reference is very important.

for correct steering,

$$\begin{aligned} \cot \phi &= \frac{y+c}{b} \\ &= \frac{y}{b} + \frac{c}{b} = \cot \theta + \frac{c}{b} \end{aligned}$$

(ϕ = angle of outside lock)

(θ = angle of inside lock)

$$\therefore \cot \phi - \cot \theta = \frac{c}{b}$$

Equation represents the basic condition for the steering mechanism for perfect rolling of all wheels.

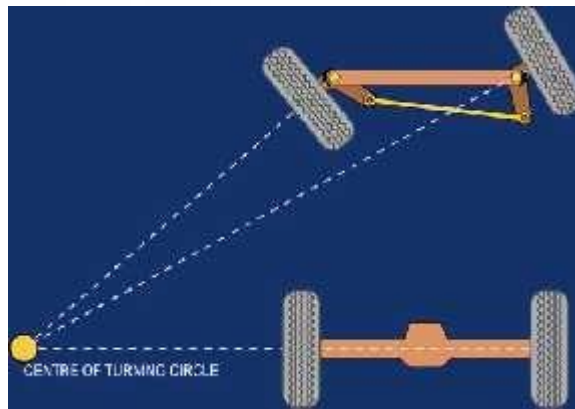

True / Pure Ackermann Steering

True / Pure Ackermann – Zero Toe On Turn In

- True Ackermann steering geometry is defined by angling the steering arms so that a line drawn between both the king pin and steering arm pivot points intersects with the centre line of the rear axle.
- As this gives true Ackermann steering geometry, there is no Toe Angle change on the inside wheel (the wheel is aligned with the circumference of the circle).

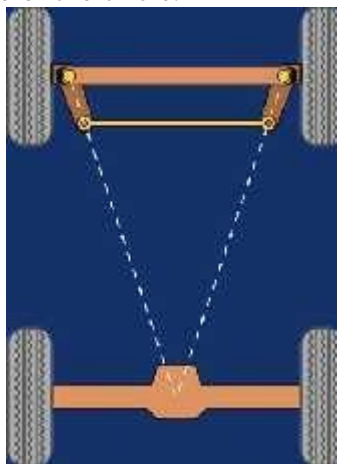

True Ackermann and Zero Toe In:

- Modern cars do not use 'Pure' Ackermann angles as there are many other factors to take into account.
- Zero toe (wheels pointing straight ahead) and True/Pure Ackermann will result with both tyres being aligned with the circumference of the circle or arch of corner.

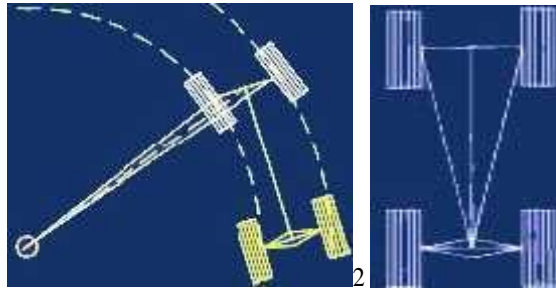

True Ackermann and Toe In:

- Both of the wheels are being toed-in relative to the circumference of the circular path they are actually following.
- The inner wheel is trying to scribe a larger circumference and the outer wheel a smaller one.
- This situation is known as 'Parallel Ackermann'. If Less Ackermann angle was introduced the situation could be pushed into 'reversed ackermann'.

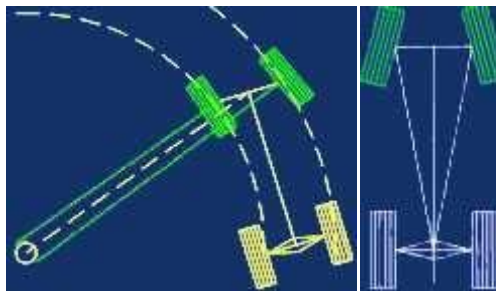

True Ackermann and Toe Out:

- Both of the wheels are being toed-out relative to the circumference of the circular path they are actually following.
- The inner wheel is trying to scribe a smaller circumference and the outer wheel a larger one.

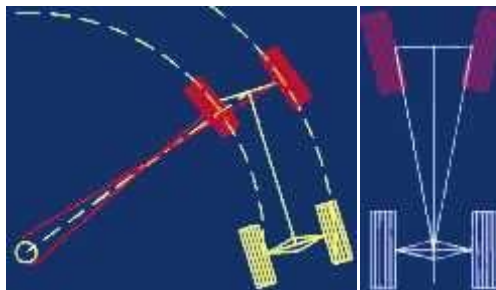

More Ackermann Angle – Toe Out On Turn In

- More Ackermann is achieved by angling the steering arms towards the central axis, so that the point of intersection is forward of the centre line of the rear axle.
- This steering geometry achieves greater angular inequality of the turned wheels, which generates Toe OUT on the front inside wheel. The inside wheel is trying to turn tighter circle than it needs to.

More Ackermann and Zero Toe :

- Zero Toe and More Ackerman will result in the inside wheel trying to follow a smaller diameter circle than it actually does. The inside wheel is toed-in relative to the actually circular path.

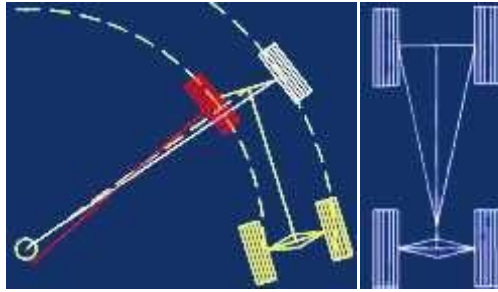

More Ackermann and Toe In:

- By precisely adjusting the toe in angle, the inside wheel could scribe a circumference true to the path it actually follows. The outside wheel is toed-in and is trying to follow a smaller circle than it's actual path. The inside wheel has less toe-in than 'True Ackermann and Toe In'.

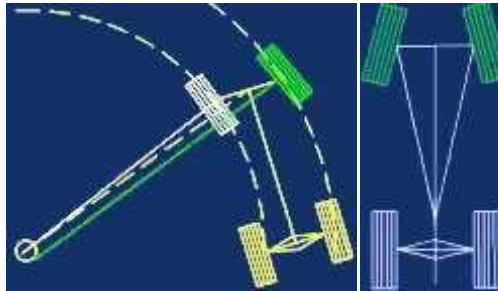

More Ackermann and Toe Out:

- With toe angle set to out and More Ackermann will result with the a larger inequality between the turned front tyres. The outside wheel is toed-out and trying to follow a larger circumference than the circular path.
- The inside wheel also toed-out and is trying to follow a smaller circle than it actually is. The outside wheel has increased toe-out over 'True Ackermann and Toe-Out'.

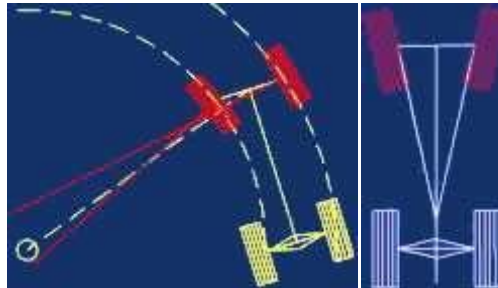

Less Ackermann Angle – Toe In On Turn In

- Less Ackermann angle can be set on a steering set-up, which involves adjusting the angle of the pivot points on the steering arms so that the point of intersection is behind the centre line of the rear axle.
- Some race cars use Reverse Ackermann geometry to compensate for the large difference in slip angle between the inner and outer front tyres while cornering at high speed.
- The use of such geometry helps reduce tyre temperatures during high-speed cornering but compromises manoeuvring in low speed manoeuvres.

Less Ackermann and Zero Toe :

- Less Ackermann and Zero Toe In will result in progressive Toe In on the inside wheel. The Inside wheel will try to follow a greater circle than it actually does. This situation can approach Parallel Ackermann.

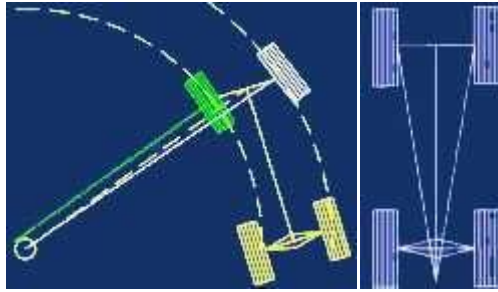

Less Ackermann and Toe In:

- Both of the wheels are being toed-in relative to the circumference of the circular path they are actually following.
- The inner wheel is trying to scribe a larger circumference and the outer wheel a smaller one. The inner wheel has increase toe-in over 'True Ackermann and Toe In' above. This situation is known as 'Reverse Ackermann'.

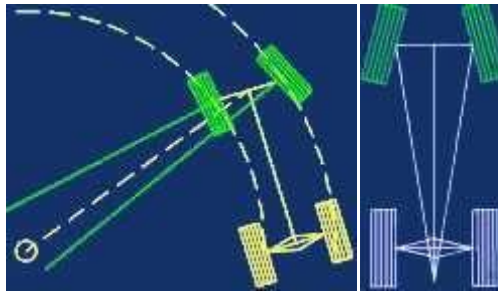

Less Ackermann and Toe Out:

- By precisely adjusting Toe Out the inside wheel could scribe a path true to circumference of the circular path it is actually following. The outside wheel is toed-out relative to the circumference of the circular path it is actually following. The inside wheel has less toe-out than 'True Ackermann and Toe-Out'.

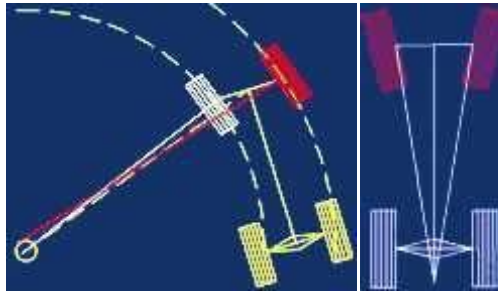

Davis steering mechanism

- The Davis steering gear has sliding pairs, whereas the Ackerman steering gear has only turning pairs. The sliding pair has more friction than the turning pair. Therefore the Davis steering gear will wear out earlier and become inaccurate after certain time.
- Although, the Ackerman steering gear is not mathematically accurate except in their position, contrary to the Davis steering gear which is mathematically correct in a position
- However, Ackerman steering gear is preferred to Davis steering gear
- Davis steering Gear : The Davis steering gear mechanism consist of a cross link "CD" sliding parallel to another link "AB" and its connecting to the stub axles of the two front wheels by means of two similar bell crane levers "LAC" and "MBD" pivoted at "A" on the "B" respectively. The cords link "CD" slides on the bearing and carries pins at its ends "C" and "D". The slide blocks are pivoted on these pins and move with the turning of bell crane levers as the steering wheel is operated. When the vehicle is running straight, the

gear is said to be in mid position. The short Arms “AC” and “BD” are inclined at an angle of “ $90 + 0C$ ” to their stub axles “AL” and “BD” respectively

- $\tan \alpha = c/2l$
- Where $c = AB =$ distance between the points of front axles. $l =$ wheel base
- The range of c/l is 0.4 to 0.5. Hence the angle “ α ” lies between 11.3° and 14.1°

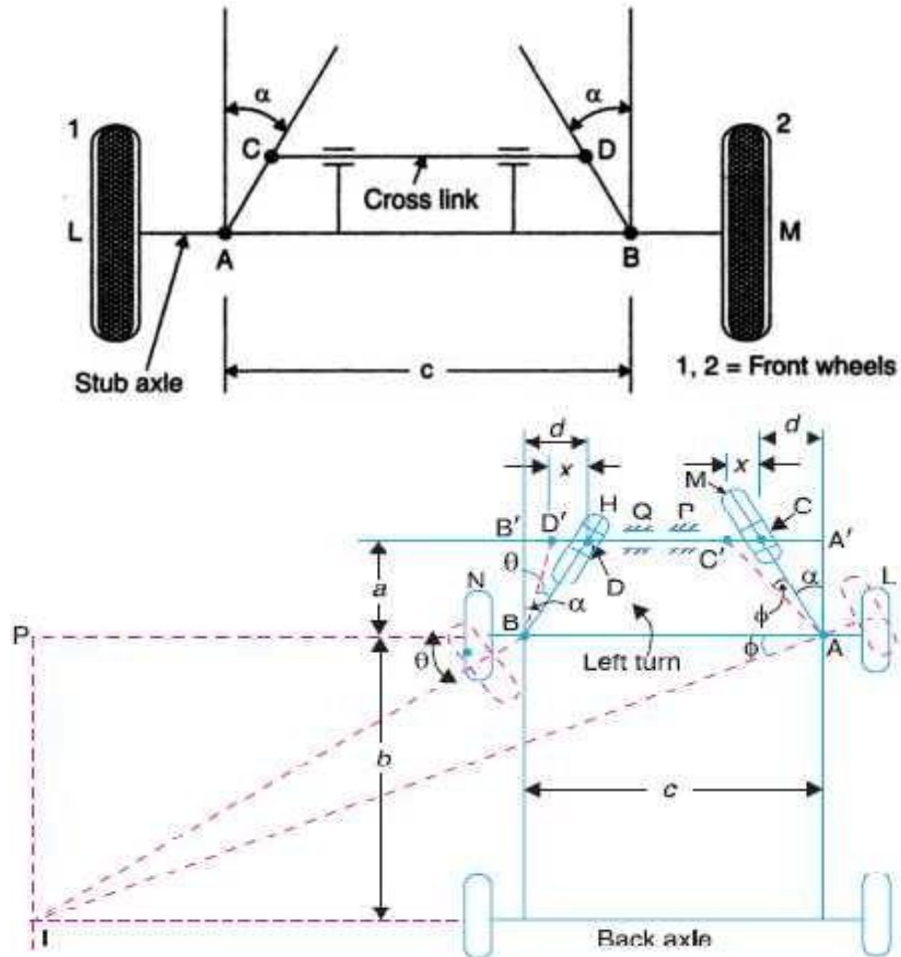

Davis steering mechanism

- Let
- a – Vertical distance between AB and CD ,
 - b – Wheel base,
 - d – Horizontal distance between AC and BD ,
 - c – Distance between the pivots A and B of the front axle.
 - x – Distance moved by AC to $AC' = CC' = DD'$, and
 - α – Angle of inclination of the links AC and BD , to the vertical.

From triangle $AA'C'$,

$$\tan(\alpha + \phi) = \frac{A'C'}{AA'} = \frac{d + x}{a} \quad \dots(i)$$

From triangle $AA'C$,

$$\tan \alpha = \frac{A'C}{AA'} = \frac{d}{a} \quad \dots(ii)$$

From triangle $BB'D'$,

$$\tan(\alpha - \theta) = \frac{B'D'}{BB'} = \frac{d - x}{a} \quad \dots(iii)$$

We know that
$$\tan(\alpha + \phi) = \frac{\tan \alpha + \tan \phi}{1 - \tan \alpha \cdot \tan \phi}$$

or
$$\frac{d + x}{a} = \frac{d/a + \tan \phi}{1 - d/a \times \tan \phi} = \frac{d + a \tan \phi}{a - d \tan \phi}$$

...[From equations (i) and (ii)]

$$\tan \phi = \frac{ax}{a^2 + d^2 + dx} \quad \dots(iv)$$

Similarly, from $\tan(\alpha - \theta) = \frac{d - x}{a}$, we get

$$\tan \theta = \frac{ax}{a^2 + d^2 - dx} \quad \dots(v)$$

We know that for correct steering,

$$\cot \phi - \cot \theta = \frac{c}{b} \quad \text{or} \quad \frac{1}{\tan \phi} - \frac{1}{\tan \theta} = \frac{c}{b}$$

$$\therefore 2 \tan \alpha = \frac{c}{b} \quad \text{or} \quad \tan \alpha = \frac{c}{2b}$$

Ackerman Vs Davis

- The whole mechanism of Ackerman steering mechanism is on the back of the front wheels.(Turning pair)
- Where as in Davis steering mechanism, it is in front of the wheels.(Sliding pair)
- The Ackerman steering mechanism is mostly used because the true rolling is achieved by the instantaneous center

Note. Davis steering gear is *theoretically correct*, but due to presence of more sliding members, the wear will be increased which produces slackness between the sliding surfaces, thus *eliminating the original accuracy*. Hence this gear is *not in common use*.

6. VEHICLE HANDLING

1. Factors affecting handling
2. Common handling problems
3. Practical compromises
4. Effects of modifications and adjustments

1. Factors affecting handling

- **Weight distribution**
 - ❖ handling is improved by lower center of gravity
 - ❖ Front-heavy vehicles tend to understeer while rear heavy vehicles tend to oversteer
- **Polar moment of inertia**
 - ❖ Roll polar MOI increases the time taken to settle down and follow the steering after cornering

- ❖ Yaw polar MOI tends to keep the direction of the car changing at constant rate
- ❖ Pitch polar MOI contributes to bump steer. Thus a heavy bumper would increase pitch MOI and so has to be avoided
- **Suspension**
 - ❖ The spring rate, damping, straight ahead chamber, camber change with wheel travel, rill center height and vibration modes and the flexibility of the suspension elements, affect the vehicle handling
- **Rigidity of the frame**
 - ❖ Rigidity is seen in help handling
- **Unsprung weight**
 - ❖ Unsprung weight is cushioned from road shocks only by the tyres, which have limited internal damping. Thus the wheel bounce is only poorly damped by shock absorbers due to which high unsprung weight reduces road handling and increases unpredictable changes in direction on rough roads
- **Wheel base and wheel truck**
 - ❖ Large wheel base increases resistance to front / back weight transfer, while sideways weight – transfer resistance is provided by the wheel track.
- **Wheel and tyres**
 - ❖ Larger types, soft rubber and more stiff cords increase road handling and improve handling.
 - ❖ The depth of tread affects the water removal efficiency of tyres on wet roads.
 - ❖ In general, increase the tyre pressure reduces their slip angle, but for given road conditions and loading, there is an optimum value of the pressure at which holding is best.
- **Steering**
 - ❖ Rack and pinion steering is considered the best for handling.
 - ❖ Steering geometry changes due to road bumps may cause front wheels to steer in a different direction, thus deteriorating handling.
 - ❖ Back lash and excessive friction in the steering mechanism also affects the vehicle handling adversely. Steering precision is particularly important on ice or hardened snow where the limiting slip angle is smaller than on dry roads.
- **Throttle and brakes**
 - ❖ The weight transfer takes place in rearward direction during acceleration, which would cause oversteer. This is opposite of the tendency of the vehicle to understeer during negotiating a tight curve. Either of these two effects may dominate depending upon the conditions.
 - ❖ Using low gear while going down steep hills ,may cause some oversteer.
 - ❖ During braking, forward weight transfer takes place which would favour understeer. However the effect due to type of road surface is also added to it, which makes the result unpredictable. Most modern cars counter this by varying the distribution of braking in some way.
- **Aerodynamics**
 - ❖ Aerodynamics forces are proportional to square of the air speed. As such these are important at high vehicle speed. Negative lift downward force used on many racing cars and also on many passenger cars to improve road handling
- **Miscellaneous**
 - ❖ Position and support for the driver.
 - ❖ Road condition

2. Common handling problems

- **Understeer**
 - ❖ The driver can compensate by turning the steering wheel a little more, but road handling is reduced and vehicle behavior is less predictable.

➤ **Oversteer**

- ❖ The driver has to rectify by steering away from the corner. However, this tendency may be useful in assisting steering sometimes when the driver chooses it applying power.

➤ **Body roll**

- ❖ The tendency of the vehicle to roll out during turns, interfaces with the drivers control and also causes delay in negotiating the turn.

➤ **Weight transfer**

- ❖ During cornering, the weight transfer takes place from the inner side wheels to the outer side wheels, which may result in oversteer depending upon various conditions.

➤ **Response**

- ❖ During negotiating corners, the response slows down. Sideways acceleration does not start immediately when the steering is turned and does not stop immediately when the steering is returned to straight ahead. This occurs due to body roll, high slip angle tyres, and yaw & roll angular inertia.

3. Practical compromises

- Inboard brakes improve both handling and comfort , but take up more space and are difficult to cool
- Large engines tend to make vehicles front or rear heavy
- Wishbone front suspension gives better handling, because of greater flexibility for the engenderers to choose steering geometry. However, it takes more spaces
- For tyre design, factors favoring fuel economy, staying cool at high speeds, ride comfort and long life, all tend to reduce road- holding

4. Effects of modifications and adjustments

Decrease Understeer	Decrease Oversteer	Adjustments
Higher	Lower	Front Tire Pressure
Lower	Higher	Rear Tire Pressure
Larger	Smaller	Front Tire Section
Smaller	Larger	Rear Tire Section
More Negative	More Positive	Front Wheel Camber
More Positive	More Negative	Rear Wheel Camber
Toe Out	Toe In	Front Toe
Toe Out	Toe In	Rear Toe
More Positive	More Negative	Front Caster
Soften	Stiffen	Front Springs
Stiffen	Soften	Rear Spring
Smaller	Larger	Front Sway Bar
Larger	Smaller	Front Sway Bar

7. EXPLAIN THE STEERING LINKAGE WITH SUITABLE SHETCH.

Primary function of the steering system is to achieve angular motion of the front wheels to negotiate a turn. This is done through linkage and steering gear which convert the rotary motion of the steering wheel into angular motion of the front road wheels. Secondary functions of steering system are:

- To provide directional stability of the vehicle when going straight ahead. .
- To provide perfect steering condition, *i.e.*, perfect rolling motion of the road wheels at all times.
- To facilitate straight ahead recovery after completing a turn.
- To minimize tyre wear.

Till recently all vehicles were steered by turning the front wheels in the desired directions, with the rear wheels following. However, lately all-wheel steering has been designed and employed in some selected vehicles. Here only

Front wheel steering would be discussed which is being used universally till today.

The requirements of a good steering system are:

- The steering mechanism should be very accurate and easy to handle.
- The effort required to steer should be minimal and must not be tiresome to the driver.
- The steering mechanism should also provide directional stability. This implies that the vehicle should have a tendency to return to its straight ahead position after turning.

The main causes of stiff steering include

- Insufficient lubrication of the king-pins or steering linkage
- Tyre pressure too low,
- Wheels out of track, toe-in not correct, and
- Stiffness in the steering column itself, caused by lack of lubricant or over tightening.

Components of steering system- Steering linkages

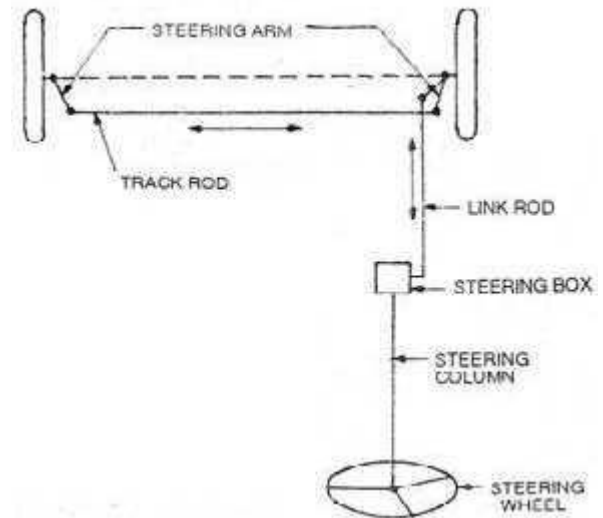
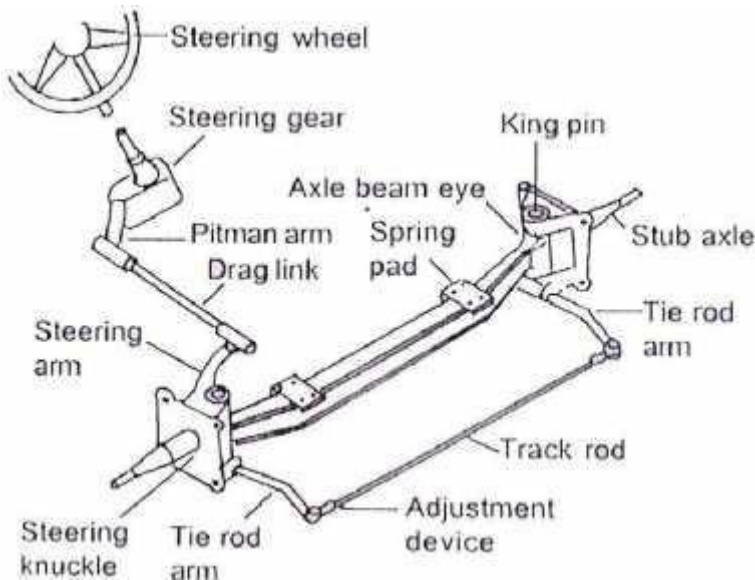

Steering linkage

- The steering linkage is a connection of various links between the steering gear box and the front wheels. The motion of pitman arm of steering gearbox is transferred to the steering knuckles of the front wheels through the steering linkage.
- When the steering wheel is turned to the left or right, the pitman arm swings from one side to the other. This movement of the pitman arm gives angular movement to the front wheels through the steering linkage.
- The most commonly used steering linkage is conventional steering linkage. The pitman arm (drop arm) is connected directly by a connecting link namely drag link to a steering knuckle arm attached to the left hand steering knuckle. The motion is carried across from this arm to a steering arm on the right side steering knuckle by means of the rod. The drag link and drop arm (Pitman Arm) are mounted on the left side of the frame.
- In some designs the drag link is connected between the drop arm and right steering knuckle arm by locating drop arm beneath the steering gear.

- In direct cross type steering linkage, the pitman arm (Drop Arm) is connected directly to one end of the rod which its other end is connected to another. The other ends of the rods are connected to the steering arms.

Under steering, over steering and Turning Radius

- While taking a turn, the wheels are not always pointing in direction in which the vehicle is moving, due to distortion of tyre tread. The angle between the wheel inclination and the path taken by the wheel is known as “Slip angle”. When the slip angle is greater at the rear than of the front, the vehicle tends to “over steer” the vehicle is to turn into the curve more than the driver intended.
- When the slip angle is smaller at the rear than at the front, the vehicle tends to “under steer”.
- The under steer is most commonly preferred because correction by the driver involves rotating the steering wheel a little more in the direction of the turn.
- It can be noted that the slip angle is affected by the road camber side winds, tyre inflation and variations in the load on either the front or rear axle.
- Turning Radius : Turning radius is the radius of the circle on which the outside front wheel moves when the front wheels are turned to their extreme outer position.
- This radius is 5 to 7m for buses and trucks. The turning radius is usually proportioned to the wheel base of the vehicle, because the maximum rotation of the steering knuckle is seldom more than 35 degrees.

Different types of steering linkages

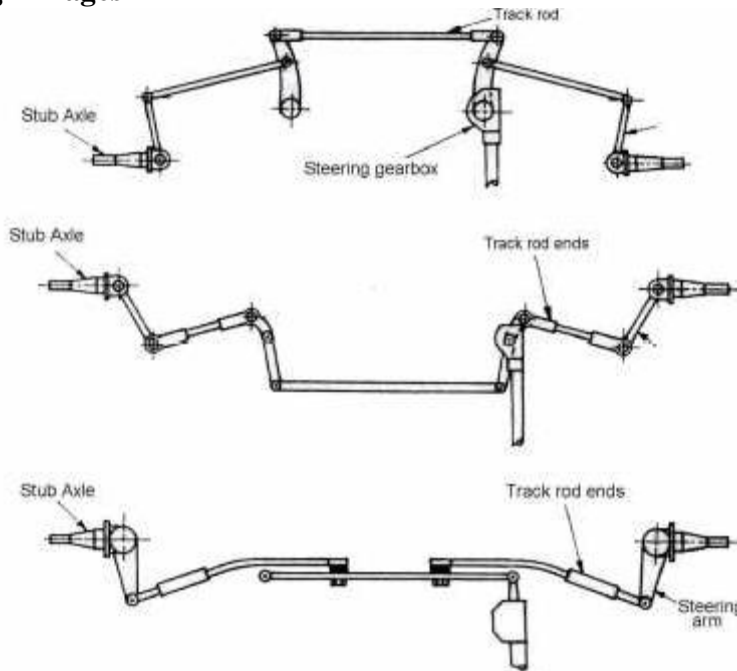

Independent Suspension Steering System

- In the rigid-beam suspension, the stub-axle is pivoted at each end of the axle-beam. Consequently the relative movement is permitted only in the horizontal plane due to which effective track-rod length is not affected by any vertical suspension deflection.
- Independent-suspension steering, on the other hand, copes with up a down movement of each stub-axle independent of the other due to which the distance between track-rod-arm ball-joint centres varies continually.
- Therefore, if a single track-rod joins the two stub-axles together, the slightest bump or rebound tends to pull both stub-axle arms at once and thus interferes with the steering-track toe-in or toe-out.

- To overcome the problem of the changing distance between track-rod-arm ball-joint centres, a three-piece track-rod is used. The centre portion of the track rod may be a relay-rod suspended between the steering-box drop-arm and an idler arm fixed to the body structure.
- Also the centre portion may form part of the track shaft of a rack-and-pinion steering-box. In both the cases, this part moves only in the horizontal plane. Movement in the vertical plane is provided by the two outer connecting rods, known as tie-rods. The tie-rods swing about the ball-joints placed at the end of the middle track rod member. In earlier designs, independent suspension steering incorporated stub-axles and king-pin pivots similar to those used with the axle-beam. But current systems use ball-swivel joints for the stub axle pivot and are also spaced further apart
- Large cars normally use the system shown in Fig. When the steering-wheel is acted, the drop-arm conveys movement to the relay-rod, which in turn transmits this motion to both tie-rods and stub-axles. The drop-arm and idler-arm relay joints provide movement only in the horizontal plane. The tie-rod joints provide movement in both the horizontal and vertical planes.
- The most popular steering system used for small and medium cars is shown in Fig. This type of steering box has a rack-and-pinion housing bolted along the body cross-member. The angular movement of steering wheel is converted to a linear to-and-fro movement of the rack. Each end of the rack shaft is attached to a tie-rod by means of a ball-and-socket joint. The outer tie-rod ends also use ball-joints, which are bolted to the stub-axle track-rod arms. The rack shaft thus provides the transverse steering thrust and the tie-rod ball joints allow pivoting in two planes.

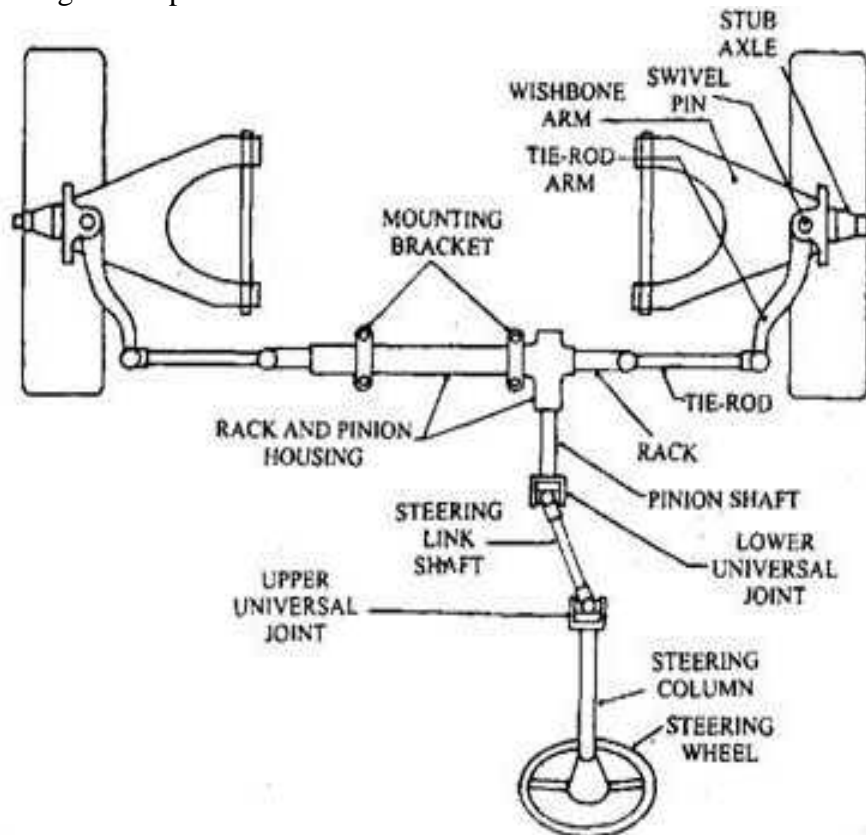

Split track-rod with relay-rod and idler steering linkage layout.

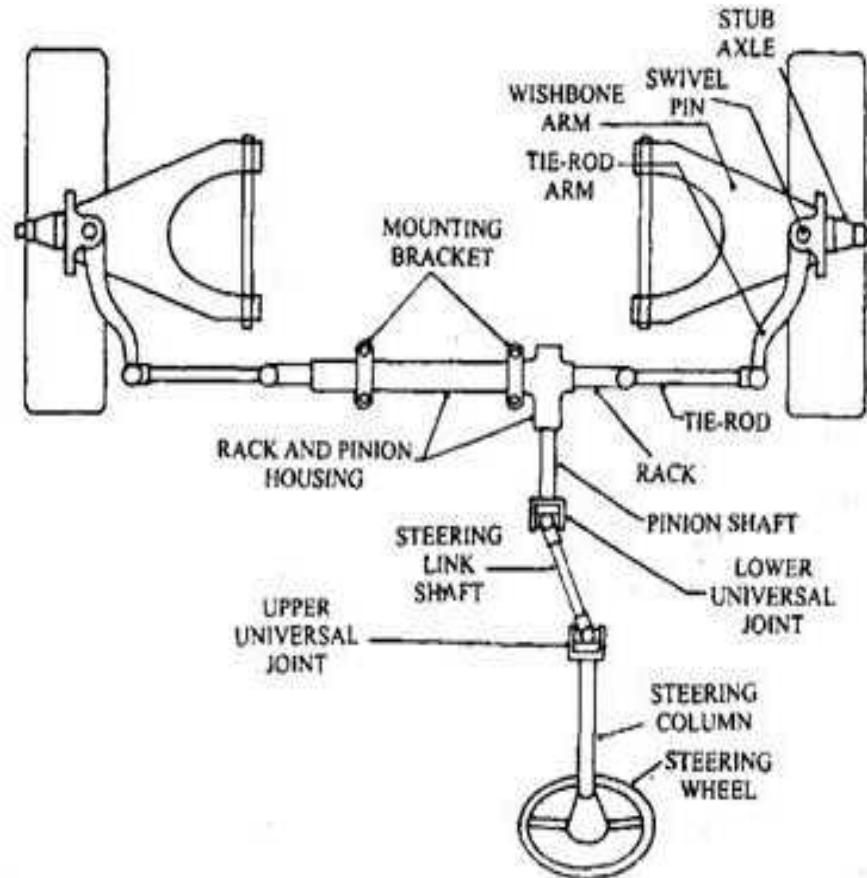

Rack-and-pinion steering linkage layout.

8. WHAT ARE THE DIFFERENT TYPES OF STEERING GEARS? WHAT IS THE PURPOSE OF STEERING GEAR? EXPLAIN WITH SKETCH OF STEERING GEARS.

Steering Gear

- One of the important human interface systems in the automobile is the steering gear.
- The steering gear is a device for converting the rotary motion of the steering wheel into straight line motion of the linkage.
- The steering gears are enclosed in a box, called the steering gear box.
- The steering wheel is connected directly to the steering linkage it would require a great effort to move the front wheels. Therefore to assist the driver, a reduction system is used.

Functions of Steering Gears:

- It helps to multiply a small effort applied on the steering wheel by driver into a greater force on the dragging link.
- It functions to transform the rotary motion of the steering wheel into the to-and-from motion of the drag link.

Types of Steering Gears:

1. The Pit-man-arm type and
2. The Rack-and-Pinion type

Types of steering gears Box

1. Worm and sector steering gear.
2. Worm and roller steering gear.
3. Cam and double lever steering gear.
4. Worm and ball bearing nut steering gear.
5. Cam and roller steering gear.

6. Cam and peg steering gear.
7. Recirculating ball nut steering gear.
8. Rack and pinion steering gear.
9. Worm and nut steering gear

Worm and Sector

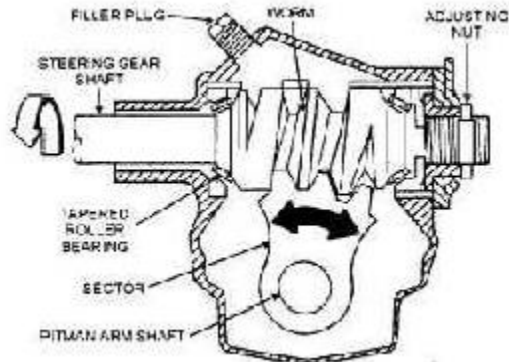

Worm and sector steering gear

- Worm and sector are based on the principle of transmitting the motion from the steering tube to the Pitman arm.
- The worm is attached with the inner column of the bearing block.
- The box is connected to the level of the plug with normal gear oil for lubrication of the steering gear.
- The worm at the end of the steering shaft meshes with a sector mounted on a sector shaft.
- When the steering wheel is rotates, then the worm will rotates.
- Then the sector will also be rotating the section shaft.
- So, the motion is transmitted to the wheel through the linkage.

Worm and Roller steering gear

- Worm and roller gear have two-toothed roller which are fastened to the cross shaft called as roller shaft or sector shaft.
- The threads of the worm gear are meshed with roller shaft at the end of the steering tube.
- When the worm shaft is turned by the steering tube, the roller will also be moved in an arc for rotating the roller shaft.
- The bearings are designed to resist both radial and end thrust.
- This system is used in Ford cars and American passenger cars.

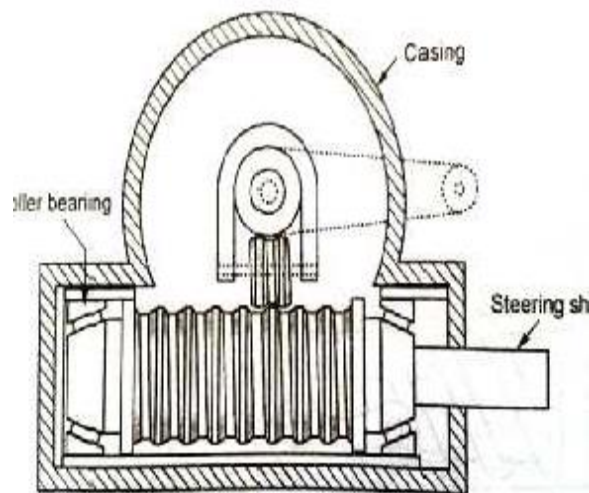

Worm and roller type steering gear

Cam and lever steering gear

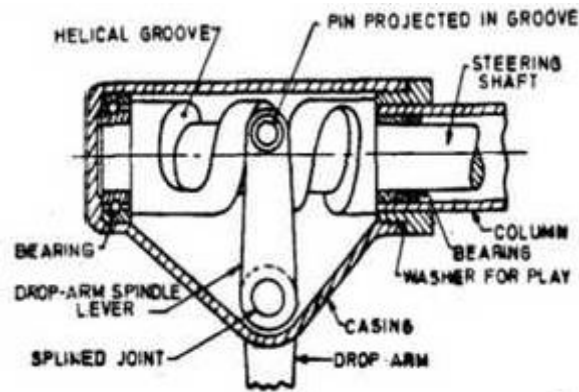

Cam and lever steering gear

- The cam is mounted at the lower end of the steering shaft. It consists of variable pitch worm.
- A twin lever carrying studs meshes in the groove of the cam.
- This arrangement provides minimum of friction when the contact is made between cam and a small stud.
- When the cam turns, the studs will also move in an arc. The cam is cylindrical in shape.

Worm and ball bearing nut steering gear

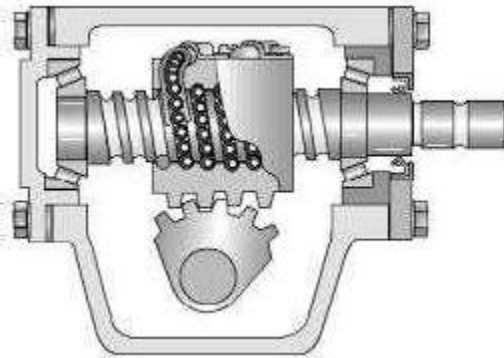

Worm and ball bearing nut steering gear

- In worm and ball bearing, the principle of transmitting the movement from the steering tube is worm and ball nut.
- A worm is connected at the lower end of the steering shaft whereas a ball nut is connected with worm.
- Steel balls are circulated for obtaining frictionless drive between the worm and nut.
- If the steering shaft is turned to left, the ball nut is moved downward by rolling action.
- The teeth of the ball bearing nut moving up or down the shaft will be moved on the sector teeth to force the cross shaft and rotate.

Cam and roller type steering gear

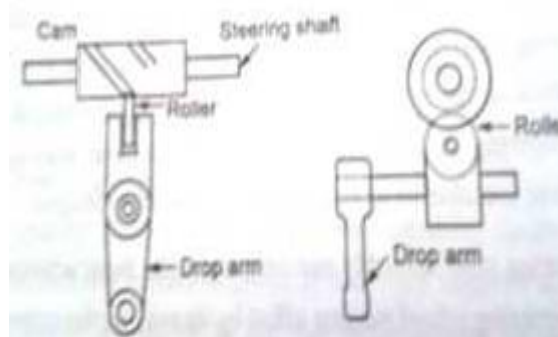

Cam and roller

Construction

- The cam and roller steering boxes are very efficient.
- The cam is carried by the steering shaft connected with rollers.
- The drop arm spindle carries the vee shaped roller.
- This spindle is carried by ball bearings in the casing.
- The meshing member contains the spiral grooves. The centre position of the pin supports the roller.

Working

- By moving the steering wheel and steering shaft, the cam is rotated.
- Due to this rotation, the roller is constrained to follow the helix of the groove.
- When the cam rotates, the roller is followed the cam and made the rocker shaft to rotate.
- The contour of the cam is properly designed to match with our aim.

CAM and PEG type

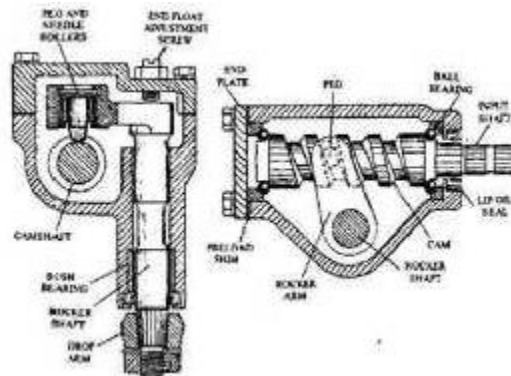

Cam and peg type gear

- The steering gear has a tapered peg in the rocker arm engaged with a special cam provided on the inner column.
- The peg is moved along the groove for rotating the rocker shaft by rotating the cam.
- An adjusting screw on the side cover is connected for governing the backlash and end float of the rocker shaft.
- The rocker arm is rotated with high efficiency cam and peg gear rotates by a peg in the bearings.

Recirculating ball system steering system:

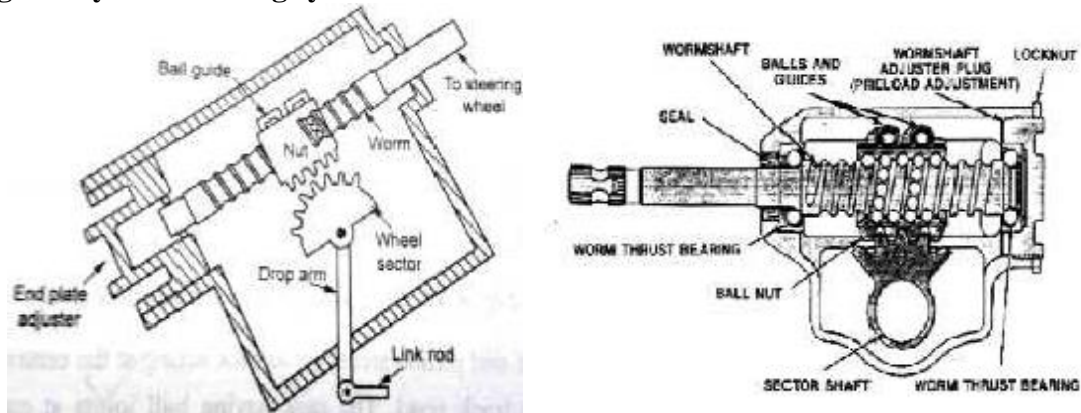

Recirculating ball type steering gear

Construction

- This type of gear was the most widely used steering gear at one time in Tata and Standard 20 vehicles.
- It consists of a worm at the end of steering rod, half nut and transfer tube containing the balls.

- The balls are fed back to the nut connected by half nut with the transfer tube.
- A worm and nut are placed at the end of the steering shaft. Steel balls are loaded between the sets of groove of worm and nut for recirculation.
- The nut has teeth on its circumference. These teeth are to be meshed with a toothed wheel.

Working

- When the driver turns the steering wheel, the two steel ball races will roll in the grooves and make the nut to travel along the length of the worm.
- The motion from the nut is transmitted to the wheel sector.

Advantage

- These balls reduce the friction and increase the efficiency of the mechanism to 90%.

Rack and Pinion

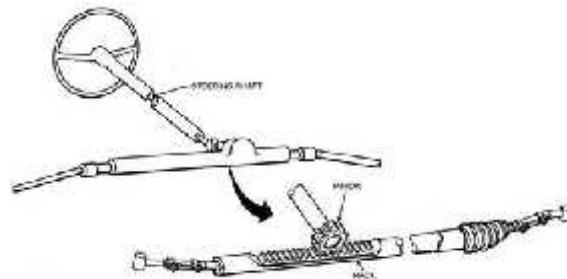

Rack and pinion

Construction

- This type of steering gear is mainly used in cars having independent front suspension.
- The pinion is mounted at the end of the steering shaft.
- A universal joint is connected at the bottom end of the steering shaft to mount the steering box centrally.
- A rack is engaged with the pinion. The rack reciprocates sideways to give lateral movement to the front wheels.
- Spring pads connected with the rack reduce the backlash between gears to a minimum.

Working

- The driver effort is transmitted to the front wheel through the steering wheel, to steering shaft and finally to the steering knuckle.
- The rack having ball joints at each end for allowing the rise and fall of the wheel is engaged with the pinion mounted at the end of the steering shaft.
- A rack is engaged with the pinion. The rack reciprocates sideways to give lateral movement to the front wheels.
- The backlash in rack is reduced to a minimum due to spring pads are placed below the rack.

Advantages

- The rack and pinion steering provides sufficiently a low gear reduction.
- It is also made suitable for heavier motor vehicles by power assisting.

Worm and Nut Gear

Construction

- These types of steering boxes are commonly used.
- Screw and nut gear has a phosphor-bronze or steel nut which is screwed on to a multi-start Acme thread.
- A single ball race provided at the top end of the rocker shaft carries the axial thrust of the column.
- At that time, the nut sliding in the housing supports the lower end.
- The screw is made to rotate freely on bearings.

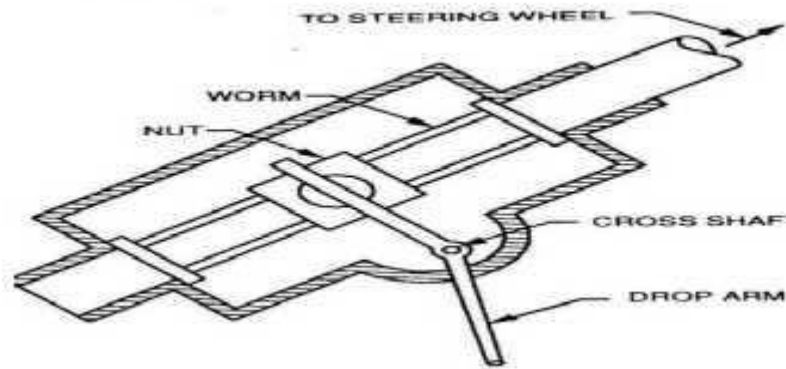

Worm and nut steering gear

Working

- A shaft connects the screw with the steering wheel.
- Therefore, as the screw is turned by rotating the steering wheel.
- The spindle is mounted on ball bearings. The drop arm is taken by this spindle at its outer end.
- The two arms of the spindle are attached to the nut by bronze pads.
- These pads are placed and made to rotate in the cylindrical recesses provided in the sides of the nut. Also these pads have parallel grooves to receive the arms of the spindle.
- The bronze pads cause the arms of the two armed spindles moving in circular path.

9. EXPLAIN THE POWER STEERING SYSTEM WITH NEAT SKETCH

Introduction

- Vehicle dynamic is an integral part of an automobile vehicle which is as important as the power train of a vehicle, as if we need a power train to run a vehicle we also need vehicle dynamics systems to keep the vehicle running with stability, as we know suspension system is the part of vehicle dynamics that provide surface contact along with the turning stability to the vehicle but let's just think, turning the direction by the vehicle.
- A steering system of an automobile is an integral part of vehicle dynamics of a vehicle in which a series of mechanical components having certain important angles comes together to steer the front wheels of the vehicle according to input provided by the passenger through steering wheel. And the power steering system is the advanced steering system in which the effort required to steer the front wheels of the vehicle side to side is reduced by using intermediate electric or hydraulic devices that multiplies the force applied by the driver through steering wheel in order to achieve smooth and quick directional change of the vehicle.
- Today all the 80% of the cars on road are equipped with the power steering system which has become the basic need of today's automobile.
- After the introduction of the power steering in 1903, it is found that the number of accidents on the road is decreased to the appreciable limit which in turn makes it the necessity in a 4 wheel drive.

Why do We Need Power Steering?

- As we have already discussed above a power steering decreases the steering efforts which is the need of a 4 wheel automobile vehicle so we need a power steering due to the following reasons
- **Quick response-** As the number of the vehicle on the road is increasing day by day and today almost 60% families of the world are having a 4 wheeler in their houses, with this increase in number of vehicles the danger of accidents on road is also increased, so to avoid this danger and to take quick turns required by the road conditions a quick response steering system is required in a 4 wheel vehicle.
- **Steering efforts** – If we drive old cars like Maruti Suzuki 800 , it is found that the steering wheel of the car feels very hard to rotate when the vehicle is going below 40 km/hr (above that the steering feels less hard)

which is found to cause fatigue to the driver while going on a long ride. So a vehicle should be equipped with a power steering system so that the steering effort required to steer the front wheels can be reduced.

- **Bump steer-** As we know the bumps of the road is reduced by the suspension system but as the steering system is directly attached to the wheel's hub some amount of bumps force is also transferred to the steering system which in turn tries to steer the vehicle against the will of the driver due to which a vehicle can lose its stability, though the bump steer can be controlled mechanically by providing optimum scrub radius (angle between the centre line of the wheel and the king-pin inclination of the knuckle) but the power steering controls it in a more effective manner.
- **Return ability-** after taking a turn it is found that the steering returns automatically to its original position which in turn automatically straightens the moving vehicle. A vehicle equipped with a power steering system provides better return ability to the steering system.

Types of Power Steering System

On the basis of the method used to multiply the steering force there are 3 types of power steering system that are-

1. **Hydraulic power steering system**
2. **Electro – hydraulic power steering system**
3. **Electronic power steering system**

Hydraulic Power Steering System

It is the type of power steering system in which hydraulic system having hydraulic pump driven by the engine and hydraulic cylinders, is used to multiply the steering wheel input force which in turn reduces the efforts required to steer the front wheels of the vehicle.

- A highly compressed hydraulic fluid is used inside the hydraulic cylinder that applies pressure on the steering gear.

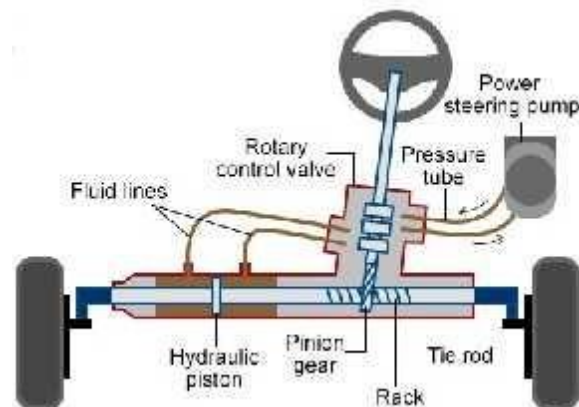

- In this type of power steering system as we discussed above the hydraulic force is used to multiply the steering input force in order to smoothen the steering of the front wheels, this hydraulic force is generated by a series of components that includes hydraulic cylinder, rotator hydraulic pump, hydraulic lines, highly compressed hydraulic fluid and a coupling mechanism that can couple this hydraulic system with rack of the steering system.
- When the driver provides input by rotating the steering wheel, the hydraulic pump driven by the engine starts pumping the highly compressed hydraulic fluid through lines.
- The hydraulic pressure produced by the pump enters the hydraulic cylinder which in turn applies pressure over the cylinder's piston.
- The piston which is under high pressure starts moving from one end to the another which in turn pushes the further fluid through lines, with this movement of piston the input force applied by the driver is multiplied several times.

- This high pressure fluid sent by the hydraulic cylinder then applies the pressure to the attached pinion through the coupling mechanism which in turn applies high force to the rack gear and the steering action in the front wheels takes place.

Important Components

The important parts of a power steering system are-

- 1. Steering mechanism-** Usually rack and pinion steering mechanism is used in power steering in which the rotational motion of the steering wheel is converted into the transverse motion of the wheels by a set of constantly meshed worm gears called rack that provide transverse motion and a pinion that provides rotational motion.
- 2. Linkages –** They are the mechanical constraints that provide relative motion between 2 components, the type of linkages used in power steering is the tie-roads that connects the rack to the knuckle of the wheel in order to transfer the transverse motion of the rack to the wheels.
- 3. Power device-** As we have already discussed above a force multiplying device (either hydraulic or hybrid or electric) is used to multiply the steering wheel force in order to reduce steering efforts. This device is attached with the pinion of the rack and pinion mechanism.
- 4. Steering wheel-** A round steering wheel is used inside a cockpit (operated by the driver) that provides the rotational steering input to the further steering devices in order to steer the vehicle.

Working of Power Steering System

The working of the power steering system differs with the difference in force multiplying devices used. so to understand the working of the power steering all the 3 methods must be discussed separately.

Hybrid or Semi Hydraulic Power Steering System

- It is the modified version of the hydraulic system in which the rotary hydraulic pump which is driven by the engine in hydraulic power steering system is replaced with the hydraulic pump which is driven by the electric motor.
- It is also called the hybrid power steering system due to the use of both hydraulic and electric components.
- In this type of power steering system the hydraulic pump driven by the engine from the hydraulic power steering system is replaced with electric pump which makes it more reliable, this is the only modification made rest the working of this system is same as the hydraulic power steering system mentioned above.



Electric Power Steering System

- It is the latest type of power steering system in which the hydraulic system from the hydraulic power steering is completely replaced with electric motors and electric sensors, instead of using hydraulic force, the motor driven by the vehicle's battery is used to apply force on the steering gear and torque provided by the motor is controlled by the sensors that detects the position of the steering column.
- The steering response of this system is quick and very effective that is why it is used in almost all the new cars today.

- This system is latest of all the steering system mentioned above in this type of steering system as we have already discussed the force multiplication is the function of the electric motor instead of hydraulic fluid and the working of this system is as follows-

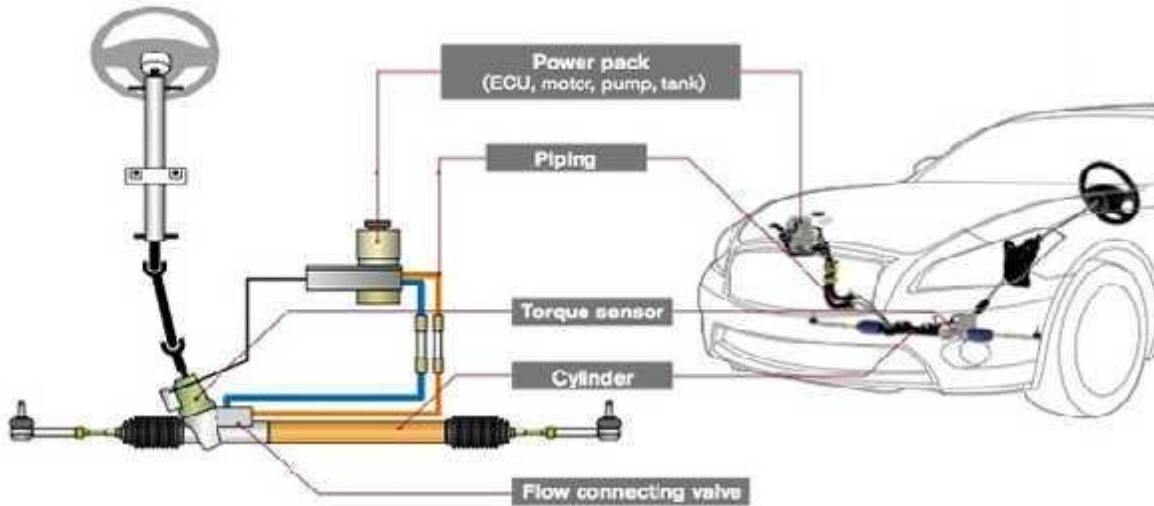

- When the driver gives input through the steering wheel the electronic sensors attached to the steering column reads the input and sent them to the electric control unit of the vehicle.
- The ECU of the vehicle analyses these inputs and sent the voltage signal to the electric motor placed at the end of the steering column whose gear is in constant mesh with the pinion gear.
- Due to these voltage signals sent by the ECU the motor which is driven by the battery of the vehicle starts and provides the particular torque according to the value of the voltage signals received
- After the motor starts the gear which is in constant mesh with the pinion gear starts transmitting the multiplied torque to the pinion gear which in turn applies this torque to the rack through which it is attached.
- With this torque applied by the pinion over rack, rack moves which in turn steer the front wheels (with the help of the tie rods attached) as per the requirement.

10. STEERING TROUBLE SHOOTING

1. Excessive Backlash in steering
2. Wander
3. Pulling to one side
4. Wheel wobble (low speed shimmy)
5. High speed shimmy
6. Wheel tramp
7. Excessive tyre wear
8. Hard steering
9. Slipping steering
10. Poor returnability

Excessive Backlash in steering

- Steering gear box e loose in chassis frame.
- Steering drop arm may be loose on splines.
- The ball joints may be loose or worm.
- Linkage not be proper, which may be done correctly
- Defective shock absorbers which have to be replaced.
- Low power steering fluid. (hydraulic)

Wander

- Tyres may be badly worn.
- The bearing of steering knuckle.
- The front wheel bearings maybe worn out.
- The amount of castor on the wheels may be less.
- The vehicle maybe simply overloaded at the rear.
- The toe-in maybe incorrect.
- U- bolts or the steering ear mountings maybe loose.
- Lack of lubrication.

Pulling to one side

- The tyre pressure maybe uneven.
- The uneven worn out tyres.
- The brakes may be dragging.
- The camber may have changed.
- The castor on the front wheels maybe uneven or incorrect.
- Alignment of front wheels maybe incorrect.
- The front wheel bearings maybe tight.
- The suspension spring maybe broken.
- The stiffness of the front springs may have become uneven with use.
- Spring tie bolts may have broken.
- Defective shock absorbers.

Wheel wobble (low speed shimmy)

- Tyres may have worn unevenly.
- Incorrect balance weights.
- The tyre pressure maybe uneven.
- The ball joints may have worn out.
- Steering gear or wheel bearings maybe loose.
- The stiffness of the spring maybe less.
- The camber maybe incorrect or uneven.
- The caster may have become excessive due to wear of bushes or damage to front suspension.

High speed shimmy

- Wheel rim may be buckled.
- Front tyres maybe having uneven pressure.
- The bearings of front wheels may have worn out or otherwise loose.
- Hydraulic shock absorber maybe faulty.
- The toe-in front wheels may not be correct.

Wheel tramp

- The tyre pressure in the wheels in the wheels maybe unequal.
- The wheel assembly may not be balanced dynamically.
- The front shock absorber maybe defective.
- Incorrect caster.

Excessive tyre wear

- Tyre pressure may not be incorrect.
- Excessive toe-in or toe-out.

- Excessive camber.
- The brakes maybe dragging.

Hard steering

- Tyre pressure maybe too low.
- Excessive caster.
- Excessive friction in the steering gear box or linkage or ball joints.
- Steering gear adjusted too tightly or binding condition in steering column.
- Incorrect wheel alignment.
- Defective power steering pump.
- Loose power steering pump belt.
- Incorrect power steering fluid level.

Slipping steering

- Incorrect power steering fluid level.
- Defective power steering pump.
- Loose power steering pump belt.
- Leaking power steering rack.
- Damaged steering rack mounts.

Poor returnability

- Tyre pressure maybe too low.
- Steering gear to column misalignment.
- Tight or frozen steering shaft bearings.
- Tight steering leakage.
- Steering gear maybe adjusted too tight.
- Front wheel alignment maybe incorrect.

SUSPENSION AND BRAKING SYSTEM

1. WHAT ARE THE OBJECTIVES AND COMPONENTS OF SUSPENSION SYSTEM? (OR) EXPLAIN IN DETAIL ABOUT SUSPENSION SYSTEM WITH NEAT SKETCHES. (OR) EXPLAIN THE DIFFERENT TYPES OF SUSPENSION SPRINGS WITH NEAT SKETCHES.

1. SUSPENSION INTRODUCTION

- Suspension system is the term given to the system of springs, shock absorbers and linkages that connects a vehicle to its wheels . It is basically cushion for passengers protects the luggage or any cargo and also itself from damage and wear.
- Sir **William Brush** is the father of suspension system in automobiles.
- Suspension is the term given to the system of springs, dampers (shock absorbers) and linkages that connects a vehicle to its wheels.
- Suspension systems serve a dual purpose – contributing to the
- car's handling and braking for good active safety and keeping
- vehicle occupants 'comfortable' and reasonably well isolated from
- road noise, bumps, and vibrations
- These goals are generally at odds, so the tuning of the suspension involves finding the right compromise. The suspension also protects the vehicle itself from damage and wear.
- The design of front and rear suspension of a car may be different from one another.
- So a suspension linkage system of some sort is needed to enable the wheel to move up & down vertically.

Objects of suspension:

- To prevent the road shocks from being transmitted to the vehicle components
- To safeguard the occupants from road shocks
- To preserve the stability of the vehicle in pitching or rolling, while in motion.

Purpose

The purpose of the suspension is to provide the vehicle with the following:

- A smooth ride
- Accurate steering
- Responsive handling
- Support the weight of a vehicle
- Maintain acceptable tire wear

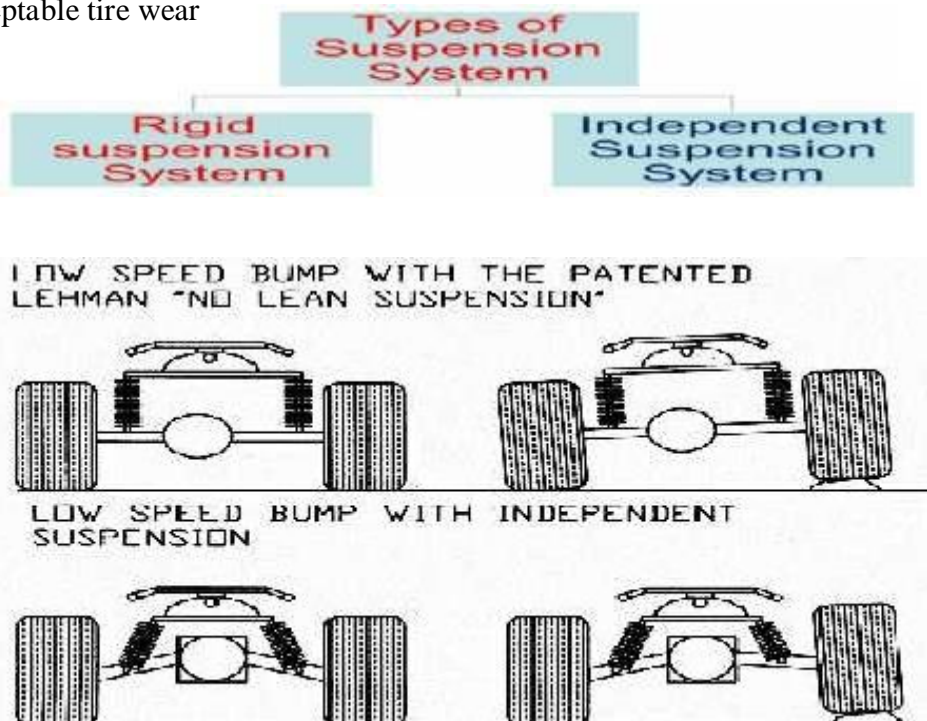

1. Non-independent/Rigid suspension has both right and left wheel attached to the same solid axle. When one wheel hits a bump in the road, its upward movement causes a slight tilt of the other wheel.

2. Independent suspension allows one wheel to move up and down with minimal effect to the other.

Coil spring is the most common type of spring found on modern vehicles.

Leaf springs are now limited to the rear of some cars.

Principle:

- When a tire hits an obstruction, there is a reaction force. The size of this reaction force depends on the unsprung mass at each wheel assembly.
- In general, the larger the ratio of sprung weight to unsprung weight, the less the body and vehicle occupants are affected by bumps, dips, and other surface imperfections such as small bridges. A large sprung weight to unsprung weight ratio can also impact vehicle control. No road is perfectly flat i.e. without irregularities. Even freshly paved highways have subtle imperfections that can interact with vehicle's wheels. These are the imperfections that apply forces on wheels.
- According to **Newton's law of motion** all forces have both magnitude and direction. A bump in the road causes the wheel to move up and down perpendicular to the road surface. The magnitude of course, depends on whether the wheel is striking a giant bump or a tiny speck. Thus, either the wheel experiences a vertical acceleration as it passes over an imperfection. The suspension of a car is actually part of the chassis, which comprises all of the important systems located beneath the car's body. These systems include:
 - ❖ Frame
 - ❖ Suspension system
 - ❖ Steering system
 - ❖ Tires or Wheels

Basic Considerations:

Vertical Loading: due to bump or pit on the road

Rolling: due to the centre of gravity of the vehicles is considerably above the ground, which causes the centrifugal force acts outwards on the C.G. of vehicle while taking the turns.

Brake Dip: on braking, the vehicle has a tendency to be lowered or to dip, which based on the C.G., wheel base and other suspension characteristics.

Side Thrust: Due to cornering, cross winds, cambering of the road etc.

Unsprung Weight: The weight of vehicle components between the suspension and the road surfaces, which includes rear axle assembly, steering knuckle, front axle, wheels, tyres and brakes. (Sprung weight means the weight supported by the vehicle suspension system includes the frame, body, engine and the entire transmission system.

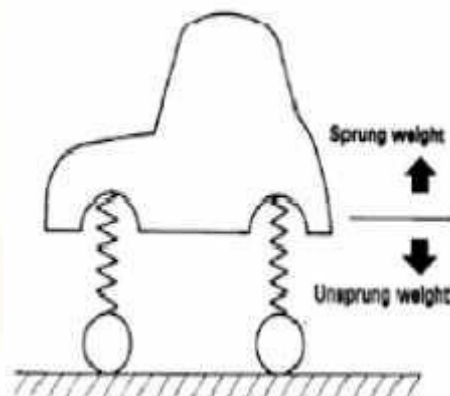
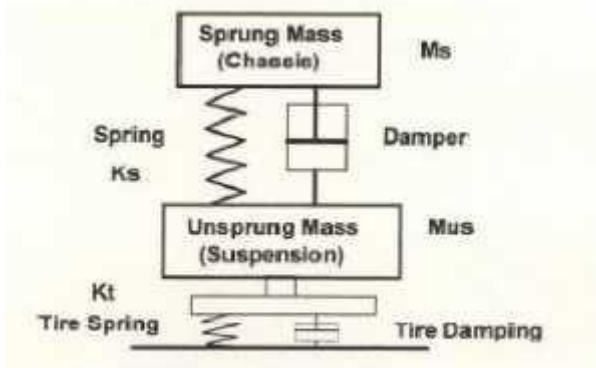

Miscellaneous: Pitching, Yawing, etc.

Functions of Suspension Springs:

- Storing the energy by deflection
- Expending the energy by rebounding.

Types of Suspension springs:

1. Steel Springs:

- Leaf spring
- Tapered Leaf Spring
- Coil Spring
- Torsion bar

2. Rubber Springs:

- Compression spring
- Compression shear spring
- Steel reinforced spring
- Progressive spring
- Face Shear spring
- Torsion shear spring

3. Plastic Spring

4. Air Spring

5. Hydraulic Spring

LEAF SPRINGS

- Leaf springs are formed by bending.
- They are made of long strips of steel.
- Each strip is named as Leaf.
- The long leaf is called Master Leaf, and it consists of eyes at its both ends.
- One end is fixed to the chassis frame, the other end is fixed to the shackle spring.
- The spring will get elongated during expansion and shortened during compression.
- This change in length of spring is compensated by the shackle.
- The U-bolt and clamps are located at the intermediate position of the spring.
- The bronze or rubber bushes are provided on both eyes on the master leaf.
- Originally called a *laminated* or *carriage spring*

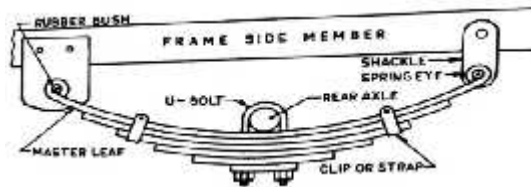

Leaf spring

Types of Leaf Springs

There are six types of leaf springs

- Full – elliptic type
- Semi – elliptic type
- Quarter – elliptic type
- Three Quarter – elliptic type
- Transverse Spring type
- Helper Spring type

Full – elliptic type

- The advantage of this type is the elimination of shackle and spring.
- The lubrication and wear frequently which are on of the main drawback of this type of springs.

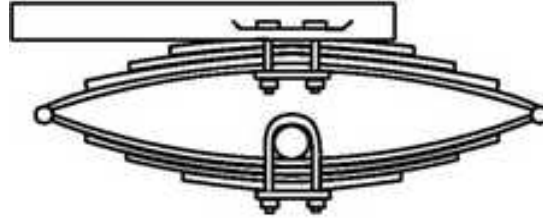

Full - elliptic

Semi – elliptic type

This type is more popular for rear suspension is used in 75% of cars.

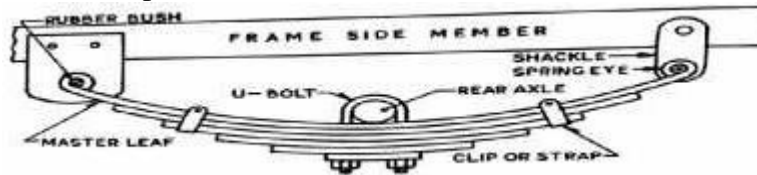

Semi- elliptic

Quarter – elliptic type

- This type is rarely used in now-a-days.
- It gives very less resistance in road shocks.

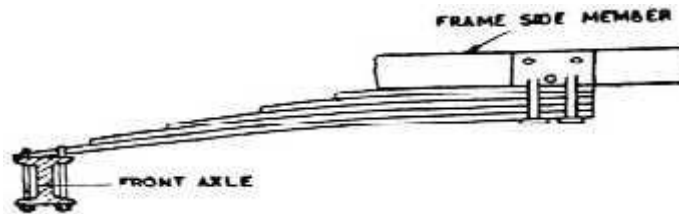

Quarter - elliptic

Three Quarters – elliptic type

- This type is rarely used in now-a-days.
- It is combination of quarters- elliptic and semi elliptic.
- It gives resistance, but occupies more space than other types.

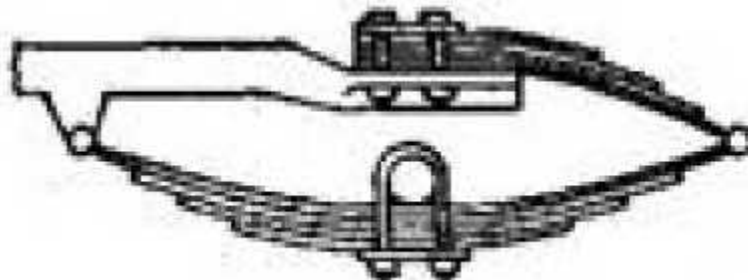

Three Quarters – elliptic

Transverse Spring type

- This type of spring is arranged transversely across the car instead of longitudinal direction.
- The transverse spring for front axle, this is bolted rigidly to the frame at the center and attached to the axle by means of shackle at both ends.

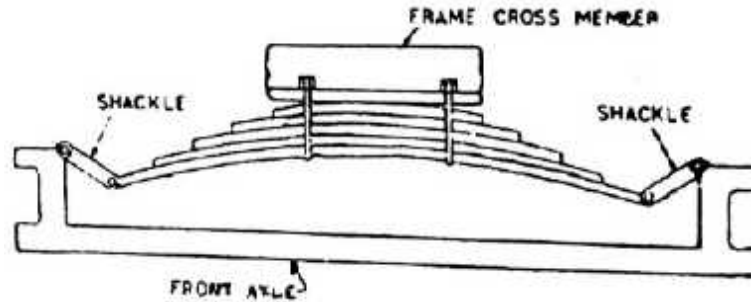

Transverse Spring

Helper Springs:

- The helper springs are used in heavy vehicles for rear suspension.
- When vehicle fully loaded the main spring as well as helper spring to come in action and absorb the road shocks.
- When the load of the vehicle is less, the helper spring will not act and the main spring only absorb the road shocks

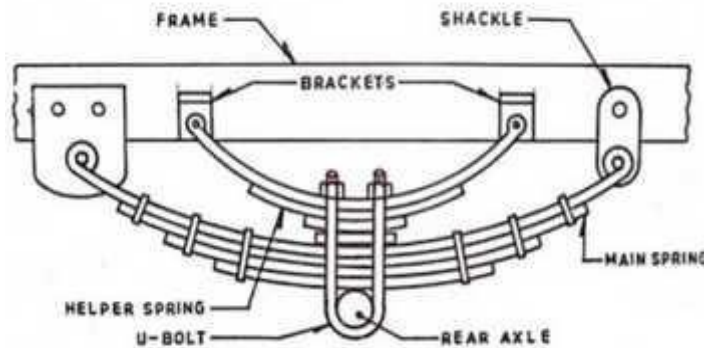

Helper Springs

Tapered Leaf Springs:

- Another name is Taperlite springs
- Advantages over conventional Leaf springs:
- Light weight (60%)
- No interleaf friction as in conventional leaf spring
- Absence of squeaking
- Stresses are lower and more uniform
- Occupy less space
- No collection of moisture between the leaves and hence no fretting fatigue.

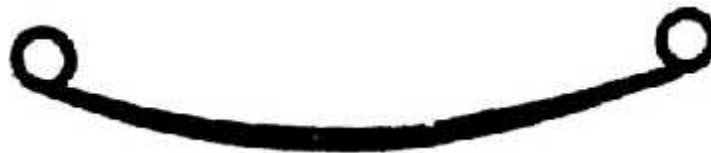

Tapered Leaf Spring

Coil Springs

- Used in independent suspension
- The energy stored per unit volume is almost double in the case of coil springs than the leaf springs
- No noise problems, No static friction causing harshness
- Takes shear as well as bending stresses.
- Cannot take torque reaction and side thrust.

- A helper coil spring is also sometimes used to provide stiffness against increasing load.

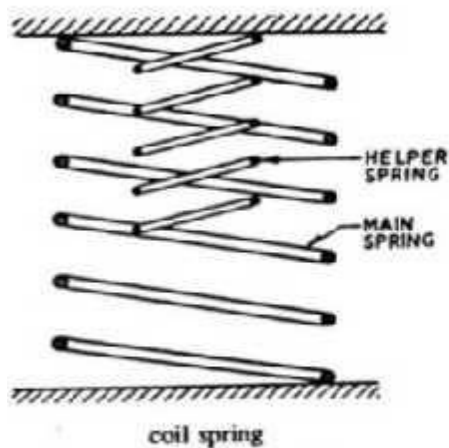

Coil spring

2. EXPLAIN THE WORKING OF TORSION BAR WITH NEAT SKETCH.

Torsion bar (Heat treated alloy spring steel)

- A rod acting in torsion and taking shear stresses only
- Used in independent suspension
- One end is fixed with frame, other at the end of the wheel arm and supported in bearing.
- The other end of the wheel arm is connected to the wheel hub
- When the wheel strikes a bump, it starts vibrating up and down, thus exerting torque on the torsion bar, which acts as a spring.
- Occupies less space
- Sometimes torsion tubes are used instead of the bars, the former being stiffer than the latter ones

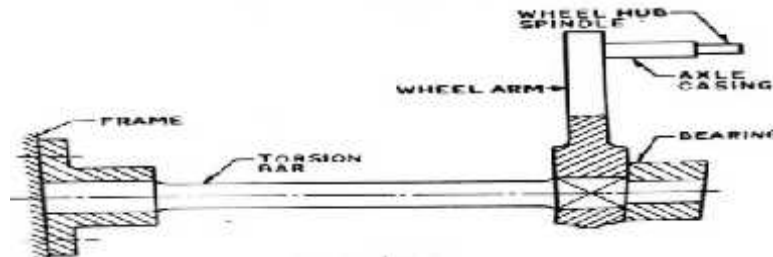

Torsion bar

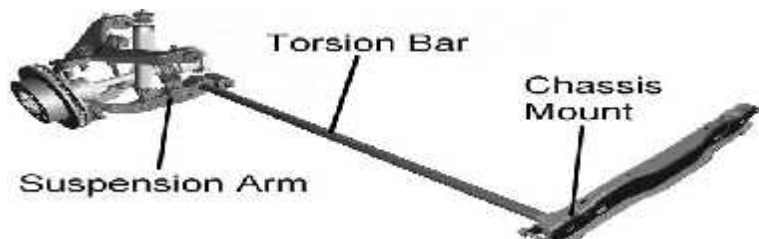

Components of torsion bar

Advantages

- The main advantages of a torsion bar suspension are soft ride due to elasticity of the bar, durability, easy adjustability of ride height, and small profile along the width of the vehicle.
- It takes up less of the vehicle's interior volume than [coil springs](#).

Disadvantages:

- Does not take the braking or driving thrust
- Absence of friction force, and hence of damping which is necessary to control the vibrations produced due to road shocks.

Rubber Springs:

Advantages:

- Store Greater energy per unit weight
- Excellent vibration damping properties
- Absence of squeaking
- Number of bearings is reduced considerably
- Rubber is more Reliable.



Compression spring



Compression shear spring



Steel reinforced spring



Progressive spring

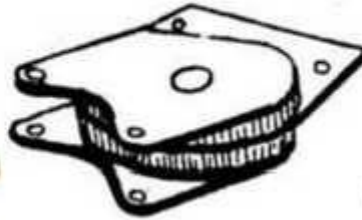

Face shear spring

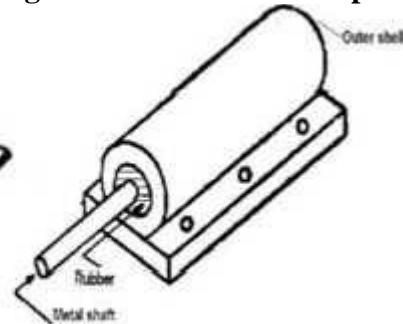

Torsional shear spring

Types of Rubber Springs:

1. **Compression Spring:** It is reliable, simple construction, resist occasional overload of large magnitude and large measure of inherent damping.
2. **Compression Shear Spring:** The load is carried partly by shear and partly by compression components in the rubber and large strains may be allowed in the rubber body. Fatigue properties are excellent
3. **Steel Reinforced Spring:** 'Eligos' spring consists of a steel helical spring bonded in a rubber body. Steel spring carries about 20% of the load, balance carried by rubber material.
4. **Progressive spring:** It has initially an exceedingly small rate which rises rapidly as the central cavity closes.
5. **Face Shear Spring:** consists of a thick disc of rubber having metal plates bonded to its flat surfaces, and axially precompressed. It operates by relative rotation of the plates about its axis thus loading the rubber partly in shear.

6. **Torsional Shear Spring:** consists of an inner metal shaft, tubular or solid, and an outer trough-like shell between which rubber body is bonded, the later being put under pressure by closing the trough with a riveted or spot welded bas plate. The spring operates by the rotation of the shaft about its own axis relative to the shell.

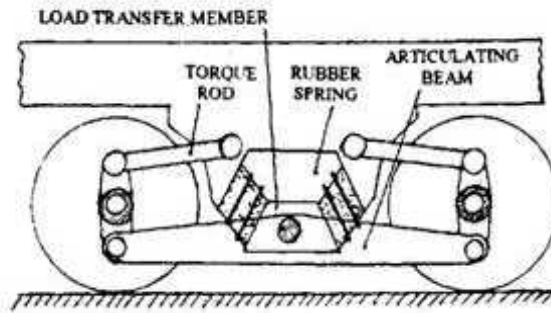

**3. EXPLAIN THE WORKING OF SHOCK ABSORBER WITH NEAT SKETCH. (OR)
EXPLAIN THE OPERATION OF A TELESCOPIC TYPE SHOCK ABSORBER WITH A SKETCH.
SHOCK ABSORBERS:**

- The shock absorbers are used to control the excessive spring vibrations (Control the amplitude and frequency of spring vibrations)
- Absorbs the energy of shock converted into vertical movement of the axle by providing damping and dissipating the same into heat.
- The shock absorbers are basically of two types: The friction type and hydraulic type. Friction type almost obsolete due to its non predictable damping characteristics.

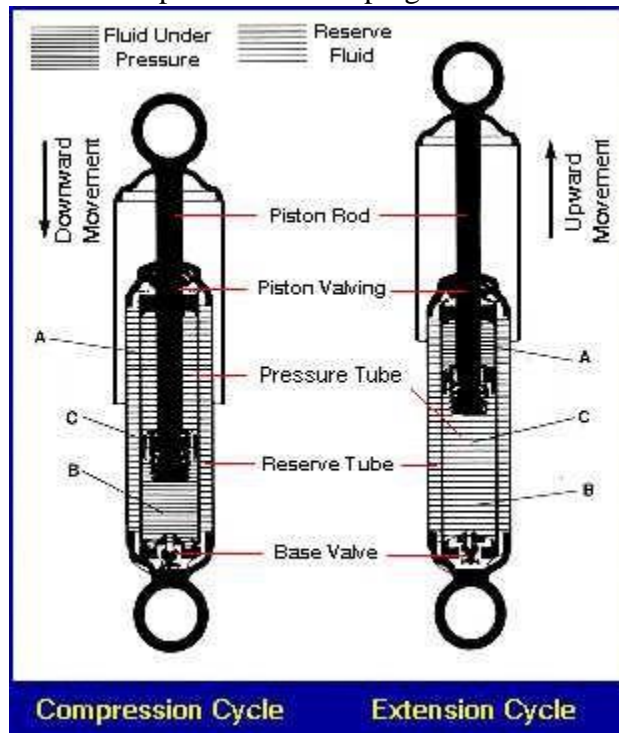

Shock absorber

A- Outer cylinder B- inner cylinder C- fluid

Principle of Hydraulic shock absorber: When a piston forces the fluid in a cylinder to pass through some hole, a high resistance to the movement of piston is developed which provides the damping effect. The dampening action of a hydraulic shock absorber comes from transferring oil, under pressure, through valves that restrict the oil flow. Resistance to motion is low when the piston moves slowly, and high when its velocity is

high. In hydraulic type the damping effect is proportional to the square of the speed. Therefore, for small vibrations, the damping is small and for larger vibrations, the damping becomes automatically more.

Telescopic Type Shock absorber:

Construction of Shock absorber:

- Rod G is attached to the 2 way valve A, while another similar two way valve B is attached at the lower space between cylinder C and tube D, which is connected to the space below the valve assembly B
- H is the gland in the head J and any fluid scrapped off by rod G is brought down into the annular space through the inclined passage shown in the head.
- The eye E is connected the axle, while the eye F is attached to the chasis frame.
- The fluid used in SA is a mixture of 60% transformer oil and 40% turbine oil.

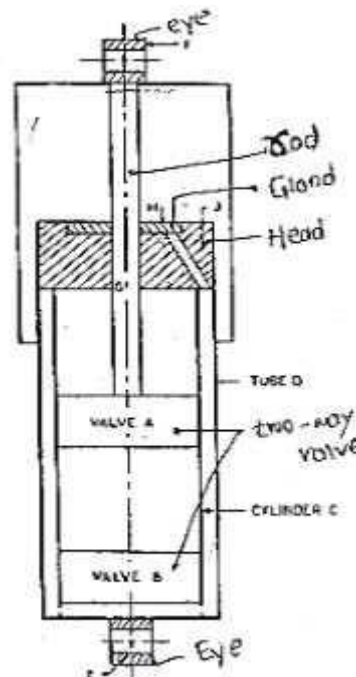

Telescopic absorber

Operation:

- Consider the car has come across a bump.
- Eye E would move up and thereby the fluid will pass from the lower side of valve assembly A to its upper side.
- Since the volume of the space above A is less by the volume of the rod G, the fluid will also exert its pressure on valve assembly B and go to the underside of valve B
- This passing of the fluid through valve openings provides the damping.
- Similarly for downward motion of the Eye E, the fluid will pass from the upper side of the valve assembly A to the lower side and also from the lower side of valve assembly B to its upper side.
- The construction of valve assembly A & B are shown in figure.
- When the pressure on the upper side become greater, the valve C opens against the force of the spring d and thereby allows the fluid to come down to the lower side.
- However when the pressure on the lower side becomes greater, the valve a is lifted against the force of star shaped spring b and the fluid passes up through the various openings.

Lever arm type shock absorber:

- Large deflections are possible in this type and its fade characteristics are better.
- This consists of two pistons operating in two adjacent chambers filled with oil and connected through holes which are covered or uncovered by means of a valve.
- The up and down movement of the lever arm due to road shocks causes one piston to move up and other down, thus causing the oil to flow through the oil holes which absorbs the energy of vibrations and causes their damping.



4. EXPLAIN THE WORKING OF FRONT INDEPENDENT SUSPENSION SYSTEM WITH NEAT SKETCH.

Independent Suspension:

- When rigid axle suspension is used in vehicle, which causes, the whole vehicle to tilt on one side, causing rough ride (wheel wobble) and road adhesion is also decreased.
- To avoid this the wheels are sprung independent of each other, so that tilting of one does not effect the other.

Advantages of Independent suspension:

- Lighter springs can be used (The elastic strain energy per unit spring weight store in a coil or torsion bar spring is greater than the leaf spring)
- Unsprung weight is reduced, which reduces the tyre scrub and hence increases tyre life.
- Softer springs can be used
- Steering geometry is not altered with spring deflection as in case of conventional rigid axle suspension.
- Engine and chasis frame can be placed relatively lower.

Types of Front wheel Independent suspension:

- Wishbone type or parallel link type
- Mac Pherson Strut Type
- Vertical Guide Type
- Trailing link Type
- 5 Swinging Half axle type.

Wishbone type suspension:

- Consists of upper and the lower wishbone arms (like chicken wishbone or letter V in shape) pivoted to the frame member.
- The spring is placed in between the lower wishbone and the underside of the cross member.
- The vehicle weight is transmitted from the body and cross member to the coil spring through which it goes to the lower wishbone member.
- The shock absorber is placed inside the coil spring and is attached to the cross member and to lower wishbone member.

- Due to the V shape, the wishbone is used to position the wheels and transmit the vehicle load to the springs and also resist acceleration, braking and cornering (side) forces.
- The upper arms are shorter in length than the lower ones, which helps to keep wheel track constant, thereby avoiding the tyre scrub thus minimizing tyre wear.
- However a small change in the camber angle does occur.
- Most popular independent suspension system.

Objects of Suspensions: Wishbone type suspension

- To prevent the road shocks from being transmitted to the vehicle components.
- To safeguard the occupants from road shocks.
- To preserve the stability of the vehicle in pitching or rolling while in motion.
- To provide required height to body structure as well as bear the torque and braking reaction.
- To keep the body perfectly in level while travelling over the uneven road.

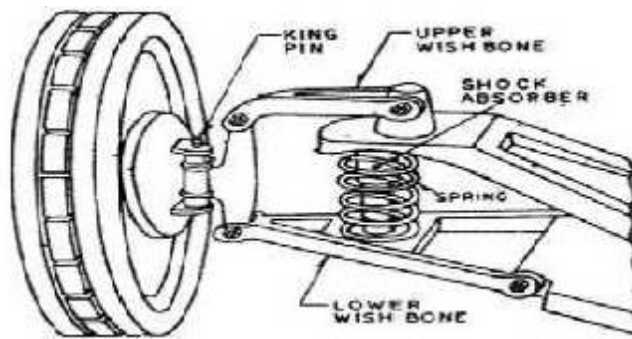

Wishbone type suspension

Mac Pherson Type of Suspension:

- Only lower wishbones are used.
- A strut containing shock absorber and the spring carries also the stub axle on which the wheel is mounted.
- The wishbone is hinged to the cross member and positions the wheel as well as resists accelerating, braking and side forces.
- Simpler than double wishbone type
- Lighter, keeping the unsprung weight lower.
- The camber also does not change when the wheel moves up and down.
- Gives the maximum room in the engine compartment.
- Commonly used on front wheel drive cars.
- When this system added with an anti-roll bar, which will give increased road safety, improved ride comfort and light and self stabilizing steering (car continues along its chosen line of travel when the brakes are applied even through the road surface may vary)

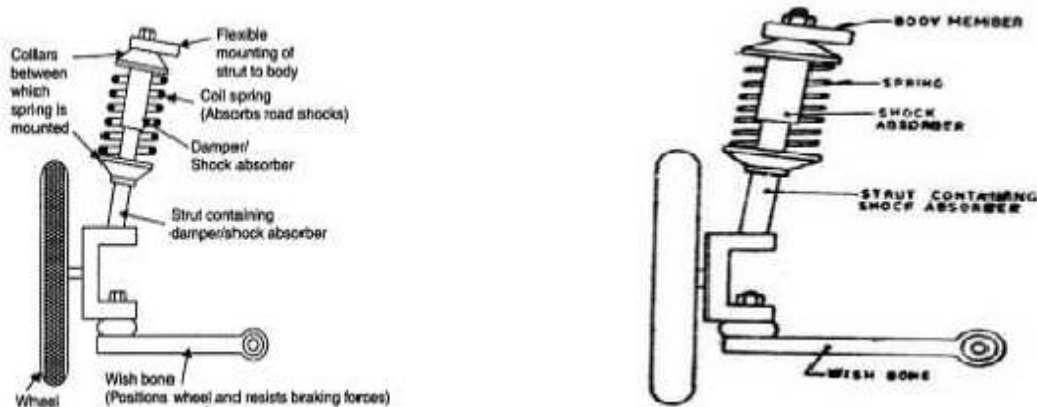

Advantages:

- Simple design
- Low manufacturing cost
- It is lighter than double wishbone type and hence unsprung weight is lower.
- It gives maximum room in the engine compartment and hence generally used in FWD vehicles.

Disadvantages:

- It requires substantial vertical space and a strong top mount.
- Geometric analysis shows it cannot allow vertical movement of the wheel without some degree of either camber angle change, sideways movement, or both.
- It is not generally considered to give as good handling as a double wishbone or multi-link suspension, because it allows the engineers less freedom to choose camber change and roll centre.
- It tends to transmit noise and vibration from the road directly into the body shell, giving higher noise levels and a "harsh" feeling to the ride compared with double wishbones

Vertical Guide Suspension:

- The king pin is attached directly to the cross member of the frame.
- It can slide up and down, corresponding to the up and down motion of the wheel, thus compressing or elongating the springs.
- The track, wheel base and wheel attitude remain unchanged.
- Main disadvantage: decreased stability.

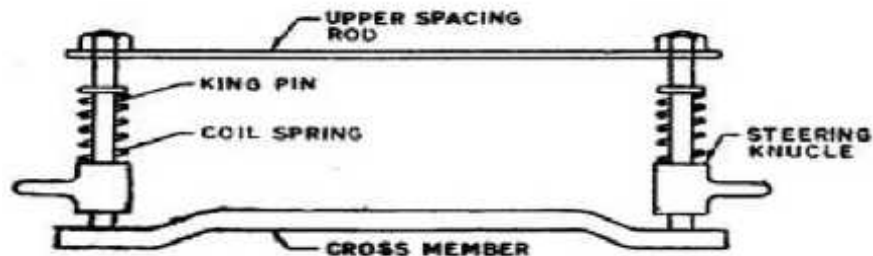

Trailing link Suspension:

- A coil spring is attached to the trailing link which itself is attached to the shaft carrying the wheel hub.
- When the wheel moves up and down, it winds and unwinds the spring.
- A torsion bar has also been used in certain designs in place of the coil springs.
- This system maintains the camber and wheel track constant, but distance between the front and rear wheels does change.

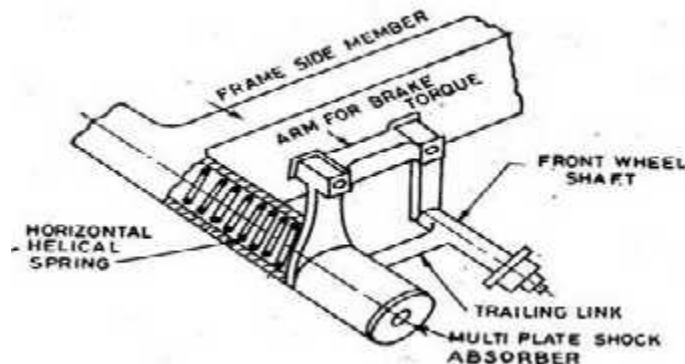

Swinging Half axle suspension:

- In this wheels are mounted rigidly on the half axles, which are pivoted on their ends to the chassis member at the middle of the car.

- The main disadvantage is that up and down movement of the wheel cause the camber angle to vary.

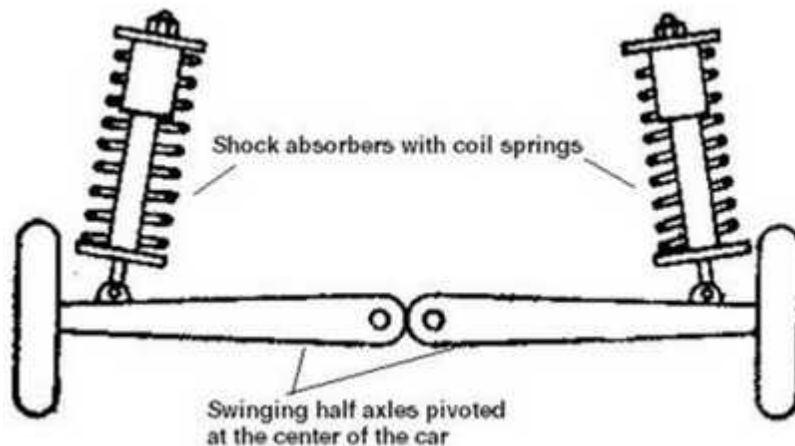

Rear Wheel (Live Axle) Independent Suspension:

- There is a considerable difficulty in the rear wheel springing if the power has to be transmitted to the rear wheels.
- Figure shows one method of rear wheel independent suspension.
- Universal couplings A and B keep the wheel vertical, while the sliding coupling C is required to maintain the wheel track constant, thereby avoiding scrubbing of the tyres. Example: de Dion Axle

Trailing Link Independent Rear Suspension:

- In this type the trailing links are pivoted at right angles to the longitudinal axis of the car and carry the rear wheels at their ends.
- A and B are the universal joints to keep the wheel track and the camber constant with the up and down movement of the wheels.
- S are the coil springs with shock absorbers mounted concentrically within them.
- The trailing links hold the wheels firmly and also sustain accelerating and braking forces.

Linked trailing arm rear suspension:

- In this the combined metal-rubber mountings respond softly on straight roads, increasing ride comfort.
- When cornering, they resist lateral force with a reliable stabilizing effect, even
- when the car is fully loaded

Disadvantages of Independent suspension system:

- The initial cost is high.
- Greater maintenance required because of larger number of bearings
- Misalignment of steering geometry with the wear of components, thus requiring more frequent attention.
- In the event of body roll, the wheels camber (tilt outwards in case of wishbone type and inwards in case of Mc Pherson Strut type), due to which cornering power is reduced.
- More rigid sub-frame or chassis frame required.
- Forces due to unbalanced wheels are more pronounced and transmitted easily to the steering wheel.

Stabilizer or Anti Roll device:

- When one road wheel is deflected more than the other, e.g., when it comes over a bump on the road, there is a tendency for the vehicle to roll

- To avoid this tendency, a stabilizer is used in the form of a torsion bar.
- The torsion bar C is fixed to springs A and B by means of two short rods D.
- The torsion bar is supported in two bearings E which are fixed to the frame.

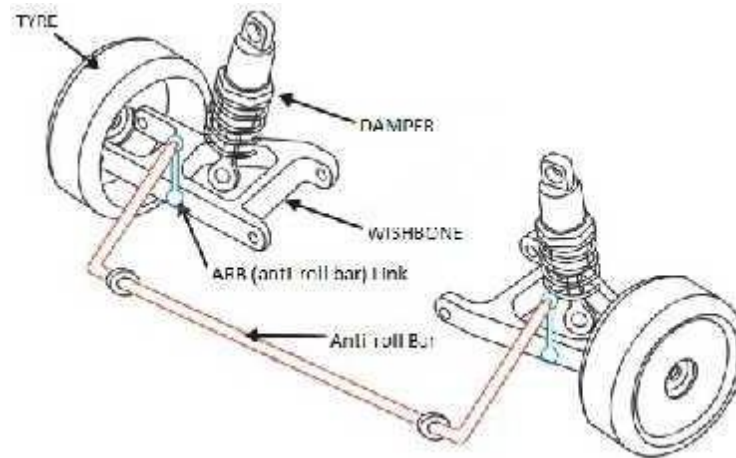

Working:

- When the car rolls out such that the nearer side in the figure moves up.
- That decrease load on spring A which caused the nearer rod D to move down.
- On the other hand the load on spring B is increased, thereby letting the farther rod D move up.
- Thus the bar C which is supported in bearings undergoes twisting.
- It is the resistance of the bar to twisting that counters the tendency of the car to roll out, thereby providing stability against lateral forces

Interconnected Suspension Systems:

- Air Suspension
- Hydroelastic Suspension
- Hydragas Units

Interconnected Suspension Systems: (Linked systems)

- The front and rear suspension units or else the units on the two sides of the automobile are connected together.
- The major advantage is that tendency of the vehicle to bounce, pitch or roll is reduced and a constant desirable attitude of the vehicle can be maintained.
- The simplest linked system is the air suspension.
- The other systems in current use are Hydrolastic suspension and Hydragas suspension systems.

5. EXPLAIN THE WORKING AIR SUSPENSION SYSTEM WITH NEAT SKETCH.

- These maintain a constant frequency of vibration whether the vehicle is laden or unladen.
- The stiffness of this system increases with the increase of deflection
- These maintain a constant from height from the road surface.

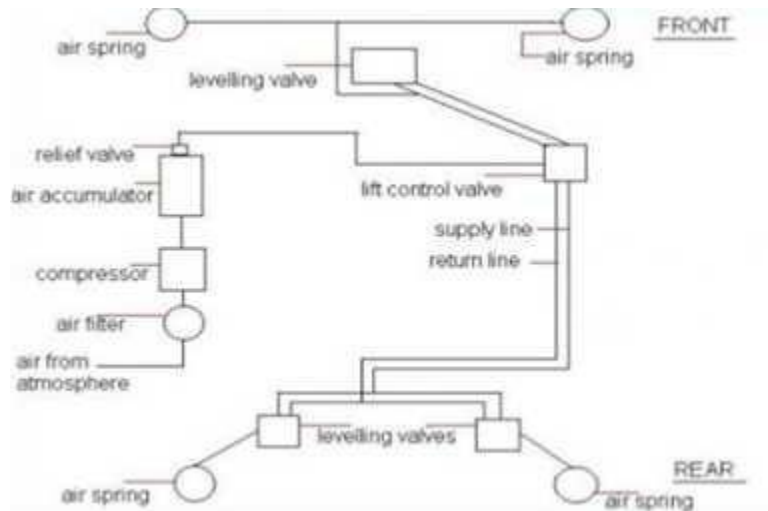

Layout of Air suspension system

Type of air springs:

a) Bellow type spring and

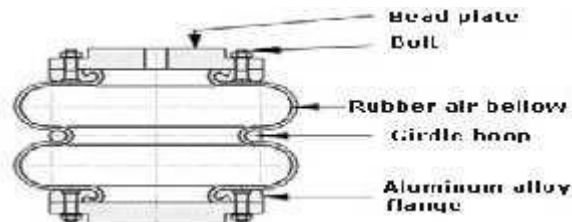

b) Piston type spring.

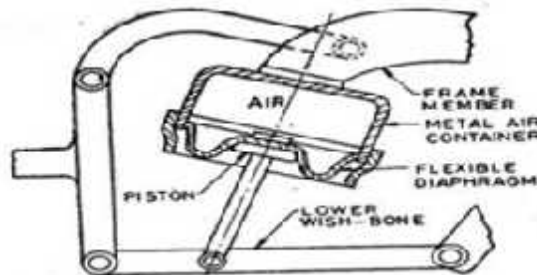

- Both have been employed in a wishbone type independent suspension system. The four air springs, which may be either the bellows type or the piston type are mounted on the same position where generally the coil springs are mounted.
- An air compressor takes the atmospheric air through a filter and compresses it to a pressure of about 240 MPa, at which pressure the air in the accumulator tank is maintained, which is also provided with a safety relief valve,
- This high pressure air goes through the lift control valve and the leveling valves, to the air springs.
- Each air bag of air spring is filled with compressed air and supports the weight of the vehicle.
- The air spring is placed between the chassis from and the axle beam.
- As the load is applied to the frame, the air bags get compressed, actuating the leveling valve.
- Air from the tank fills the compressed air bags and hence raises the level of the frame.
- The supply of air is automatically cut as soon as the frame reaches a predetermined level.
- The air from the air bag gets released as soon as the load on the chassis frame decreases, which is again done by the leveling valve.

Hydro elastic Suspension:

- Rubber springs actuated by hydraulic pressure.
- Each wheel has its own unit.
- The energy released by rubber springs is less than the energy imparted during bumps. Rubber gives good damping characteristics.
- The unit is attached between the frame and the axle.
- The front and the rear units are connected by pipes through which the fluid flows.
- When the road wheels encounter a bump, the piston of the hydro elastic unit moves upwards pushing the diaphragm.
- The fluid between the separator plate and diaphragm gets compressed and passes to the rear units through a two-way valve.
- The resistance of this valve provides the damping effect.
- The fluid pressure, in turn pushes the diaphragm of the rear suspension units, raising the rear end.
- Thus the level of the frame from the road surface is maintained.
- After the car has passed the bump, the fluid returns from the rear units to the front, restoring the original position.
- Similarly, when the rear wheels meet a bump, the front portion of the car is raised up.

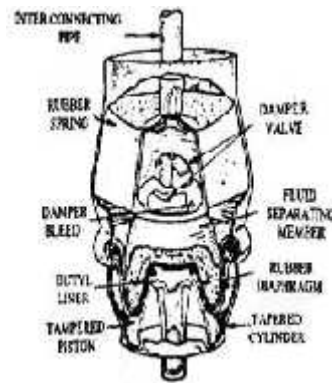

Hydragas Suspension Units:

- Commonly known as hydro-pneumatic suspension units
- These providing both damping and self leveling effect.
- Each wheel has a separate unit, the piston of the unit being attached to the centre of the suspension arm.
- The suspension arm links each wheel to the chassis frame
- The unit consists of a metallic spherical casing which is in two halves.
- The upper half contains nitrogen under pressure above the diaphragm.
- Below the diaphragm is a hydraulic cylinder full of hydraulic fluid.
- A piston slides inside the hydraulic cylinder and is connected to a push rod.
- The end of the push rod is pivoted to the suspension arm which links each wheel to the frame.
- A damper in the form of a valve is located at the top of the hydraulic cylinder.
- The fluid is kept in a tank the flow being controlled by a slide valve.
- The displacer chamber is sealed at its lower end by a load absorbing nylon reinforced rubber diaphragm (*piston diaphragm*) which rolls between the conical piston and the tapered displacer chamber skirt as the suspension deflects up and down when the wheels pass over any irregularities on the road surface.
- Within the spherical chamber is a butyl-rubber diaphragm (*separator diaphragm*) which separates the sphere into nitrogen charged (17.5 bars) upper region (the spring media) which is sealed for life, and the lower region which is filled with fluid.
- Initially fluid is pumped into the displacer chamber until it reaches the nitrogen charging pressure.

- Then it will compress and lift the separator diaphragm off the bottom of the sphere. Since the gas and fluid pressures are equal, the separator diaphragm is not subjected to heavy loads, in fact it only functions as a flexible wall to keep the gas and fluid apart.
- A water based fluid containing 50% industrial alcohol and a small percentage of anti-corrosion additive is pumped into the system to a pressure of 23 bars with the car in an un-laden state, this being the condition in which the car's body to ground height is checked.
- One advantage in using the rolling diaphragm type of displacer is that a water based fluid can be utilized as opposed to oil which would not have such stable viscosity characteristics.
- The effective area of the piston compressing the fluid is that projected area of the displacer diaphragm which is not supported by the internal tapered skirt of the displacer chamber.
- Therefore, as load on the displacer piston increases, and the piston is pushed further into the chamber, less of the displacer diaphragm will be supported by the chamber's skirt and more will form part of the projected effective piston area.
- The consequence of the diaphragm piston pushing up within the displacer chamber is that the load bearing area of the piston is increased due to the diaphragm rolling away from its supporting tapered chamber skirt.
- As a result the resistance offered by the fluid against the upward movement of the piston rises.
- In other words, due to the tapered chamber's skirt, the spring rate (stiffness) increases in proportion to the spring's deflection.
- The progressive action of the rubber valve between the two chambers provides for a measure of damping which slows down bump and rebound movements caused by the impact of the tyre on very bumpy roads.

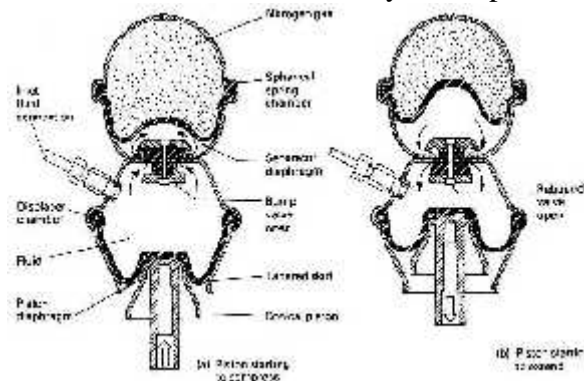

6. EXPLAIN THE MECHANICAL BRAKE SYSTEM WITH NEAT SKETCH. DRUM BRAKES WORK

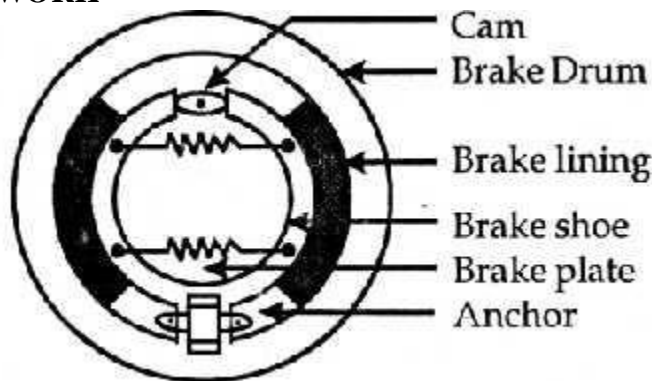

Mechanical drum Brake

- This internal expanding type of brake contains two shoes that are attached to a back-plate and are fixed to a stub axle or axle tube. The section of each shoe is of "T" shape.

- A friction lining is riveted or bonded to the outer face of the shoe. A drive is fitted at one end of the shoe so that the shoe expands when the brake pedal is applied. In a simple brake a cam is used as a shoe expander, but modern systems for cars use hydraulically operated pistons for shoe expansion.
- The shoe anchor is rigidly attached to the back-plate and takes the form of a large pin that passes through the shoes, or housing. The shoes butt against the anchor. Springs pull the brake shoes on the back-plate and also return the shoes to the 'off position after the brake has been applied.
- In some layouts separate springs execute the retention and return functions. The inner cylindrical surface of the cast iron drum is made smooth on to which the brake linings rub. The drum is generally fixed to the hub flange using counter-sunk screws and secured by the wheel nuts.
- It is necessary to adjust excessive clearance due to wear of the friction facing, so that they are always positioned very close to the drum. This is carried out either manually adjusting the brakes periodically, or having an automatic adjuster that continually sets the shoes.

Advantages of Drum brake system:

- Simple design.
- Fewer parts.
- Easy & cheaper to manufacture.
- Low maintenance cost.
- Comparatively longer life.

Disadvantages of Drum Brake system:

- Low braking force compared to Discs.
- Brakes 'fade' when the driver applies them for a prolonged time.
- The brake shoe lining made of asbestos is harmful to humans.
- When wet, the braking grip reduces considerably.
- Non-asbestos linings catch moisture; causing the brakes to grab suddenly.

MECHANICAL DISC BRAKE

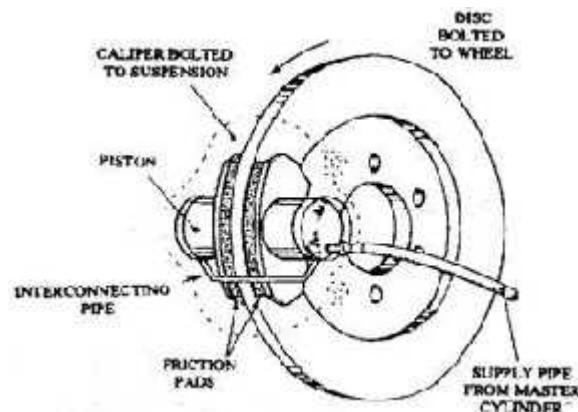

Mechanical Disc brake

- One problem with drum brakes is fade and to minimize this problem the disc brake was developed. It uses an exposed disc that is attached to the hub flange. The two friction pads are pressed on to this disc to provide braking action. The pads are actuated by hydraulic pistons placed in cylinders formed in a caliper, which is secured to a fixed part of the axle.
- The hydraulic pressure forces the friction pads against the rotating cast iron disc. Consequently, the disc motion is retarded and heat generated from the energy of motion is conducted to the disc.
- Since a large part of the disc is exposed to the air, heat is easily dissipated, so that the brake can be used continuously for long periods before serious fade occurs. In this layout the friction pads move at a right angle to the disc, so that any drop in the friction value does not affect the force applied to the pad.

- For the application of a disc brake, a greater pedal pressure is necessary to produce a given retardation than that required for a drum brake. Adjustment of pad wear is automatic on a disc brake. In this brake system the pads can also be inspected easily and in the absence of corrosion, the pads can be renewed easily.

Advantages

- It is lighter than drum brakes.
- It has better cooling (because the braking surface is directly exposed to the air)
- It offers better resistance to fade.
- It provides uniform pressure distribution
- Replacement of brake pads is easy.
- By design they are self-adjusting brakes.

Disadvantages

- It is costlier than drum brakes.
- Higher pedal pressure is required for stopping the vehicle. This brake system is installed with vacuum booster.
- No servo action is present.
- It is difficult to attach a suitable parking attachment.

HYDRAULIC DRUM BRAKE

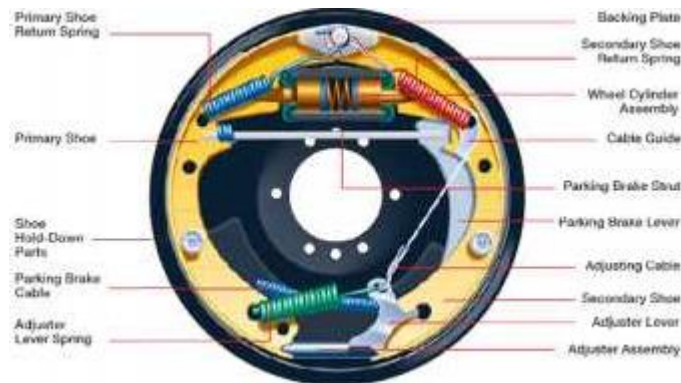

Hydraulic disc brake

- The whole assembly of the drum brake is fitted to the back plate of the wheel. The back plate remains stationary and it does not rotate with the wheel.

1. Brake Drum:

- It is a round cast iron housing which is used to stop the vehicle with the help of brake shoe. The drum brake is bolted to the hub of the wheel. It rotates with the hub.

2. Brake Shoe:

- It is the frictional part of the drum brake, without it the working of the brake is not possible. The brake shoe has brake lining at its outer curve. It is the brake lining which makes contact with brake drum during the stopping of the vehicle. It is of two types

(i) **Primary Brake Shoe:** The shoe having large lining material is called as primary shoe.

(ii) **Secondary brake shoe:** The shoe with small lining material is called secondary shoe.

3. Wheel Cylinder:

- It is used to force the brake shoe outward to apply the brake. The wheel cylinder is connected to the master cylinder. It contains piston which moves outward when brake is applied and forces the brake shoe towards inner surface of the drum.

4. Return or Retracting Spring:

- It is used to retract the brake shoe after brake is applied. Two return springs are there in drum brake, one for the primary shoe and other one is for secondary shoe.

5. Self Adjuster:

- It maintains the minimum gap between the brake shoe and drum so that they do not contact each other when pedal is not pressed. In the case if the brake lining wear out, and gap increases in between the shoe and drum, It can be adjusted again to maintain the gap between shoe and drum inner surface. once it is adjusted it maintains the same gap during the brake working by itself.

Working Principle

- The brake shoe is allowed to expand in both the direction. As the brake lining of shoe touches the inner surface of the drum, friction is generated in between the brake shoe and drum and stops the vehicle from moving.

Working of Drum Brakes

- As the brake pedal is pressed, it compresses the fluid in the master cylinder and allows the piston of the wheel cylinder to expand outward.
- The outward motion of the piston of wheel cylinder forces the brake shoe outward against the brake drum.
- As the brake shoe lining touches the inner surface of the drum, and due to the friction generated in between the brake shoe and drum, the motion of the wheel reduces and vehicle stops.
- As the force is removed from the brake pedal, the retracting springs draws the brake shoe inward and the contact between the friction lining and drum ended. Now again the brake is ready to apply.
- A self adjusting screw is present at the bottom, which is used to maintain a minimum gap between the drum and brake shoe. When the lining of the brake shoe is wear out than the gap between the drum and brake shoe increases, at that time the adjuster is adjusted again to maintain the minimum gap.

Advantages

- They are self energizing braking system. It means they are designed to operate by itself.
- It is cheaper than the disc braking system.

Disadvantages

- **Heating problem:** Since the friction area is totally covered by lining, so heat is developed during the friction is not allowed to go out in the atmosphere. This may reduces the braking efficiency of the vehicle.
- The drum brakes will not work properly if it gets wet in water. This is because water takes longer time to come out from the drum. the water reduces the friction in between the brake lining and drum. In this article we have learnt about how drum brakes works and its main parts, working principle with advantages and disadvantages. If you like this article than don't forget to share.

HYDRAULIC DISC BRAKE

- Brakes are very crucial for stopping a vehicle. Without brakes it is impossible to drive a car or any vehicle. Brakes are of different types and according to the requirement the types of brakes are chosen for the application. Here we will discuss about Disc brake – main components, working, advantages and disadvantages with application.

Main Components of Disc brake

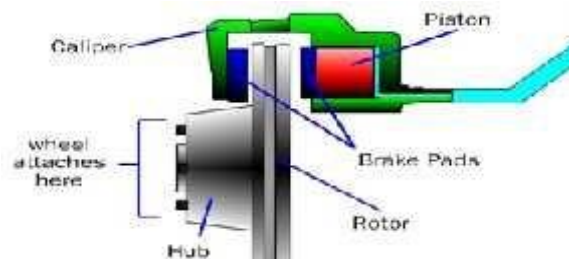

1. **Wheel Hub:** The disc rotor is attached to the wheel hub and it rotates with it. The wheel of the vehicle is bolted to the wheel hub.

2. Caliper Assembly:

The caliper assembly consist of

(i) **Brake pad:** It makes contact with the rotor disc and due to the friction between the brake pad and rotor disc the vehicle speed reduces and it stops.

(ii) **Caliper bracket**

(iii) **Caliper frame**

(iv) **Piston:** It applies the brake force on the brake pads when brake lever is pressed.

(v) **Slider pin:** It is the sliding pin which slides in the hole when brake is applied.

(vi) **Dust boots:** It prevents the entry of dust into the caliper pin or slider pin hole.

3. Disc Rotor: It is the rotating part of disc brake. When brakes are applied, a lot of heat is generated which can decrease the braking efficiency, so the rotor has drilled vent holes on it which dissipates the heat.

Working Principle

The working of a disc brake is based on Pascal law.

Working

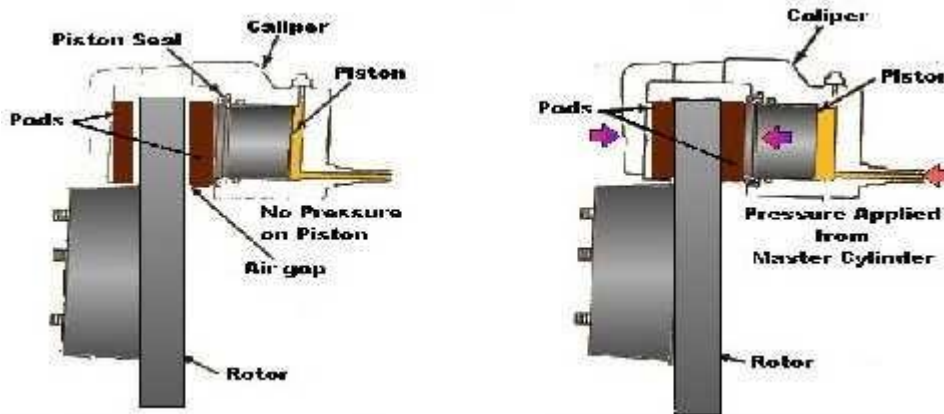

1. When brake pedal is pressed, the high pressure fluid from the master cylinder pushes the piston outward.
2. The piston pushes the brake pad against the rotating disc.
3. As the inner brake pad touches rotor, the fluid pressure exerts further force and the caliper moves inward and pulls the outward brake pad towards the rotating disc and it touches the disc.
4. Now both the brake pads are pushes the rotating disc, a large amount of friction is generated in between the pads and rotating disc and slows down the vehicle and finally let it stop.
5. When brake pad is released, the piston moves inward, the brake pad away from the rotating disc. And the vehicle again starts to move.

Advantages

- It is lighter than drum brakes.
- It has better cooling (because the braking surface is directly exposed to the air)
- It offers better resistance to fade.
- It provides uniform pressure distribution
- Replacement of brake pads is easy.
- By design they are self-adjusting brakes.

Disadvantages

- It is costlier than drum brakes.
- Higher pedal pressure is required for stopping the vehicle. This brake system is installed with vacuum booster.
- No servo action is present.
- It is difficult to attach a suitable parking attachment.

Application

Disc brakes are mostly used in motorcycles and cars.

7. EXPLAIN THE WORKING PRINCIPLES OF HYDRAULIC BRAKE SYSTEM WITH NEAT SKETCH

Hydraulic Braking System

Introduction

- Hydraulic braking system is a type of braking system in which unlike mechanical braking system, hydraulic fluid is used to transmit the brake pedal or brake lever force from the brake pedal or brake lever to the final drum shoes or disc caliper in order to achieve braking.
- In this type of braking system the mechanical force transmitted by the driver on the brake pedal is converted into the hydraulic pressure by a device known as master cylinder and then this hydraulic pressure is sent to the final drum or disc caliper in order to stop or de-accelerate the vehicle.

Why We Need Hydraulic Braking System

- As the braking of an automobile vehicle is a very crucial safety part so the responses from the brake pedal to the final braking must be very quick which was a failure of a mechanical type braking system and is very well achieved by the hydraulic braking system which provides quick braking.
- The brake force generated by hydraulic braking system is very high as compared to the mechanical braking which is a very important factor for today's super and hyper series of vehicles.
- Frictional wear and tear in case of mechanical braking system was very high due to the involvement of many moving parts, which is very well reduced to the optimum level with the introduction of hydraulic braking system which has very less moving parts as compared to the mechanical one.
- Brake failure chances in case of hydraulic braking system are very less as compared to the mechanical system due to direct connection between the actuator (brake pedal or lever) and the brake disc or drum.
- Design complexity in case of mechanical braking was very high which is reduced with the introduction of hydraulic braking system which has simple and easily assembled design.
- The maintenance in case of mechanical braking system was high due to the involvement of complex and more number of member which is not a problem with the hydraulic braking system as it has simple design with less moving parts.

Types

Hydraulic braking system are classified on 2 basis-

1. On the basis of frictional contact mechanism- On this basis, hydraulic brakes are of 2 types –

- (i) Drum brake or internal expanding hydraulic brakes.
- (ii) Disc brakes or external contracting hydraulic brakes.

2. On the basis of brake force distribution- on this basis, hydraulic brakes are of 2 types-

- (i) **Single acting hydraulic brakes**
- (ii) **Dual acting hydraulic brakes**

We have already familiar with these terms from our last article on types of braking so let's just study about their construction and working.

Constructional Details

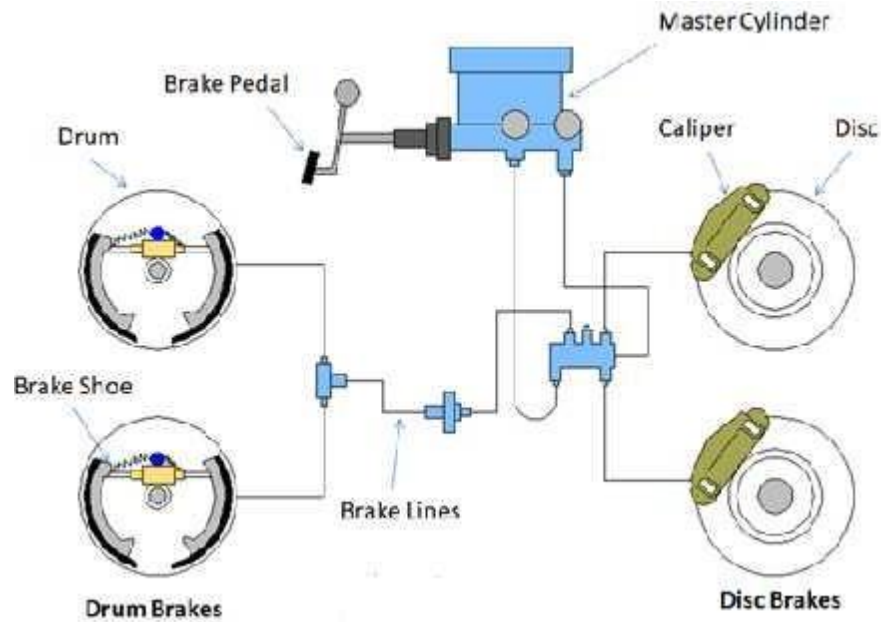

Hydraulic Brake system

1. Drum Hydraulic Brake or Internal Expanding Hydraulic Brakes-

In drum hydraulic braking system the parts involved are-

- **Brake pedal or brake lever-** In hydraulic braking system same as other braking brake pedal or brake lever is required by the driver to apply braking, this brake pedal or brake lever is attached with the master cylinder through mechanical rod or connecting rod.
- **Master cylinder-** It is the simple cylinder and piston arrangement (refer to article on master cylinder) which converts the mechanical force from the brake pedal into the hydraulic pressure.

The brake pedal is connected with the master cylinder's piston in such a fashion that the movement of pedal causes to and fro motion of the piston inside the master cylinder.

- **Brake fluid reservoir** – It is the simple reservoir tank containing brake fluid which is connected to the master cylinder with the help of brake hose.
- **Brake lines-** They are the hollow high pressure metal tube that connects the master cylinder with the drum cylinder inside these brake lines high pressure brake fluid from the master cylinder flows which is responsible for further brake actuation.
- **Drum cylinder-** It is the another cylinder fitted inside the drum of the drum brakes and is connected with the brake shoes , the high pressure brake fluid from the brake lines comes to this cylinder.
- **Brake drum (refer to article on drum brake)** – It is housing of drum cylinder , brake shoes and spring , the outer part of the drum rotates with the wheel and inner part consisting the brake shoe and cylinder remains stationary.

2. Disc Hydraulic Brakes or External Contracting Hydraulic Brakes-

Disc hydraulic parts and drum hydraulic brake parts are almost same that are

- **Brake pedal or brake lever-** Exactly same as drum brakes mentioned above.
- **Master cylinder-** Same as drum brakes
- **Brake fluid reservoir-** Same as drum brake.
- **Brake lines** – Same as drum brake but here they connect the master cylinder with the disc calliper cylinder.

- **Disc rotor-** It is the metallic disc fitted with the wheel hub in such a fashion that it rotates with the wheel of a vehicle moreover disc rotor is the surface that make frictional contact with the brake shoe in order to stop or de accelerate the vehicle.
- **Disc caliper-** It is a small stationary component fitted over a disc just like a clamp, inside which there is a housing of brake shoes and hydraulic cylinder, when the brakes are applied the brake shoes inside the caliper contracts and make frictional contact with the rotating disc in order to provide braking.

On the Basis of Brake Force Distribution

All the components of single acting hydraulic brakes and double acting hydraulic brakes whether it's a drum type single acting brake or disc type single acting brake are same as mentioned above, the only difference is type of master cylinder used which decides the brake force distribution i.e. In bikes- single wheel braking or double wheel braking, In cars- two wheel braking or all wheel braking. So let's just see that in detail.

1. Single Acting Hydraulic Brakes-

In single acting type of hydraulic brakes, simple single cylinder type of master cylinder is used which provides limited hydraulic pressure which can only be transferred in single direction i.e. In bikes- only single wheel, In cars – only single pair(front or rear) of wheels.

2. Double Acting Hydraulic Brakes-

In double acting type of hydraulic brakes, double or tandem master cylinder is used which provides higher brake force which can be transferred in double direction i.e. both wheels in bikes and all the wheels in cars.

Working of a Hydraulic Braking System

1. Drum Hydraulic Brake

When the driver apply brakes in a vehicle equipped with drum type hydraulic brakes following process take place-

- Due to the movement or actuation of brake pedal the connecting rod attached in between pedal and piston of a master cylinder moves which in turn pushes the master cylinder's piston inside the master cylinder just like a medical syringe.
- Due to this movement of the piston inside the master cylinder the compression of brake fluid inside the master cylinder takes place which in turn provides the conversion of mechanical energy into hydraulic pressure.
- This highly compressed brake fluid from the master cylinder moves inside the brake and the transfer of this hydraulic pressure from master cylinder to the brake drum takes place.
- When this high pressure brake fluid enters the wheel cylinder or drum cylinder due o its high pressure , movement in the cylinder piston takes place which in turn expands the stationary brake shoes attached to it.
- Due to the expansion of the brake shoes frictional contact between brake shoes and drum lining (the rotating drum part) is made which in turn converts the kinetic energy of the vehicle into heat energy and finally braking occurs.

Single Acting Drum Type Braking –The working of the single acting drum type hydraulic brake is exactly same as mentioned above, in this type of braking single wheel or a single pair of wheels gets the braking force.

Double Acting Drum Type Braking- In double acting hydraulic brake the high pressure brake fluid from the master cylinder is distributed in 2 directions i.e. both the wheels in bikes and all wheels in cars due to the use of tandem master cylinder (refer to the article on master cylinder)

2. Disc Hydraulic Brakes

When the driver applies brake in a vehicle equipped with disc type hydraulic brakes the process involved is same as drum hydraulic bakes up to when the high pressure brake fluid enters the brake lines but differ a bit after that

- The high pressure brake fluid from the brake lines enters the disc calliper cylinder of a disc brake system.
- This high pressure brake fluid cause's movement in the calliper cylinder's piston which in turn causes the movement of the brake pad attached to the piston inside the calliper.

- Due to this movement of brake pad the clamping of the rotating disc rotor takes place and due to this frictional contact between brake pads and the rotating disc rotor, conversion of vehicle's kinetic energy into heat energy takes place which in turn stops or de accelerate the vehicle.

Single Acting Disc Type Braking- The working of single acting disc type hydraulic braking is exactly same as mentioned above, in this type of braking single wheel or a single pair of wheels gets the braking force.

Double Acting Disc Type Braking- In double acting disc type hydraulic brake the high pressure brake fluid from the master cylinder is distributed in 2 directions i.e. both the wheels in bikes and all wheels in cars due to the use of tandem master cylinder (refer to the article on master cylinder).

Application of Hydraulic Braking

- **Drum Type Hydraulic Brakes-** They are used in some low speed four wheelers like Tata Ace.
- **Disc Type Hydraulic Brakes-** They are widely used in almost all the cars like Maruti Suzuki swift, Hyundai i20 etc and also in bikes like Bajaj pulsar 180, Ktm Duke 390 etc.
- **Single Acting Hydraulic Brakes-** Front brakes of pulsar 180 is of single acting type.
- **Dual Acting Hydraulic Brakes** – All the cars mentioned above.

8. EXPLAIN THE PNEUMATIC OR AIR BRAKES WITH NEAT SKETCH.

Air Brake System

Introduction

- A pneumatic brake or compressed air brake system is the type of brake system in which the compressed liquid fluid from the hydraulic system is replaced with the compressed air for applying pressure to the master cylinder's piston which in turn presses the brake pads in order to stop or decelerate the vehicle.
- Pneumatic air brake system is usually used in heavy vehicles like buses and trucks.

Why do we Need Air Brake System?

- As we have already discussed brake system is the need of an automobile vehicle but as we all know when it comes to the application every vehicle is not same as some vehicle are used for light utility purposes like cars and bikes and some are used for heavy purposes like buses and trucks, so there is a need of different braking systems due to the following reasons-
- As the load over light vehicle and heavy vehicle varies the brake force required to stop the heavy vehicle is far more than that of light vehicle, so the heavy vehicles should be equipped with a braking system that can provide the enough brake force that can stop or decelerate the vehicle.
- When we talk about light weight vehicles, hydraulic brakes provides more than enough brake force to stop or decelerate the vehicle due to its short dimension but when it comes to the heavy vehicles which are large in size the effectiveness of hydraulic brake system is the great concern.
- As the fluid is used to press the piston in hydraulic braking system the safety is the great concern as if there is any leak in the components of the hydraulic system the efficiency of the braking is readily reduced or even lost completely, since air is always available so the brake failure due to leakage is the less concern in air braking system.
- The components(master cylinder, brake lines etc.) size of the hydraulic brake system increases with the increase in the size of the vehicle which in turn makes it very complex to install, which is not a problem with air brake system.
- Due to the safety measures like brake failure and efficiency, Government has made it compulsory for heavy vehicles like buses and trucks to use air brake system.
- So due to these above mentioned reason on March 1872 George Westinghouse introduced air braking system for the braking system in railways due to its fail-safe feature.

Main Components

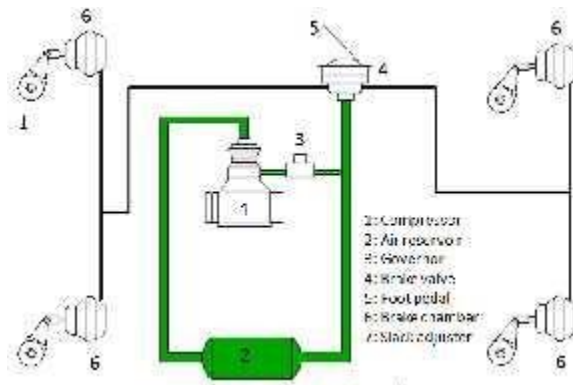

Basic Air Brake System

1. Air compressor- It is the compressor that pumps air from atmosphere to the air storage tank and is driven by the engine through belt drive.

2. Air compressor governor- It is the governing device used in air brake system that controls the compression pressure of the air that is pumped to the air storage tank through air compressor.

3. Air dryer- It is the device used to remove moisture content from the air coming from the atmosphere to prevent the lines and air storage from water condensation that can cause brake failure such as during winters due to the freezing of that condensed water.

4. Air storage (reservoir)- It is the tank that is used to store the compressed air sent by the compressor, this storage always has enough amount of compressed air so that the brakes can be applied several time and also prevents the brake failure when the air compressor shows malfunctioning.

5. Brake pedal- It is the mechanism that is operated by the driver and is used to actuate the brakes in order to stop or decelerate the vehicle. Brakes when pressed pushed the compressed air which in turn applies brakes to the moving tyre.

6. Dirt collector- It is the device that is placed inside a brake pipe line at place where a branch is separated and taken off to the triple valve which removes dirt from the air before sending it to the triple valve

7. Brake cylinder or Brake chamber- It is the device that consists of a cylinder and piston over which the compressed air pressure is applied in order to push brake pads which in turn makes frictional contact with the disc or drum in order to stop or decelerate the vehicle.

8. Brake valve or Triple valve- The actuation and release of brake requires continuous release and building of pressure inside the brake lines and brake cylinder according to the motion of the brake pedal this is done by the triple valve used in air brake system.

9. Brake drums – Brake drum is the component through which the brake force due to frictional contact between brake pads and drum lining is transferred to the wheel in order to stop or decelerate the vehicle, Outer surface of the brake drum consisting of drum lining rotates with the wheel and the inner part consisting of brake shoes stays in its state of rest when the brake pedal is not pressed.

Note – Usually brake drums are used in air brake system but with suitable arrangement disc brake can also be used in air brake system.

Working of Air Brake System

- When the driver of a vehicle presses the brake pedal in order to stop or decelerate the vehicle the following processes takes place-
- When the driver starts the engine the brake compressor starts as it is driven by the engine which in turn starts compressing the atmospheric air and through the compressor governor this compressed air with optimum pressure is sent to the compressed air reservoir which always has some amount of air stored from the previous cycle.

- When the driver presses the brake pedal the outlet valve of the triple valve closes and inlet valve opens up which in turn gives passage to the compressed air from the reservoir to pass through the brake lines of the system.
- This compressed air flowing through the brake lines is then transferred to the brake cylinder which has piston inside it.

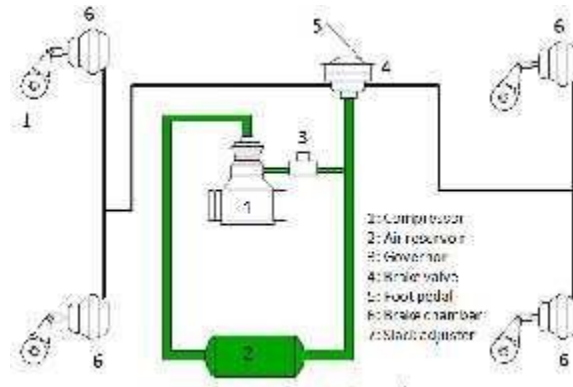

Basic Air Brake System (when brakes are not applied)

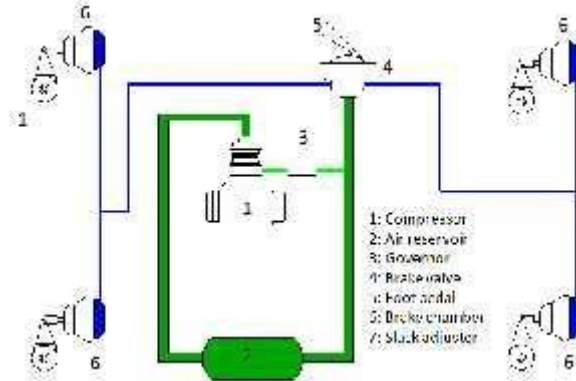

Basic Air Brake System (when brakes are applied)

- When the compressed air applies pressure over the piston inside the brake chamber, piston moves away from its original position which converts this pneumatic energy into the mechanical energy.
- On the wheel end of the brake cylinder, brake drums are placed inside which there is a housing of the mechanical actuator like springs or slacks having brake pads at its outer end.
- Due to the movement of piston because of the pressure applied by the compressed air, The mechanical actuator inside the brake drum expands which in turn pushes the brake pads in outward direction in order to make frictional contact with the rotating drum lines.
- With this frictional contact between brake pads and rotating drum lines brakes are applied to the wheels in order to stop or decelerate the vehicle.

Application

Due to its property of preventing brake failure air brakes systems are widely used in various vehicles but in heavy vehicles like trucks and buses due to the government vehicle regulations air brake system is mandatory.

- It is used in railways
- All the trucks and busses on the road today use air brake systems, few from them are.

1. Volvo 9400PX buses.
2. Bharat Benz 3123R truck.
- 3.

9. EXPLAIN THE VACUUM BRAKE SYSTEM WITH NEAT SKETCH.

VACUUM BRAKE SYSTEM

Introduction

- The vacuum brake was, for many years, used in place of the air brake as the standard, fail-safe, train brake on railways in the UK and countries whose railway systems were based on UK practice. Here is a simplified description of the vacuum system.

Basics

- A moving train contains energy, known as kinetic energy, which needs to be removed from the train in order to cause it to stop. The simplest way of doing this is to convert the energy into heat. The conversion is usually done by applying a contact material to the rotating wheels or to discs attached to the axles. The material creates friction and converts the kinetic energy into heat. The wheels slow down and eventually the train stops. The material used for braking is normally in the form of a block or pad.
- The vast majority of the world's trains are equipped with braking systems which use compressed air as the force used to push blocks on to wheels or pads on to discs. These systems are known as "air brakes" or "pneumatic brakes". The compressed air is transmitted along the train through a "brake pipe". Changing the level of air pressure in the pipe causes a change in the state of the brake on each vehicle. It can apply the brake, release it or hold it "on" after a partial application. The system is in widespread use throughout the world.
- An alternative to the air brake, known as the vacuum brake, was introduced around the early 1870s, the same time as the air brake. Like the air brake, the vacuum brake system is controlled through a brake pipe connecting a brake valve in the driver's cab with braking equipment on every vehicle. The operation of the brake equipment on each vehicle depends on the condition of a vacuum created in the pipe by an ejector or exhauster. The ejector, using steam on a steam locomotive, or an exhauster, using electric power on other types of train, removes atmospheric pressure from the brake pipe to create the vacuum. With a full vacuum, the brake is released. With no vacuum, i.e. normal atmospheric pressure in the brake pipe, the brake is fully applied.
- The pressure in the atmosphere is defined as 1 bar or about 14.5 lbs. per square inch. Reducing atmospheric pressure to 0 lbs. per square inch, creates a near perfect vacuum which is measured as 30 inches of mercury, written as 30 Hg. Each 2 inches of vacuum therefore represents about 1 lb. per square inch of atmospheric pressure.
- In the UK, vacuum brakes operated with the brake pipe at 21 Hg, except on the Great Western Railway which operated at 25 Hg.
- The vacuum in the brake pipe is created and maintained by a motor-driven exhauster. The exhauster has two speeds, high speed and low speed. The high speed is switched in to create a vacuum and thus release the brakes. The slow speed is used to keep the vacuum at the required level to maintain brake release. It maintains the vacuum against small leaks in the brake pipe. The vacuum in the brake pipe is prevented from exceeding its nominated level (normally 21 Hg) by a relief valve, which opens at the setting and lets air into the brake pipe to prevent further increase.
- *Principal Parts of the Vacuum Brake System. This diagram shows the principal parts of the vacuum brake system as applied to an electric or diesel train. The systems used on steam locomotives were somewhat different. Diagram: Author*

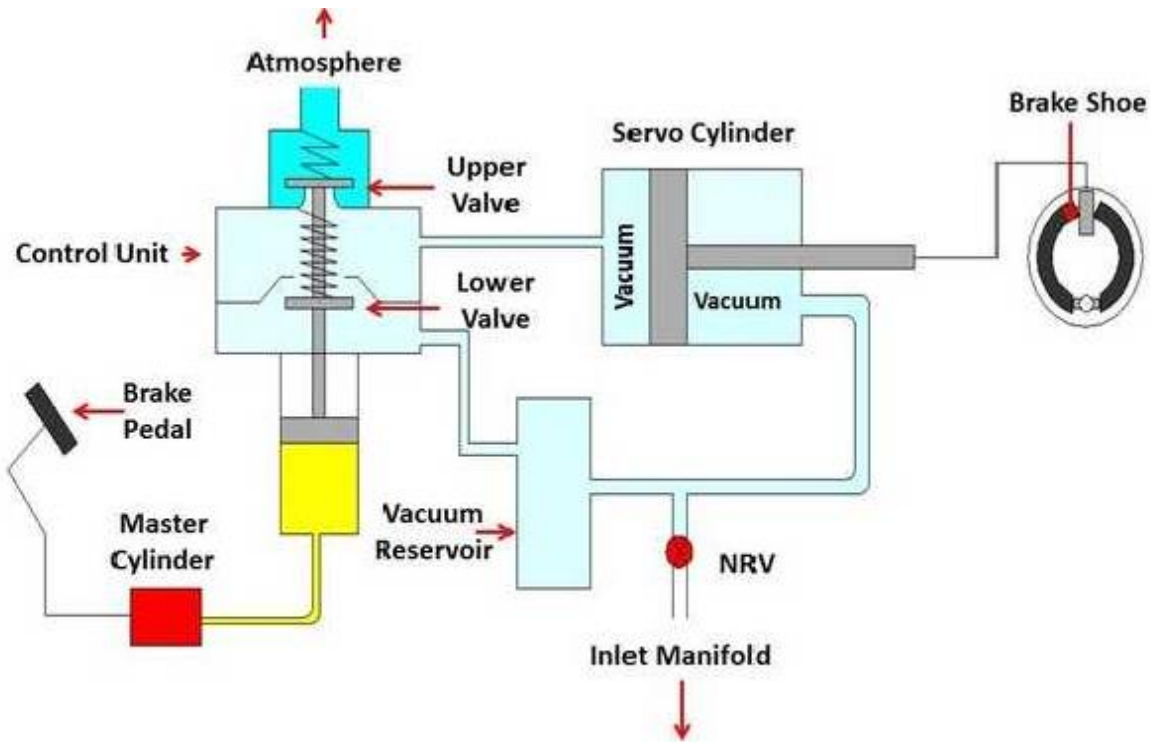

Vacuum Booster/Brake When Brake is Released

Vacuum air brake system

Driver's Brake Valve

- The means by which the driver controls the brake. The brake valve will have (at least) the following positions: "Release", "Running", "Lap" and "Brake On". There may also be a "Neutral" or "Shut Down" position, which locks the valve out of use. The "Release" position connects the exhauster to the brake pipe and switches the exhauster to full speed. This raises the vacuum in the brake pipe as quickly as possible to get a release.
- In the "Running" position, the exhauster keeps running but at its slow speed. This ensures that the vacuum is maintained against any small leaks or losses in the brake pipe, connections and hoses.
- "Lap" is used to shut off the connection between the exhauster and the brake pipe to close off the connection to atmosphere after a brake application has been made. It can be used to provide a partial release as well as a partial application, something not possible with the original forms of air brake.
- "Brake On" closes off the connection to the exhauster and opens the brake pipe to atmosphere. The vacuum is reduced as air rushes in.



A driver's brake valve for a DMU. Photo: Traction ads.

- Some brake valves were fitted with an "Emergency" position. Its operation was the same as the "Brake On" position, except that the opening to atmosphere was larger to give a quicker application.

Exhauster

- A two-speed rotary machine fitted to a train to evacuate the atmospheric pressure from the brake pipe, reservoirs and brake cylinders to effect a brake release. It is usually controlled from the driver's brake valve, being switched in at full speed to get a brake release or at slow speed to maintain the vacuum at its release level whilst the train is running. Exhausters are normally driven off an electric motor but they can be run directly from a diesel engine. See also Ejector.

Brake Pipe

- The vacuum-carrying pipe running the length of the train, which transmits the variations in pressure required to control the brake. It is connected between vehicles by flexible hoses, which can be uncoupled to allow vehicles to be separated. The use of the vacuum system makes the brake "fail safe", i.e. the loss of vacuum in the brake pipe will cause the brake to apply.

Dummy Coupling

- At the ends of each vehicle, a dummy coupling point is provided to allow the ends of the brake pipe hoses to be sealed when the vehicle is uncoupled. The sealed dummy couplings prevent the vacuum being lost from the brake pipe.

Coupled Hoses

- The brake pipe is carried between adjacent vehicles through flexible hoses. The hoses can be sealed at the outer ends of the train by connecting them to dummy couplings.

Brake Cylinder

- Each vehicle has at least one brake cylinder. Sometimes two or more are provided. The movement of the piston contained inside the cylinder operates the brakes through links called "rigging". The rigging applies the blocks to the wheels. I do not know of a vacuum brake system which uses disc brakes. The piston inside the brake cylinder moves in accordance with the change in vacuum pressure in the brake pipe. Loss of vacuum applies the brakes, restoration of the vacuum releases the brakes.

Vacuum Reservoir

- The operation of the vacuum brake relies on the difference in pressure between one side of the brake cylinder piston and the other. In order to ensure there is always a source of vacuum available to operate the brake, a vacuum reservoir is provided on, or connected to the upper side of the piston. In the simplest version of the brake, shown above, the brake cylinder is integral with the vacuum reservoir. Some versions of the brake have a separate reservoir and a piped connection to the upper side of the piston.

Brake Block

- This is the friction material which is pressed against the surface of the wheel tread by the upward movement of the brake cylinder piston. Often made of cast iron or some composition material, brake blocks are the main source of wear in the brake system and require regular inspection to see that they are changed when required.

Brake Rigging

- This is the system by which the movement of the brake cylinder piston transmits pressure to the brake blocks on each wheel. Rigging can often be complex, especially under a passenger car with two blocks to each wheel, making a total of sixteen. Rigging requires careful adjustment to ensure all the blocks operated from one cylinder provide an even rate of application to each wheel. If you change one block, you have to check and adjust all the blocks on that axle.

Ball Valve

- The ball valve is needed to ensure that the vacuum in the vacuum reservoir is maintained at the required level, i.e. the same as the brake pipe, during brake release but that the connection to the brake pipe is closed during a brake application. It is necessary to close the connection as soon as the brake pipe vacuum is

reduced so that a difference in pressure is created between the upper and lower sides of the brake cylinder piston. See the next paragraph - Operation on Each Vehicle.

Operation on Each Vehicle

Brake Release

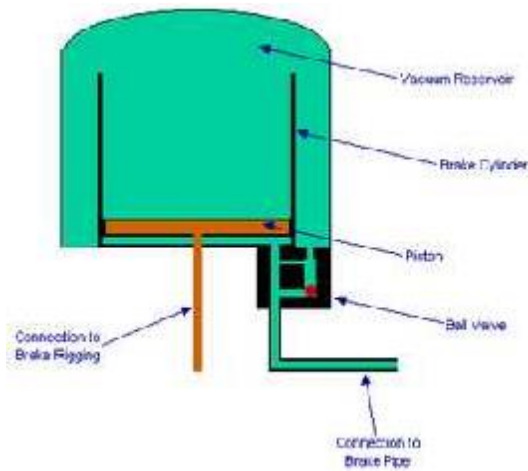

- This diagram shows the condition of the brake cylinder, ball valve and vacuum reservoir in the release position. The piston is at the bottom of the brake cylinder. Note how the brake cylinder is open at the top so that it is in direct connection with the vacuum reservoir. Diagram: Author.
- A vacuum has been created in the brake pipe, the vacuum reservoir and underneath the piston in the brake cylinder. The removal of atmospheric pressure from the system has caused the ball valve to open the connection between the vacuum reservoir and the brake pipe. The fall of the piston to the bottom of the brake cylinder causes the brake blocks to be released from the wheels.

Brake Application

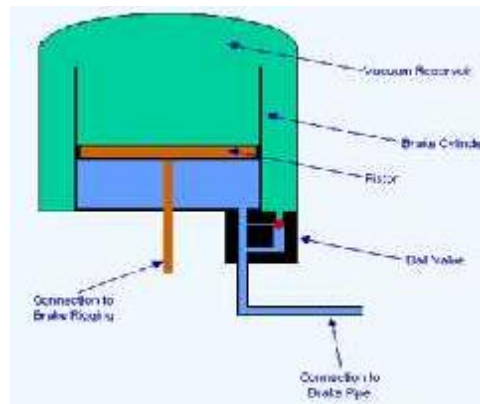

- This diagram shows the condition of the brake cylinder, ball valve and vacuum reservoir in the application position. The vacuum has been reduced by the admission of atmospheric pressure into the brake pipe. This has forced the piston upwards in the brake cylinder. By way of the connection to the brake rigging, the upward movement of the piston has caused the brake blocks to be applied to the wheels. Diagram: Author.
- The movement of the piston in the brake cylinder relies on the fact that there is a pressure difference between the underside of the piston and the upper side. During the brake application, the vacuum in the brake pipe is reduced by admitting air from the atmosphere.
- As the air enters the ball valve, it forces the ball (in red in the diagram above) upwards to close the connection to the vacuum reservoir. This ensures that the vacuum in the reservoir will not be reduced. At the same time, the air entering the underside of the brake cylinder creates an imbalance in the pressure compared with the pressure above the piston. This forces the piston upwards to apply the brakes.

10. EXPLAIN THE ANTI-LOCK BRAKING SYSTEM WITH SUITABLE SKETCH.

Anti-lock Braking System (ABS)

What is Anti-lock Braking System?

- **Anti-lock Braking System** also known as anti-skid braking system (ABS) is an automobile safety system which prevents the locking of wheels during braking and avoid uncontrolled skidding. The modern abs system allows steering during braking which gives more control over the vehicle in case of sudden braking.
- The main advantages of using ABS system in vehicle is that it provides better control over the vehicle and decreases stopping distance on dry and slippery surfaces. Since in ABS installed vehicle the chance of skidding is very less and hence it provides a better steering control during braking.
- Without ABS system, even a professional driver can fail to prevent the skidding of the vehicle on dry and slippery surfaces during sudden braking. But with ABS system, a normal person can easily prevent the skidding of the vehicle and get better steering control during braking.

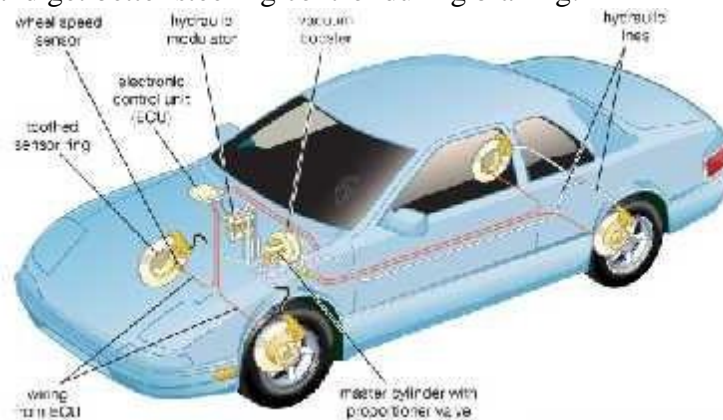

ABS

Principle of Working

- It works on the principle of threshold braking and cadence braking. Cadence braking and threshold braking is a technique in which a driver applies the brakes and releases it before locking up the wheel and then applies the brakes and releases it again before locking.
- This process of applying and releasing the brakes on the wheel is done in pulse form to prevent it from locking and stop skidding of the vehicle.
- The driver practices this technique to achieve better control over the vehicle during instant braking and stop skidding of the vehicle.
- The ABS system automatically does this cadence braking to prevent locking of wheel and skidding of vehicle when brakes are applied.

Why Anti-lock Braking System (ABS) is essential in vehicles?

- To understand this in a better way let's take an incident. When you are driving your car on a highway and suddenly an obstacle comes in front of you and you apply brake with full power. This will lock wheels of your car and your car will start skidding on the road and also during skidding you lost your steering control and unable to move the car in desired direction in which you want. Finally you hit that obstacle and meet an accident.
- Let's us take another situation, now you are driving a car which is equipped with anti-lock braking system. When you encounter with an obstacle on the road and suddenly apply the brakes.
- But this time the ABS system of your car prevent the locking of the wheel and avoid skidding. At this time you can control your steering and can stop your car hitting from the obstacle. This is how the abs system prevents the skidding of the vehicle and provides greater control over it and prevents accidents.

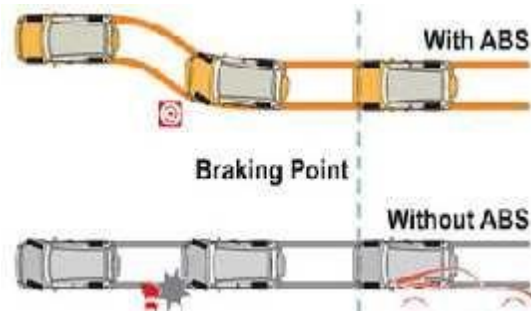

Main Components of ABS System

It has four main components

1. speed sensors
2. Valves
3. Pump
4. Controller

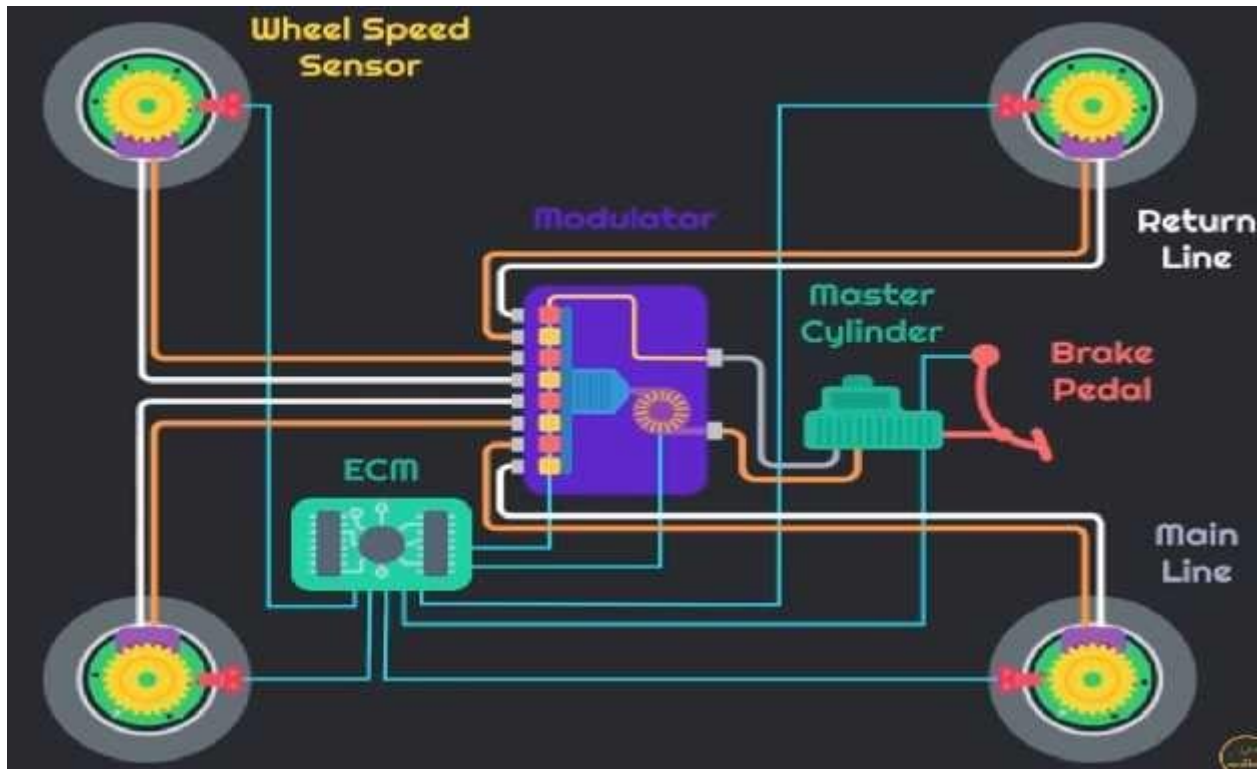

1. Speed Sensors

- It is used to calculate the acceleration and deceleration of the wheel. It consists of a toothed wheel and an electromagnetic coil or a magnet and a Hall Effect sensor to generate signal.
- When the wheel or differentials of the vehicle rotates, it induces magnetic field around the sensor. The fluctuation in this magnetic field generates voltage in the sensor. This voltage generated sends signals to the controller. With the help of the voltage the controller reads the acceleration and deceleration of the wheel.

2. Valves

Each brake line which is controlled by the ABS has a valve. In some of the systems, the valve works on three positions.

1. **In position one**, the valve remains open; and pressure from the master cylinder passed through it to the brake.
2. **In position two**, the valve blocks the line and separates the brake from the master cylinder. And this prevents the further rise of the pressure to the brakes. Valve operates in second position when the driver applies the brake harder.
3. **In position three**, some of the pressure from the brake is released by the valve.

The clogging of the valve is the major problem in ABS. When the valve is clogged, it becomes difficult for the valve to open, close or change position. When the valve is in inoperable condition, it prevents the system from modulating the valves and controlling pressure to the brakes.

3. Pump

- Pump is used to restore the pressure to the hydraulic brakes after the valve releases the pressure. When the controller detects wheel slip, it sends signals to release the valve. After the valve releases the pressure supplied from the driver, it restore a desired amount of pressure to the braking system. The controller modulates (adjust) the status of the pump so as to provide desired amount of pressure and reduce slipping of the wheel.

4. Controller

- The controller used in the ABS system is of ECU type. Its main function is to receives information from each individual wheel speed sensors and if a wheel loses its traction with the ground, a signal is sent to the controller, the controller than limit the brake force (EBD) and activate the ABS modulator. The activated ABS modulator actuates the braking valves on and off and varies the pressure to the brakes.

Working of Anti-lock Braking System (ABS)

- The controller (ECU-Electronic Control Unit) reads the signal from each of the speed sensors of the wheel.
- As the brakes are suddenly applied by the driver, this makes the wheel to decelerate at faster rate and may cause the wheel to Lock.
- As the ECU reads the signal which indicates the rapid decrease in the speed of the wheel, it sends signal to the valve which makes the valve close and the pressure to the brake pad reduces and prevents the wheel from locking.
- The wheel again starts to accelerate, again the signal sends to the controller, this time it opens the valve, increasing the pressure to the brake pad and brakes are applied, this again reduces the speed of the wheel and tries to make it stop.
- This process of applying brakes and releasing it happens 15 times in a second when a driver suddenly applies the brake harder. Due to this the locking of the wheel is prevented and the skidding of the vehicle eliminated.
- During braking with ABS system, the driver can steer the vehicle and reduces the risk of vehicle collision.
- When the ABS in operation, it can be felt by the driver through pulsation in the brake pedal; this happens because of the rapid opening and closing of the valves. The pulsing action of the pedal tells the driver that ABS system is in operation. Any fault in the ABS system is indicated on the instrument panel of the vehicle and it will work when the fault is completely removed.

Advantages

1. It prevents the locking of the wheel and thus eliminates the chance of skidding.
2. The skidding of the vehicle is completely removed, which results in excellent control during braking?
3. A better steering control is obtained with the ABS system.
4. It reduces the chance of collision by 30 %.

Disadvantages

A vehicle equipped with ABS (Anti-lock Braking System) is costlier as compared with a vehicle without ABS.

11. WHAT IS EBD (ELECTRONIC BRAKE FORCE DISTRIBUTION) AND HOW DOES IT WORK?

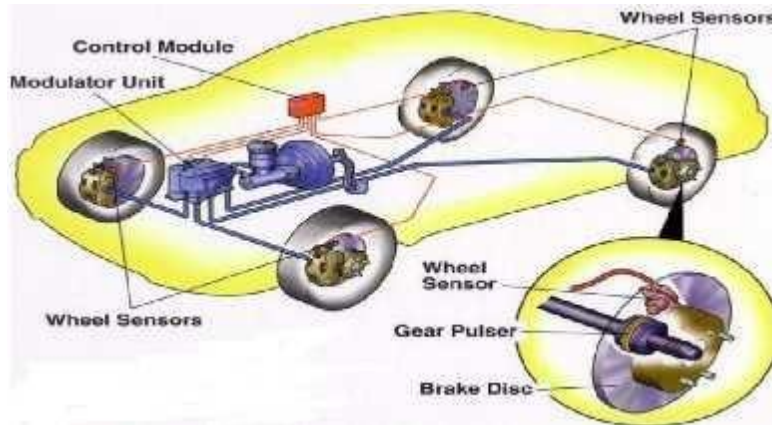

- Most of the cars today come fitted with ABS or Anti-lock Braking system. Coupled along with ABS, there is another electronic marvel called the **EBD or electronic brake force distribution**. Simply put, EBD is a system wherein the amount of braking force on each wheel of the car can be varied taking factors such as load bearing on each wheel, condition of the road, speed of the vehicle and so on.

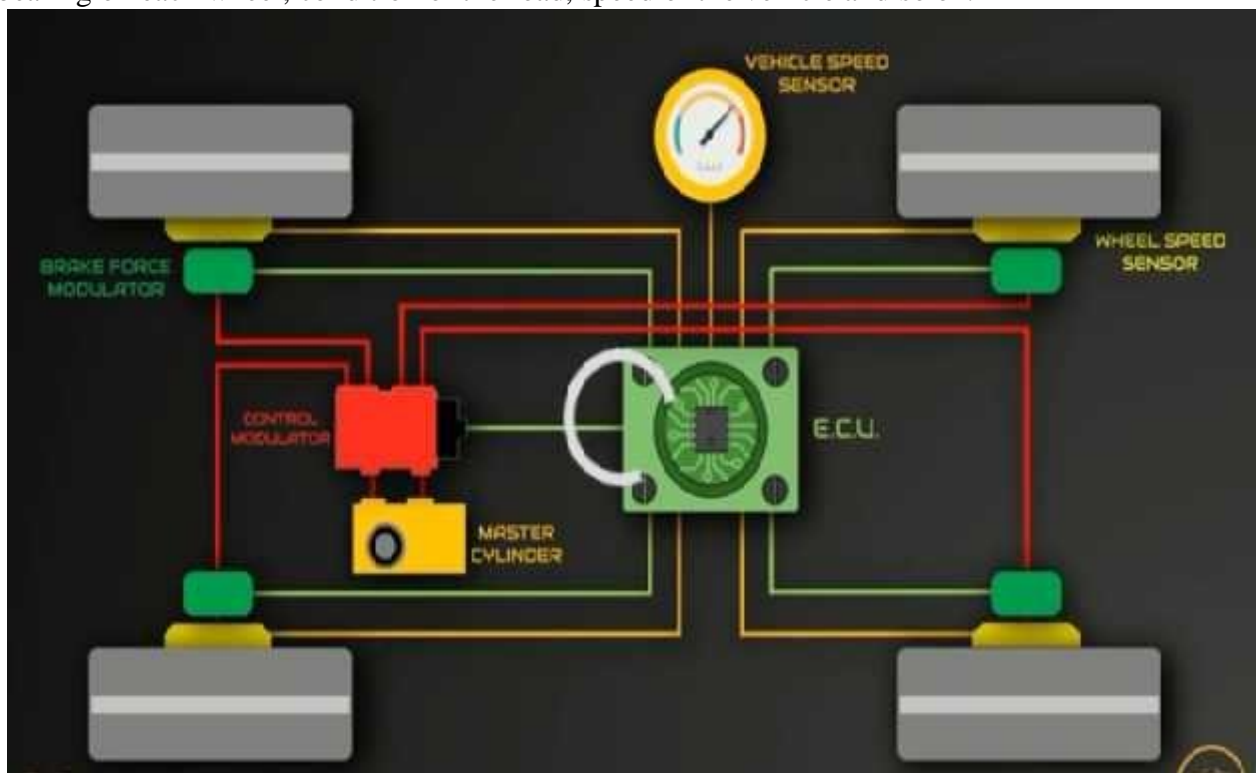

How does it work?

The hardware of EBD comprises the following components which are:

1. Wheel Speed sensors
2. Load sensor
3. Brake force modulators / Valves
4. Electronic Control Unit ([ECU](#))

- The simple idea behind an EBD system is that it need not be necessary to apply the same amount of braking force on each wheel so as to reduce the speed of the car or bring it to a complete stop. An EBD system

makes use of four components which make it tick. The speed sensors, Load sensor, brake force modulators and electronic control unit (ECU).

1. Speed Sensor: The speed sensor not only calculates the speed of the car, but the speed of the engine also (RPM). One of the scenarios can be that the speed of the wheel might not be the same as the speed of the car. Such a situation can lead to the wheel(s) skidding. The speed sensors calculate the slip ratio and relay it to ECU.

2. Load sensor: This sensor is used to find out the weight in each wheels and distribute the equal brake pressure to the system

3. Electronic Control Unit: It is a small chip which collects the data from the speed sensors in each wheel and uses the data to calculate the slip ratio (difference between the speed of the car and the rotation of the tyre). Once the slip ratio is determined, it makes use of the brake force modulators to keep the slip ratio within limits.

4. Brake Force Modulators: It is the job of these modulators to pump brake fluid into the brake lines and activate the brake cylinders. The brake force applied on each wheel can be modulated.

- In this mechanism, each wheel has a separate sensor mounted on it for precise calculation of their speed. Additionally, there is a load sensor which measures the weight distribution between the front and the rear wheels of the vehicle.
- In the event of braking, based on the feedback received from the load sensor and the wheel speed sensors, the ECU calculates the braking force for each wheel separately.
- It then applies only that much force for that particular wheel. In addition, it can even reduce the excess brake force applied to other wheels. The actual application of hydraulic pressure i.e. brake force is carried out by the Brake Force modulators or the valves.
- There is a difference between the Anti-lock Braking System or ABS and the EBD. In fact, the Electronic Brake force Distribution can actually sense the weight supported by each wheel at every moment. Hence, it can calculate the required braking force which is not the case with the ABS. Nowadays, many car manufacturers like Toyota, Honda, and Mazda offer EBD as standard on their models.

12. EXPLAIN THE TRACTION CONTROL WITH SUITABLE SKETCH

Traction Control

Basic Description

- A traction control system prevents wheel spin from occurring due to a loss of traction during acceleration. This usually happens on a slippery surface, such as snow or wet road, where the wheels are not able to generate enough traction to move the vehicle.
- Antilock braking systems ([ABS](#)) also prevent a vehicle's wheels from slipping due to a loss of traction. The major difference between an ABS and traction control systems is that ABS stops the wheel from losing traction while braking, while traction control stops the wheel from spinning when the vehicle is accelerating.
- Traction control systems are often referred to by other names (e.g. anti-slip regulation or stability control); however traction control is not the same as [electronic stability control](#) or [active yaw control](#).
- Traction control systems use wheel speed sensors to determine the rate at which the drive wheels are rotating. They detect if there is any slip occurring between the tire and the road. If slip is detected, the system slows the wheel by applying the brake or reducing the torque to that wheel until it is able to generate the required amount of friction for the vehicle to move.
- In vehicles with a standard differential, applying the brake to a slipping wheel, increases the amount of torque delivered to the opposite wheel, which may have better traction. If both the driven wheels are losing traction, traction control systems usually slow both the slipping wheels equally until they regain traction.

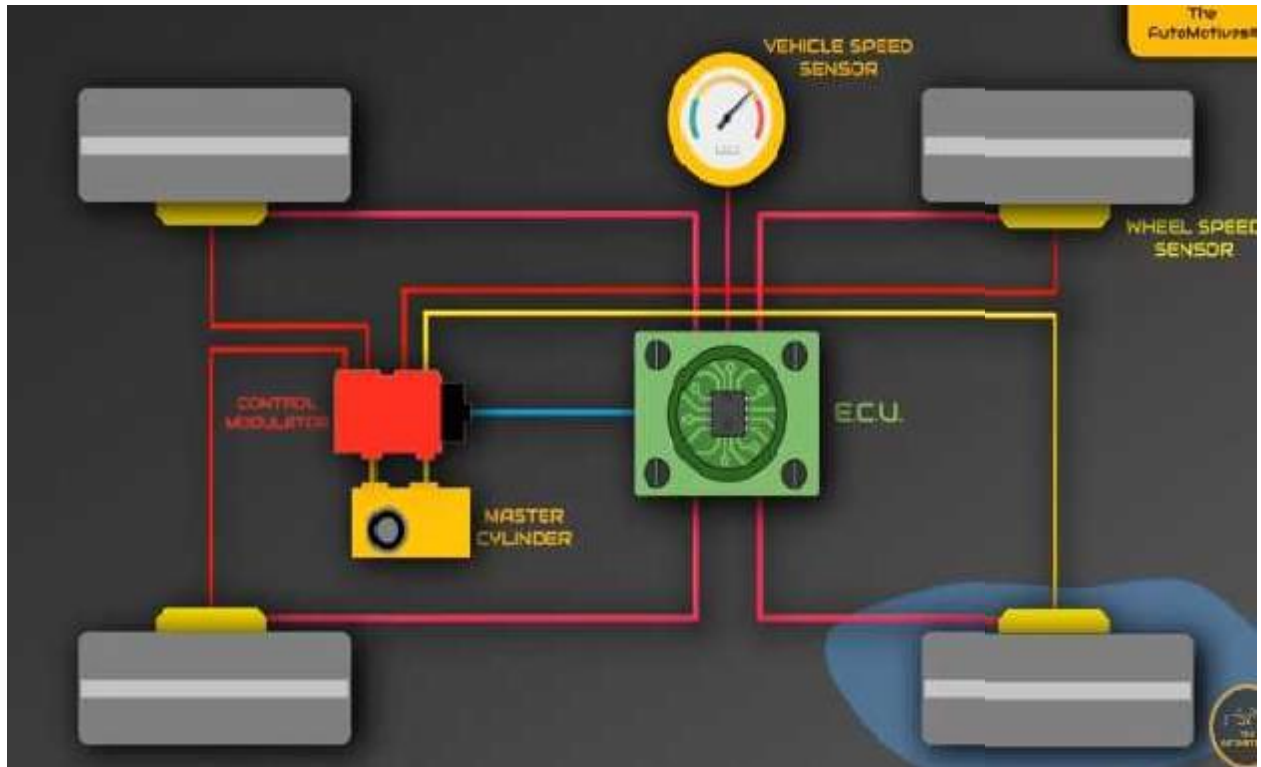
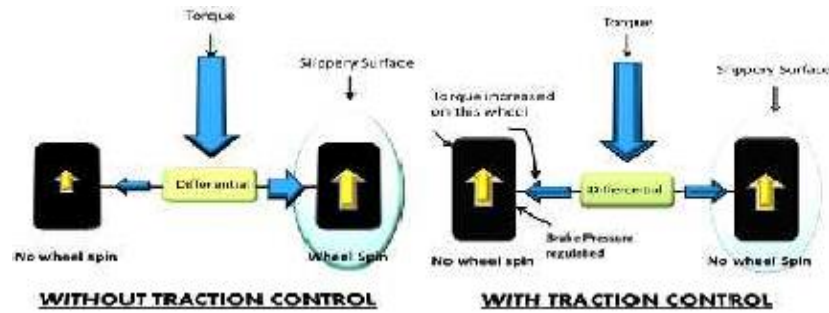

- Some performance vehicles provide the option to switch off the traction control system.
- **Traction Control System** is a well-known car safety feature that has become integral in ensuring the safety of the driver and passengers. Car brands are working tirelessly to improve the standard of car safety technologies offered in their new and upcoming cars. With the advancement in modern day technologies, car brands have been successful in developing **advanced technological features** that help to improve the safety of the occupants of a car and increase its reliability in challenging driving conditions.
- Driving on wet roads and slippery conditions can be really troublesome even for seasoned drivers because the handling of the vehicle becomes a lot more difficult in such conditions. *The vehicle can spin or slide off the road when the road is slippery, which can be dangerous for everyone sitting inside the car and other commuters on the road.* A vehicle that slips or spins out of control can cause extremely dangerous situations, especially on roads with heavy traffic.
- **Traction Control System** or simply Traction Control is a safety feature that ensures improved stability of the vehicle on wet roads and gives more control to the driver to stop the vehicle from slipping. Tyres without the Traction Control System become susceptible to slipping on wet roads and don't maintain enough grip on the road, which endangers the safety of passengers.
- Here is everything one must know about this safety feature, how it can help a driver and when it is most effective.

What is Traction Control System?

- Traction Control is an **active safety feature** which ensures that the vehicle makes use of the maximum available traction on the road when driving on low-friction surfaces. If a vehicle with no traction system tries to accelerate on a **slippery surface such as loose gravel, snow or ice**, the tyres become vulnerable to sliding and slipping.
- **Without the Traction Control System**, the tyres spin very quickly on a wet road because of reduced grip and stability. The driver can completely lose control of the vehicle in such circumstances and that can result in a dangerous road accident. However, this can be avoided with the Traction Control System as this cutting-edge safety technology improves a vehicle's stability by adjusting the acceleration of the vehicle according to the road condition.
- *Traction Control System will activate automatically when it senses that the wheels might slip and helps the driver to make use of the maximum traction available on the road surface.* This system only utilizes the available traction on a road to optimize acceleration of the vehicle and does not have the ability to create any traction of its own.
- Traction Control is often a secondary function of the [Electronic Stability Control](#), however, it is a complete safety technology that can perform its function independently as well.

When is Traction Control Most Effective?

- This system is most effective when the vehicle is trying to accelerate on a slippery and uneven road. *The effectiveness of the Traction Control System can increase even more if the driver remains attentive and drives slowly and carefully in slippery conditions.* A proactive and safe driving approach coupled with Traction Control System can **help in maneuvering a vehicle around sharp turns on a wet road** with relative ease.
- However, there are some limitations of the Traction Control System. **This system does support the snow tyres and doesn't improve the stability of the vehicle when driving in mud.** Drivers are, in fact, advised to turn off Traction Control System if they are stuck in mud because in such driving conditions, this system doesn't get any available traction from the road.

Usefulness of Traction Control System

- Traction Control System can be very useful in the driving conditions such as poorly maintained roads, loose gravel, uneven roads and wet roads. This safety feature can be useful when:
 - ❖ **Uphill drives** – Trying to accelerate while going uphill on a path that is rough and uneven.
 - ❖ **Wet road conditions** – Driving on a wet road that can cause the vehicle to slow down as the wheels will not get enough traction to speed up.
 - ❖ **Accelerating from standstill position** – Trying to accelerate at a green traffic light on a wet and slippery road with traffic approaching from behind.
- Many **advanced Traction Control Systems reduce the power of the engine** to manage the acceleration of the vehicle better on wet roads. It saves the vehicle from slipping and hence has its importance in avoiding a fatal crash. Drivers feel more comfortable when they have the Traction Control System in their vehicles because this system automatically adjusts the acceleration according to the condition of the road.

PRINCIPAL OF ENGINE EMISSIONS AND EMISSION STANDARDS.

SI Engines	CO, HC and NO _x
CI Engines	CO, HC, NO _x and PM

- CO = Carbon monoxide, HC = Unburned hydrocarbons, NO_x = Nitrogen oxides mainly mixture of NO and NO₂, PM = Particulate matter
- Other engine emissions include aldehydes such as formaldehyde and acetaldehyde primarily from the alcoholfuelled engines, benzene and polyaromatic hydrocarbons (PAH).

Sources of Engine/Vehicle Emissions

- Figure shows the sources of emissions from a gasoline fuelled SI engine viz., exhaust, crankcase blow by and fuel evaporation from fuel tank and fuel system



Emission sources in a gasoline fuelled car.



Emission sources in a Diesel powered bus.

Emissions and Pollutants

Engine emissions undergo chemical reactions in atmosphere known largely as ‘photochemical’ reactions and give rise to other chemical species which are hazardous to health and environment. Linkage of engine emissions and air pollutants is shown in Fig.

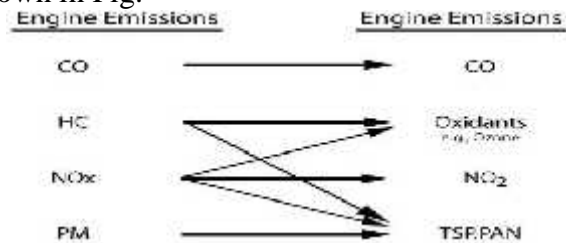

TSP = Total suspended particulate matter in air
 PAN = Peroxy- acetyl nitrate

Air pollutants resulting from engine emission

The effect of pollutants on human health depends on pollutant concentration in the ambient air and the duration to which the human beings are exposed. Adverse health effects of different pollutants on human health are given in Table for short term and long term exposures. Carbon monoxide on inhalation is known to combine with haemoglobin at a rate 200 to 240 times faster than oxygen thus reducing oxygen supply to body tissues and results in CO intoxication. Nitrogen oxides get dissolved in mucous forming nitrous and nitric acids causing irritation of nose throat and respiratory tract. Long term exposure causes nitrogen oxides to combine with haemoglobin and destruction of red blood cells. Long term exposure resulting in more than 10% of haemoglobin to combine with nitrogen oxides causes bluish colouration of skin, lips fingers etc

Pollutants	Short term health effects	Long-term health effects
Carbon monoxide	Headache, shortness of breath, dizziness, impaired judgment, lack of motor coordination	Effects on brain and central nervous system, nausea, vomiting, cardiac and pulmonary functional changes, loss of consciousness and death
Nitrogen dioxide	Soreness, coughing, chest discomfort, eye irritation	Development of cyanosis especially at lips, fingers and toes, adverse changes in cell structure of lung wall
Oxidants	Difficulty in breathing, chest tightness, eye irritation	Impaired lung function, increased susceptibility to respiratory function
Ozone	Similar to those of NO ₂ but at a lower concentration	Development of emphysema, pulmonary edema
Sulfates	Increased asthma attacks	Reduced lung function when oxidants are present
TSP/Respirable suspended particulate	Increased susceptibility to other pollutants	Many constituents especially poly-organic matter are toxic and carcinogenic, contribute to silicosis, brown lung

Historical Overview: Engine and Vehicle Emission Control

Beginning with the identification during early 1950s that mainly the unburned hydrocarbons and nitrogen oxides emitted by vehicles are responsible for formation of photochemical smog in Los-Angeles region in the US, the initiatives and milestones in pursuit of vehicle/ engine emission control are given in Table

Year	Event and Milestone
1952	Prof A. J. Haagen- Smit of Univ. of California demonstrated that the photochemical reactions between unburned hydrocarbons (HC) and nitrogen oxides (NO _x) are responsible for smog (brown haze) observed in Los-Angeles basin
1965	The first vehicle exhaust emissions standards were set in California, USA
1968	The exhaust emission standards set for the first time throughout the USA
1970	Vehicle emission standards set in European countries
1974	Exhaust catalytic converters for oxidation of carbon monoxide (CO) and HC were needed in the US for meeting emission targets. Phasing-out of tetra ethyl lead (TEL), the antiknock additive from gasoline begins to ensure acceptable life of the catalytic converters
1981	Three-way catalytic converters and closed-loop feedback air-fuel ratio control for simultaneous conversion of CO, HC and NO _x introduced on production cars
1992	Euro 1 emission standards needing catalytic emission control on gasoline vehicles implemented in Europe
1994	Catalytic emission control for engines under lean mixture operation introduced
1994	US Tier -1 standards needing reduction in CO by nearly 96%, HC by 97.5% and NO _x by 90%
2000-2005	Widespread use of diesel particulate filters and lean de-NO _x catalyst systems on heavy duty vehicles
2004	US Tier -2 standards needing reduction in CO by nearly 98 %, HC by 99% and NO _x by 95%

EMISSION STANDARDS

- The vehicle emission standards were implemented for the first time in 1965 when control of crankcase hydrocarbon emissions from gasoline passenger cars was required as per the law. Use of positive crankcase ventilation (PCV) system on the gasoline passenger cars became necessary to prevent emission of hydrocarbon rich crankcase blow by gases into atmosphere.
- At the same time, the exhaust gas emission standards for new cars were also established in the state of California and in 1968, US enacted legislation to implement nationwide vehicle emission regulations. In Europe, vehicle emission standards were implemented beginning from the year 1970.
- Over the years, the emission standards have become more and more stringent and have driven the development of advanced engine designs and emission control technology. Now, nearly all the countries all over the world have enforced vehicle emission regulations of varying severity following largely either the US or the European regulations. The emission limits that are in force in the US and Europe and the trends thereof over the years are discussed below.

Light Duty Vehicles

US Standards

- The US emission standards for passenger cars are given in Table 4.1 since the limits were set for the first time under the Clean Air Act of 1968. The standards set for 1975 were rather stringent such that the oxidation catalytic converters were required on most cars. Amendments to Clean Air Act in 1977 resulted in the standards that required in 1980/1981 reduction of 90% in HC and CO, and 75% in NO_x. The 1980-81 standards resulted in widespread use of 3-way catalyst technology.
- During 1990s, the 1977 amendments were found inadequate as 9 US cities had higher ozone levels and 41 cities higher CO levels than the air quality standards. The 1990 Clean Air Act Amendments (CAAA) followed resulting in further tightening of the emission standards besides other measures like introduction of better quality fuels such as the reformulated gasoline. The new emission regulations known as Tier 1 were implemented from 1994 and Tier 2 standards from 2004 through to 2009. It is seen that the current production vehicles emit less than 1% of emissions of pre-control era vehicles.
- In the mean time California introduced a new set of emission regulations (Table 4.2) and called the vehicles meeting these regulations by the name of different grades of low emission vehicles (LEV) such as TLEV (Transitional), LEV, ULEV (Ultra), SULEV (Super Ultra) and PZEV (Partial zero emission vehicles).

US Federal Emission Standards for Passenger Cars, g/mile

Year	NMOG/ NMHC	CO	NO _x	PM (1)	HCHO(2)	Evap. g/test
US Federal						
Pre-control (1966)	15 (3)	90	6.2			8.0
1975	1.5 (3)	15	3.1			2.0 (4)
1981	0.41 (3)	3.4	1.0			2.0 (5)
Tier1 ⁽⁶⁾ , 1994						(7)
Gasoline	0.25(0.31)	3.4 (4.2)	0.4 (0.6)			
Diesel	0.25(0.31)	3.4 (4.2)	1.0 (1.25)	1.08 (0.10)		
Tier2 ⁽⁸⁾ , 2004 - 2009	0.125	1.7	0.2	0.02	0.018	(7)

NMHC/NMOG = Non-methane hydrocarbons or organic gases

(1) For diesel vehicles only (2) for alcohol fueled vehicles only (3) Total hydrocarbons (4) Carbon canister trap method (5) SHED (Sealed Housing Evaporative Determination) technique, the 6.0 g/test limit represents about 70 % less than 2.0 g/test by carbon trap method (6) values in parentheses for full useful life equal to 100,000 miles, (7) new limits (8) To be phased in between 2004-2009, limits for all types of light duty vehicles GVW

California Emission Standards for Passenger Cars, g/mile (1)

Year	NMOG/ NMHC	CO	NO _x	PM (1)	HCHO (2)	Evap- g/test
TLEV, 1996	0.125 (0.156)	3.4 (4.2)	0.4 (0.6)	(0.08)	0.015 (0.018)	2.0
LEV, 2000	0.075 (0.090)	3.4 (4.2)	0.2 (0.3)	(0.08)	0.015 (0.018)	2.0
ULEV, 2001	0.04 (0.055)	1.7 (2.1)	0.2(0.3)	(0.04)	0.015 (0.018)	2.0
LEV 2, 2004	0.075(0.090)	3.4 (4.2)	0.05 (0.07)	(0.01)	0.015 (0.018)	2.0
ULEV2,2004	0.040(0.055)	1.7(2.1)	0.05(0.07)	(0.01)	0.008 (0.011)	2.0
SULEV2, 2004	(0.010)	(1.0)	(0.02)	(0.01)	(0.004)	2.0
PZEV (7)	0.010	1.0	0.02	0.01	0.004	

(1) Limits in parentheses at the end of durability run for 100,000 miles and from the year 2004 at 120,000 miles.

(2) Partial zero emission vehicles (PZEV) limits are for 150,000 miles durability.

- European Standards European emission standards for the light duty vehicles are given in the Table 4.3. Before 1992 i.e. prior to Euro 1 standards, emission limits were based on ECE-15 cycle and varied with vehicle reference weight, the higher emissions were permitted for the heavier passenger cars. From 1992 however, the same limits for all the passenger cars irrespective of vehicle weight as in the US were introduced. EU standards up to Euro 3 stage require durability demonstration for 80,000 km or 5 years, whichever occurs first. In lieu of actual durability test, the manufacturers may use the following deterioration factors:
- Gasoline cars: 1.2 for CO, HC and NO_x
- Diesel cars: 1.1 for CO, NO_x and HC+ NO_x, 1.2 for PM
- Euro 5 stage requires durability of 160,000 km or 5 years, whichever occurs first. The emission standards for the light duty trucks and medium duty vehicles also, have been laid down and can be found in the European regulations

European Emission Standards for Passenger Cars, g/km

Description	Vehicle Type	CO	HC	NO _x	HC+NO _x	PM
1992 - Euro 1	All	2.72	-	-	0.97	0.14 (1)
		(3.16)			(1.13)	(0.18) (2)
1996 - Euro 2	Gasoline	2.2			0.50	
	Diesel IDI	1.0			0.70	0.06
	Diesel DI	1.0			0.90	0.10
2000 - Euro 3 (3)	Gasoline	2.3	0.20	0.15	-	-
	Diesel	0.64	-	0.50	0.56	0.05
	Gasoline	1.00	0.10	0.08	-	-
2005 - Euro 4	Gasoline	1.00	0.10	0.08	-	-
	Diesel	0.50	-	0.25	0.30	0.025
2009 - Euro 5	Gasoline	1.0	0.10 (4)	0.06	-	0.005 (5,6)
	Diesel	0.50	-	0.18	0.23	0.005 (5)
2014 - Euro 6	Gasoline	1.0	0.10 (4)	0.06		0.005 (5,6)
	0.50	-	0.08	0.17	0.17	0.005 (6)

- (1) PM limits apply only to diesel cars.
- (2) Values in parentheses are conformity of production (COP) limits. From Euro 2 standards type approval and COP limits are the same
- (3) 40s idle phase preceding test eliminated
- (4) 0.068 g/km NMHC (non-methane hydrocarbons)
- (5) Applicable only to lean burn gasoline direct injection engines
- (6) Likely to be reduced to 0.003 with new measurement method.

Since 1991/1992 when the European vehicles needed catalytic exhaust after treatment to meet the regulations drastic reductions in emission limits have been enforced. Relative emissions limits since 1990 (pre-Euro1) to Euro 4 limits are shown on Fig 4.8. The Euro 4 limits were only about 5 to 15 % of the pre 1990 limits. Beyond Euro 4 standards, drastic reductions in diesel NO_x and PM emissions are required. The diesel passenger car NO_x would be reduced to just 1/3 rd and PM to 1/5 th of Euro 4 limits.

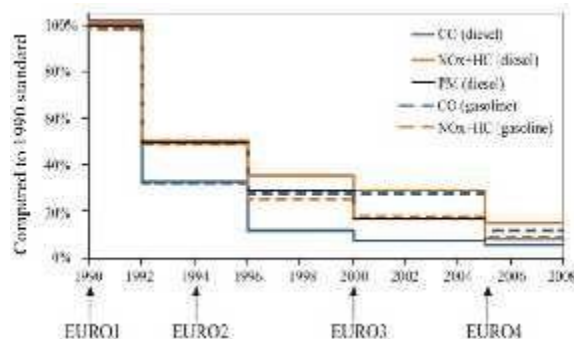

Evolution of EU emission standards (light duty)

Heavy Duty Engines

- Most heavy-duty vehicles are powered by the diesel engines. Hence, the heavy duty engine emission regulations have been directed more towards reduction in NO_x and PM emissions.

US Standards

- The US emission standards for the engines of heavy-duty vehicles (GVW >3855 kg) are given in Table 4.4. The emission limits applicable from the model year 2007 specify a drastic reduction over the year 2004 standards. The PM standards will be fully effective from the year 2007. The NO_x and NMHC standards are to be phased-in for the diesel engines between 2007 and 2010.
- Emission durability is to be demonstrated over the useful life of the vehicles that varies from 8 years or 176,000 km for light heavy-duty engine vehicles (>8,860 kg 15000 kg GVW). To make the year 2007 standards effective, diesel fuel sulphur is to be reduced to 15 ppm maximum down from the earlier limit of 500 ppm.

US Federal Heavy Duty Engine Emission Standards, g/bhp-h, (US HD-Transient cycle)

Year	CO	HC	NMHC + NO _x	NO _x	PM
1988	15.5	1.3	-	10.7	0.60
1990	15.5	1.3	-	6.0	0.60
1991	15.5	1.3	-	5.0	0.25 (0.25)
1994	15.5	1.3	-	5.0	0.10 (0.07)
1996	15.5	1.3	-	5.0	0.10 (0.05) ⁽¹⁾
1998	15.5	1.3	-	4.0	0.10 (0.05) ⁽¹⁾
2004 ⁽²⁾					
Option 1	15.5	-	2.4	-	0.10 (0.05)
Option 2	15.5	0.6 ⁽³⁾	2.5	-	0.10 (0.05)
2007	15.5	0.14 ⁽³⁾	-	0.2	0.01

Note: values in parentheses apply to urban buses

- (1) PM standard in use is 0.07 g/hp.h
- (2) Engine manufacturers may use either of the two options.
- (3) NMHC limits apply.

European Standards

- The European regulations for new production heavy-duty diesel engines since Euro 1 stage are given in Tables. These standards apply to both heavy-duty highway vehicles as well as to urban buses. The test cycle was changed with the implementation of Euro 3 standards in the year 2000. To meet the Euro 4 standards and beyond, diesel engines need some form of aftertreatment devices such as oxidation catalysts, particulate filters, de-NO_x catalysts etc.
- From Euro 3 regulations, heavy-duty engines operating on gaseous fuels are tested also on ETC in addition to ESC cycle. However, for compliance with Euro 4 or later standards, all heavy-duty engines are to meet ESC, ELR and ETC test limits. Evolution of European emission regulations for heavy duty vehicles is shown on Fig.

European Heavy Duty Diesel (CI) Engine Emission Standards – g/kWh (smoke in m⁻¹)

	Date & Category	Test cycle	CO	HC	NO _x	PM	Smoke
Euro1	1992 <85 kW	ECE R 49	4.5	1.1	8.0	0.61	
	1992 >85 kW		4.5	1.1	8.0	0.36	
Euro 2	Oct. 1996		4.0	1.1	7.0	0.25	
	Oct. 1996		4.0	1.1	7.0	0.15	
Euro 3	Oct. 2000	ESC & ELR	2.1	0.66	5.0	0.10	0.8
						0.13*	
Euro 4	Oct 2005	FSC& ELR	1.5	0.46	3.5	0.02	0.5
Euro 5	Oct 2008		1.5	0.46	2.0	0.02	0.5
Euro 6	Jan. 2013	ESC	1.5	0.13	0.4	0.01	-

*For engines of less than 0.75 litre /cylinder swept volume and rated speed of more than 3000 rpm.

Emission Standards for CI and SI Engines, ETC Test, g/kWh

	Date & Category	Test cycle	CO	NMHC	CH 4 ⁽¹⁾	NO _x	PM ⁽²⁾
Euro3	Oct. 2000	ETC	5.45	0.79	1.6	6.0	0.16
							0.21 ⁽³⁾
Euro 4	Oct. 2005		4.0	0.55	1.1	1.1	0.03
Euro 5	Oct. 2008		4.0	0.65	1.1	2.0	0.03
Euro 6	Jan. 2013		4.0	0.16 (4)	0.5	0.4	0.01 (5)

(1) for natural gas engines only; (2) not applicable for gas fuelled engines for approval to Euro 3 and Euro 4 standards; (3) for engines of less than 0.75 litre/cylinder swept volume and rated speed above 3000 rpm; (4) THC (total hydrocarbons) limits apply for diesel; (5) particle number limit may apply to prevent ultra fine particles from flow through (or partial flow) filters.

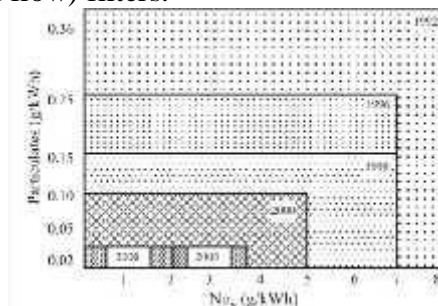

Evolution of European Heavy duty Emission Standards

Emission Standards in India

- India has adopted the European emission limits on a slightly modified driving cycle for the light duty vehicles. The overall emission limits and test procedures for the heavy duty vehicles however are the same as those in Europe . In India , the emission limits are being enforced by a time lag of around 5 years as shown in Table 4.7.

Indian Emission Regulations

(light duty emission standards with a modified EUDC - maximum speed limited to 90 km/h)

Year of Implementation	Level of European Emission Standards
2000	Euro 2: four metro cities (1)
	Euro 1: rest of the country
2005	Euro 2: seven more cities (2)
	Euro 3: thirteen cities
2010	Euro 2: rest of the country
	Euro 4: fifteen cities
	Euro 3: rest of the country

(1) Delhi , Mumbai, Kolkatta, Chennai

(2) Banglore, Hyderabad , Ahmedabad, Pune, Surat , Kanpur , Agra ; added from the year 2005- Sholapur and Lucknow

Motorcycle Emission Standards

Asian countries have a very large population of motorcycles and mopeds and these vehicles are estimated to contribute very heavily to urban air pollution. Taiwan and India have lead enforcement of stringent emission limits for two wheelers. Although the USA and Europe have implementd emission regulations for the two wheelers many decades back, but the number of these vehicles not being very large the standards were not tightened for a long time. However, now in these countries too very stringent limits are being enforced. Motorcycle emission standards in some countries are given in Table 4.8. Presently, most countries follow different test procedures. However, as discussed earlier, a world motorcycle test cycle has been developed and in future most countries are expected to use WMTC.

Worldwide Motorcycle Emission Standards

Country/Year/ Type of Motorcycle	Test Cycle	Emission Limits, g/hm				Durability, Kms
		CO	HC	NO _x	HC+NO _x	
USA						
< 150	FTR-75			-	-	-
200 < 279 CC		12.0	0.0			12,000-30,000
> 280 CC		12.0			1.1	6,000-18,000
2010 < 279 CC		12.0	0.0			
> 280 CC		12.0			0.8	
Europe						
2003 < 600 CC	ECE 47	1.0			1.2	
> 50 < 100 CC	FOP 40	5.5	1.0	0.3	-	-
> 100 CC		5.5	1.0	0.3		
2005 > 50 < 100 CC	FOP 40 (1)	2.0	0.8	0.15	-	-
> 100 CC	FOP 15 + F1/FC	2.0	0.3	0.18		
2007 < 150 km/h	WMTC	2.50	0.75	0.15	-	30,000
< 130 km/h max. Speed	(optional)	2.62	0.33	0.22	-	30,000
India , 2000						
	IDC (warm)	2.0			2.0	
2005 (P)	IDC	1.5			1.5	30,000
	(cold)					
2010 (2)	IDC (cold)	1.0			1.0	30,000

(1) Warm-up period before emission measurement of ECE 15 cycle eliminated.

(2) For catalyst equipped motorcycles an emission deterioration factor of 1.2 applies.

DIFFERENT TYPES OF EMISSION CONTROL DEVICES

POSITIVE CRANKCASE VENTILATION (PCV) SYSTEM

- There is many types of pollution control systems used on engines today. The Positive Crankcase Ventilation (PCV) system is one that is very popular. What is the PCV system, how does it work, and what type of pollution is being reduced?
- The positive crankcase ventilation system, referred to as the PCV system, was one of the first pollution control devices to be used on engines. Years ago, all engines had a “breather tube.” Its purpose was to remove crankcase vapors and gases from the engine. The breather tube allowed these vapors to go into the atmosphere as a known contributor to air pollution. Today, all engines use some variation of the positive crankcase ventilation system. The purpose of the PCV system is to stop crankcase vapors and gases, produced within the engine, from getting into the air.
- Crankcase vapors and gases in the engine are a result of piston blow-by. During combustion, a small amount of combustion vapors and gases pass by the piston rings and into the crankcase area. Referring to the illustration above, the crankcase vapors and gases are drawn into the intake of the engine by **the intake manifold vacuum**, to be further burned by the combustion.
- The PCV vacuum circuit works as follows. Air for the system enters the air cleaner area. The air then goes through the air filter, through a tube, and through the closed oil filler cap. The intake manifold vacuum then draws the crankcase vapors and gases back to the PCV valve. From the PCV valve, the vapors and gases are drawn into the intake of the engine to be burned by combustion.

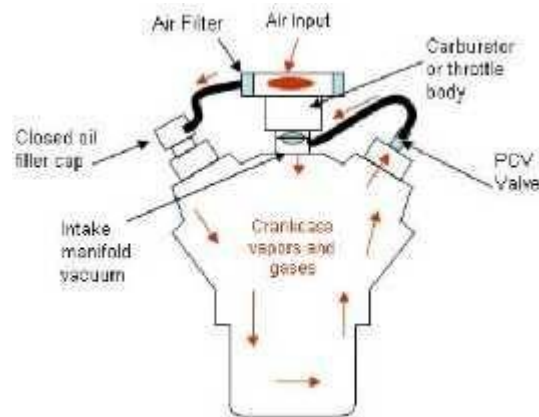

Positive Crankcase Ventilation

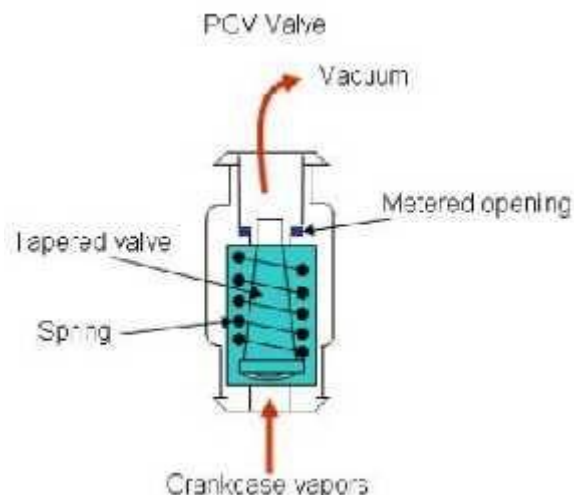

- If too many vapors and gases get into the intake manifold, it may upset the air-fuel ratio. The PCV valve helps to control the amount of vapors and gases going back into the intake manifold. A typical PCV valve is shown in the illustration to the left. In operation, two forces are working against each other. Spring pressure inside the PCV valve works against the intake manifold vacuum. When the engine is stopped, no intake manifold vacuum exists. At this point, the PCV valve is moved down by the spring inside.
- When the engine is decelerating or at an idle, intake manifold is very high. The intake manifold vacuum lifts the PCV tapered valve upward against the spring pressure. This reduces the size of the metered opening. Under this condition, very little crankcase vapors or gases enter the intake manifold.
- During normal loads and speeds, the vacuum in the intake manifold drops. This allows the inside spring to push the plunger down which increases the metered opening on the top of the valve. Under this condition, the amount of crankcase ventilation vapors and gases going into the intake manifold increases.
- During acceleration or heavy loads, the intake manifold vacuum is very low. The inside spring now pushes the tapered metering valve further down, allowing more crankcase vapors and gases to enter the intake manifold. In summary, when the engine is at low speeds, only a small amount of crankcase vapors and gases are sent into the intake manifold. As the engine increases in speed and load, more and more crankcase vapors and gases are allowed to enter the intake manifold.



- The photo to the left shows a typical PCV valve used on most engines. The arrow is pointing to the bottom of the metering valve. As mentioned above, when there is no intake manifold vacuum, the spring pushes the metering valve down. Even with the spring pressure, the valve doesn't go all the way down. If shaken back and forth, the PCV metering valve should rattle. If it doesn't, it is most likely plugged and needs to be replaced.

CATALYTIC CONVERTER

- There are millions of vehicles on roads today. Majority of them are run by internal combustion engines which become a major contributor to the air pollution. Especially in cities, where huge traffic is unavoidable can result in poor air quality that can affect not just the environment, but even our health.
- To solve this problem, the governments of different countries around the globe have taken necessary steps to implement stricter emission norms for vehicles. Catalytic converter is one of the devices that could lessen the intensity of harmful emissions coming out of a vehicle.

What is a Catalytic Converter?

- Catalytic converter is a device that converts harmful toxic emission gases from a vehicle into less harmful emission gases. The process is achieved either through oxidation or reduction. Catalytic converters can be used to treat exhaust gases of both gasoline and diesel engines.

2 way Catalytic Converters

- Unlike the [three way catalytic converter](#), 2-way catalytic converters are used to reduce CO and HC gases. 2 way converters don't eliminate or eliminate very little amount of NO_x. They are made of only oxidation catalysts (platinum (Pt) and palladium (Pd)).
- It is made of honeycomb ceramic structure with a coating of alumina. A secondary coat of precious materials, platinum and palladium is applied to the structure.

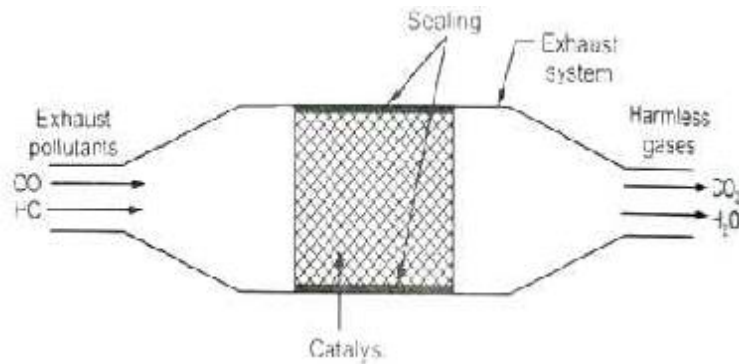

2 way catalytic converter

- The oxidation catalyst is honeycomb shaped structure made of platinum and palladium. Since, it is an oxidation reaction; the catalyst will try to attract the oxygen atoms. The CO bond is strong enough to be split by the catalyst.
- Thus CO molecule as a whole will be attracted towards the catalyst surface. The catalyst surface will also attract the oxygen molecules (O₂). Now, since O₂ molecules' bonds are weaker than the CO bond, the O₂ is split into individual oxygen atoms (O). The oxygen atoms will bond with the CO molecules to form CO₂.

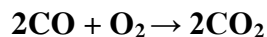

- The hydrocarbon (HC) molecules also get treated by the oxidation catalyst. When HC molecules come in contact with the catalyst surface, they are split into hydrogen (H) and carbon (C). Both hydrogen and carbon bond with oxygen to form water vapor (H₂O) and carbon dioxide (CO₂).

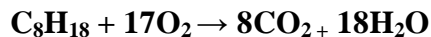

Or

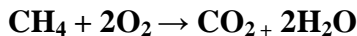

3-way Catalytic Converters:

- A 3-way catalytic converter is used to treat the 3 main harmful gases coming out of exhaust such as the nitrogen oxides (NO_x), hydrocarbons (HC) and carbon monoxide (CO) emissions.
- There are 2 different catalysts at work: one is the reduction catalyst and the other is the oxidation catalyst. The reduction catalyst is made of platinum and rhodium. The oxidation catalyst is made of platinum and palladium.

Alumina Coating:

- The catalysts are in the form of thousands of micro ducts that resemble the form of a honeycomb. The gases pass through these catalyst ducts. The honeycomb structure is applied with a coat of alumina (aluminum oxide).
- Alumina is highly porous which greatly increases the surface area of the structure. The alumina coat carries the precious catalyst materials which help in oxidation and reduction.
- This design maximizes the surface area of the catalyst, thus giving it more gases to react on.
- Catalytic converter is installed between exhaust pipe and muffler. It works best when it is heated and can give efficiency up to 90%. As a result, we get less harmful toxic gases from the tail pipe.

Working of a catalytic converter:

- The exhaust gases from the engine are first sent through the reduction catalyst. The reduction catalyst (platinum + rhodium) will try to eliminate NO_x as much as possible.

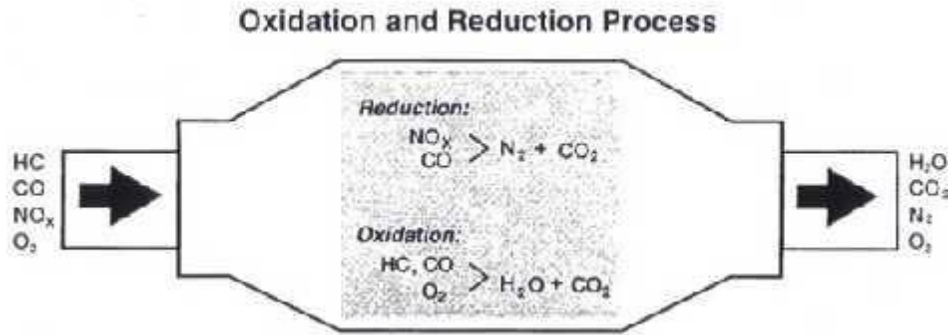

Reaction at reduction catalyst:

- When NO_x (NO or NO₂) molecules pass through the contact area, the catalyst breaks the bond between nitrogen and oxygen atoms. Since, it is a reduction reaction; the catalyst will try to get rid of oxygen atoms and would attract the nitrogen atoms.
- The individual oxygen atoms (O) pair up with other oxygen atoms (O) to form oxygen molecule (O₂). The nitrogen atoms (N) stick to the catalyst surface unless they find other nitrogen atoms (N) to bond with to form nitrogen molecules (N₂).

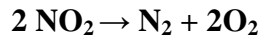
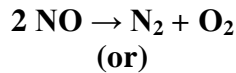

- The reduction catalyst won't eliminate the CO and HC molecules.

Reaction at oxidation catalyst:

- The oxidation catalyst is another honeycomb shaped structure made of platinum and palladium. Since, it is an oxidation reaction; the catalyst will try to attract the oxygen atoms. The CO bond is strong enough to be split by the catalyst.
- Thus CO molecule as a whole will be attracted towards the catalyst surface. The catalyst surface will also attract the oxygen molecules (O₂). Now, since O₂ molecules' bonds are weaker than the CO bond, the O₂ is split into individual oxygen atoms (O). The oxygen atoms will bond with the CO molecules to form CO₂.

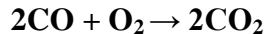

- The hydrocarbon (HC) molecules also get treated by the oxidation catalyst. When HC molecules come in contact with the catalyst surface, they are split into hydrogen (H) and carbon (C). Both hydrogen and carbon bond with oxygen to form water vapor (H₂O) and carbon dioxide (CO₂).

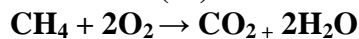
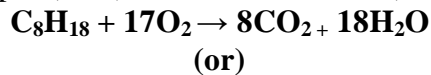

EXHAUST GAS RECIRCULATION (EGR)

- Exhaust Gas Recirculation (EGR) is an emission control system used to reduce NO_x emissions in particular. It redirects some amount of exhaust back to the combustion chamber of an engine to dilute the oxygen in the intake stroke and reduce the combustion temperature.
- NO_x is produced at peak engine temperature and the emission is higher when the oxygen content in the intake is high (lean mixture). At high temperatures, nitrogen combines with oxygen to form various oxides of nitrogen (collectively known as NO_x). NO_x is responsible for the formation of smog in cities.

Design and Operation of EGR:

- The exhaust from the engine is re-circulated only when a vacuum operated valve opens. The EGR valve is operated by the exhaust back pressure. At a particular back pressure range, EGR valve allows some amount of exhaust to be sent back to the combustion chamber.
- The exhaust gas is an inert gas, hence it cannot be burned. It dilutes the fresh air in the inlet manifold, thus reducing the oxygen content. The inert gases also absorb the combustion chamber heat to reduce the peak temperature.
- The exhaust gases pass through an EGR cooler to reduce its temperature. Reducing the temperature of exhaust helps in reducing the peak temperature of the cylinder.
- In an S.I. engine, EGR re-circulates 5 % to 15 % of the exhaust. Excess amount of recirculation can compromise engine efficiency. EGR is not used at engine idling speed to avoid unstable combustion. It is also not used at high loads as we require high power output to gain high speeds and EGR would just prevent high oxygen intake at high loads.
- In a diesel engine, exhaust can be re-circulated as high as 50 % as diesel engine is not subjected to continuous flame front and knocking.

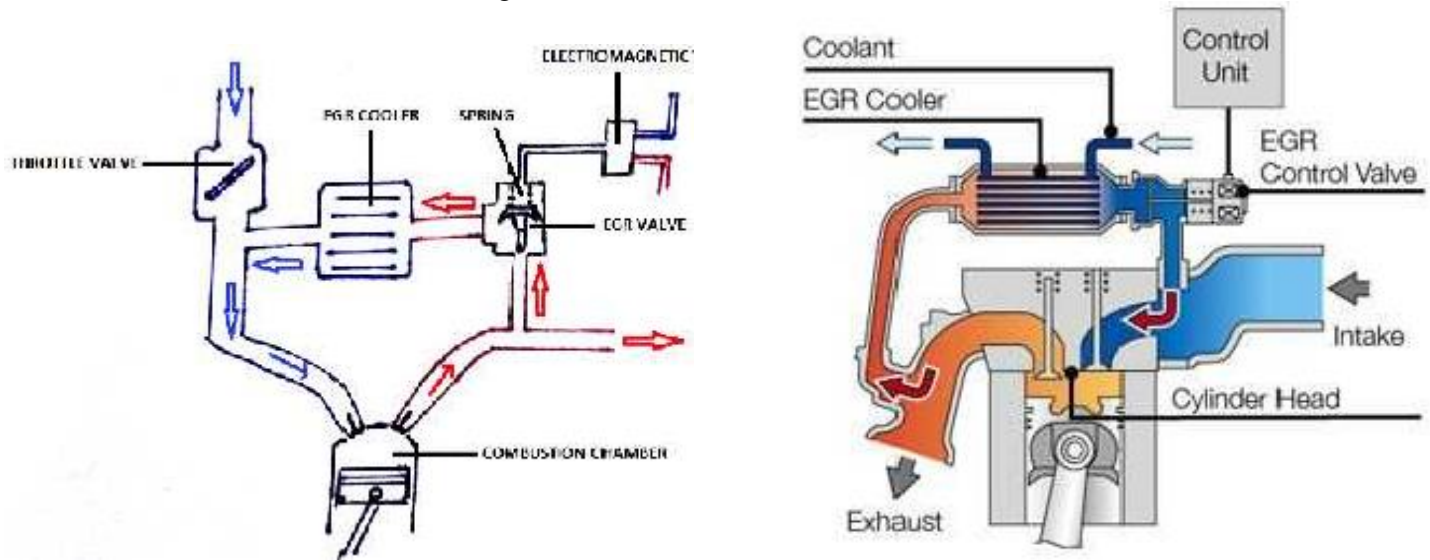

Exhaust Gas Recirculation

- In the mid-1990s, pneumatic EGR valves became more popular in EGR system. It consists of an electromagnetic valve which is operated by vacuum. Vacuum is usually generated by the pressure difference between inlet manifold and exhaust manifold.

EVAPORATIVE EMISSION CONTROL SYSTEM (OR) FUEL VAPOR CANISTER

- Canister is a pollution control device used mainly in gasoline fuel tanks to prevent the vapors of the fuel escape from the tank. Gasoline gets easily vaporized, and evaporated gasoline can increase the emissions because it is a mixture of hydrocarbons (HC) which is harmful for both environment and humans. This system is also known as **Evaporative Emission Control System (EVAP)** or **fuel vapor canister** or **carbon canister**.
- Fuel vapor canisters were first used in the mid-1970s and it significantly reduced the HC emissions. Gases escaping from the tank or engine result in HC emissions.
- To prevent the evaporated fuel to escape unburned, fuel vapor canister is used to trap all the vapors and then store and use it later when the engine is switched ON. A fuel vapor canister only works when the engine is OFF.

Design of Canister:

- There is an inlet port and an outlet port. The canister is filled with charcoal. The charcoal traps the gas and then sends it out via the outlet port.
- When the gasoline vaporizes, the vapors from the tank escape through a vent line and then reach the canister through the inlet port. The outlet port is connected to a purge valve which prevents the fuel from entering the inlet manifold unless the engine is switched ON.
- A carburetor vent line is provided for the fuel bowl in the carburetor. The fuel in the carburetor bowl will vaporize when the temperature rises. The vaporized fuel is supplied to the canister through the carburetor vent line.
- The canister is provided with a purge air line at the bottom which allows the air from the atmosphere to enter the canister and form a fuel-air mixture.

Working of a Fuel Vapor Canister:

- The evaporated gases reach the canister through the vent port and reach the carbon canister. The gases are trapped inside due to its properties to trap hydrocarbons. The gases are stored in the canister. When the engine is switched ON, suction is created in the intake manifold which prompts the purge valve to open and this allows the air to be sucked inside the canister through an air filter.
- The air from the purge air line pushes the gasoline vapors from the canister to the intake manifold. The air-fuel mixture is then supplied and burned inside the combustion chamber. The canister stops working when the engine is switched ON. Fuel vapor canister can only be used in a vehicle having a carburetor.

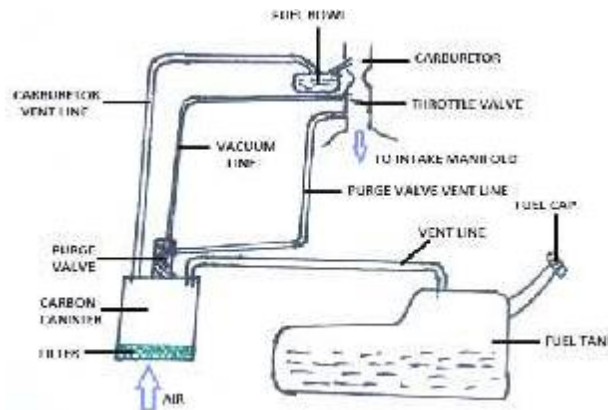

Evaporative Emission Control System

MULTI POINT FUEL INJECTION SYSTEM FOR SI ENGINES.

- In this system an electrically driven fuel pump draws fuel from fuel tank and supplies it to a common header or tube. A pressure regulator fitted at the end maintains a constant pressure of fuel approx. 3 bars in the header.
- The header is connected to different branches of inlet manifold through fuel injectors. For each cylinder of engine there is separate fuel injector which injects fuel in the corresponding air passage of that cylinder. Due to this the system is called multi-point fuel injection (MPFI) system.
- The fuel injectors are precision built solenoid valves having single or multiple orifices. Due to constant pressure of fuel maintained in the common header, the quantity of fuel injected depends only on the time period for which the solenoid valve type fuel injectors are kept in open position.
- An on-board ECU (Electronic control unit) i.e. microprocessor controls the quantity of fuel injected to each cylinder individually and also the ignition timing of each cylinder.
- The data input to the ECU comes from a number of sensors located all over the engine. These sensors collect the following data continuously.

1. Ambient temperature
2. Inlet manifold vacuum or Air Velocity
3. Exhaust gases temperature
4. Exhaust O₂ content
5. Throttle position
6. Engine r.p.m.
7. Crankshaft & position
8. Engine coolant temperature

- Based on programmed interpretation or processing of this data, ECU calculates the amount of fuel needed to maintain stoichiometry i.e. air/fuel ratio of 14.7:1 and converts it into required pulse width i.e. time period for which it keeps the solenoid injector energized.
- ECU also gives command to spark ignition system. In this way ECU ensures overall satisfactory performance of the engine from start to shut down including emission control by sending right quantity and quality of fuel air mixture to each cylinder of engine at right time based on requirement of engine and also ignites it at right time.

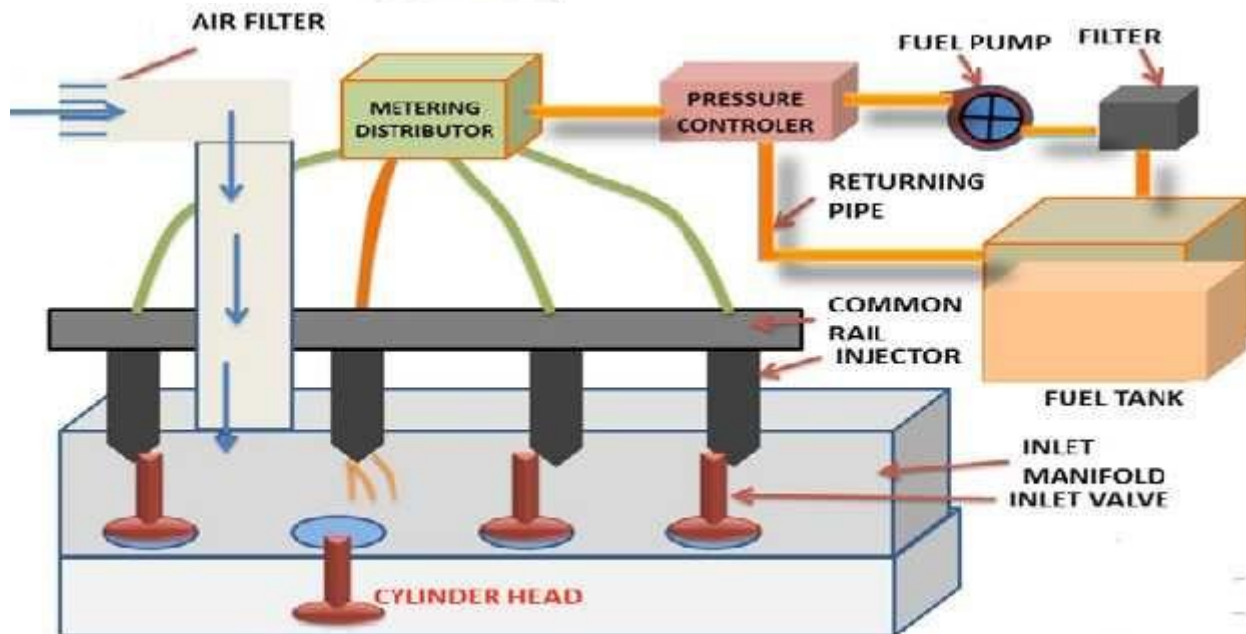
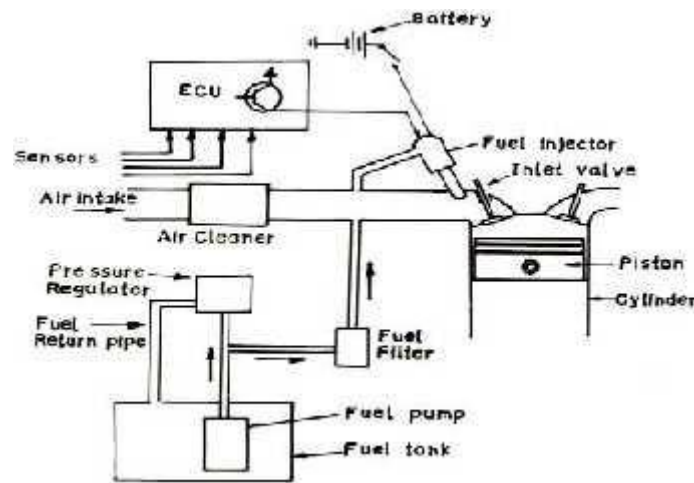

MPFI (Electronic fuel injection system)

Engine Sensors

In order to provide the correct amount of fuel for every operating condition, the engine control unit (ECU) has to monitor a huge number of input sensors. Here are just a few-

- **Mass airflow sensor** - Tells the ECU the mass of air entering the engine.
- **Oxygen sensor(s)** - Monitors the amount of oxygen in the exhaust so the ECU can determine how rich or lean the fuel mixture is and make adjustments accordingly
- **Throttle position sensor** - Monitors the throttle valve position (which determines how much air goes into the engine) so the ECU can respond quickly to changes, increasing or decreasing the fuel rate as necessary.
- **Coolant temperature sensor** - Allows the ECU to determine when the engine has reached its proper operating temperature
- **Voltage sensor** - Monitors the system voltage in the car so the ECU can raise the idle speed if voltage is dropping (which would indicate a high electrical load).
- **Engine speed sensor** - Monitors engine speed, which is one of the factors used to calculate the pulse width

Advantage of Electronic Fuel injection over carburetor:-

- Better atomization of fuel
- Lower emission of pollutant
- Better flow due to elimination of venturi
- Rapid response time with respect to the changes
- Improved fuel efficiency
- I guess this explains MPFI system in sufficient detail.

Advantages of multi point fuel injection system

- The multi-point fuel injection technology improves fuel efficiency of the vehicles. MPFI uses individual fuel injector for each cylinder, thus there is no gas wastage over time. It reduces the fuel consumption and makes the vehicle more efficient and economical.
- The vehicles with MPFI automobile technology have lower carbon emissions than a few decades old vehicles. It reduces the emission of the hazardous chemicals or smoke, released when fuel is burned. The more precise fuel delivery cleans the exhaust and produces less toxic byproducts. Therefore, the engine and the air remain cleaner.
- MPFI system improves the engine performance. It atomizes the air in small tube instead additional air intake, and enhances the cylinder-to-cylinder fuel distribution that aid to the engine performance.
- It encourages distribution of more uniform air-fuel mixture to each cylinder that reduces the power difference developed in individual cylinder.
- The MPFI automobile technology improves the engine response during sudden acceleration and deceleration.
- The MPFI engines vibrate less and don't require to be cranked twice or thrice in cold weather.
- It improves functionality and durability of the engine components.
- The MPFI system encourages effective fuel utilization and distribution. .

Other benefits of MPFI

- Smooth operations and drivability
- Reliability
- Competent to accommodate alternative fuels
- Easy engine tuning
- Diagnostic capability
- Initial and maintenance cost

COMMON RAIL FUEL INJECTION SYSTEM FOR SI ENGINES.

- In this system of diesel injection, a common rail diesel injection (CRDI) technology is used. It is more or less same as Common Rail System of Mechanical Injection but the difference comes in the control over

metering & timing of injectors which is done by an on-board computer system or electronic control unit. Thus it resembles with the operation of MPFI system of S.I engine.

- The basic system is same; there is a high pressure fuel pump which maintains high pressure in a common rail (steel tube) through high pressure regulator. But here the pressure maintained is very high of the order of 2000 bar as compared to 3-5 bars in MPFI system. The fuel injectors are very special either solenoid type or piezzo electric type which control the fuel injection from common rail to each cylinder very precisely.
- The opening time, pulse width etc of fuel injectors can be electrically controlled by the E.C.U. Here is the main advantage of system that the fuel can be injected in more than one pulse in a very controlled manner unlike only one pulse or one injection per cycle in the mechanical system.
- Here a pilot injection is done before the main injection for fast burning and less ignition delay of the fuel. It reduces the noise level very much and also ensures complete burning of fuel, high efficiency, low emission and good cold start.
- This new technology has considerably removed the demerits of diesel engines like high noise level, high pollution, difficulty in starting etc and improved fuel efficiency a lot. A schematic diagram of CRDI system is given here in fig.
- The CRDi technology works in tandem with the engine ECU which gets inputs from various sensors. It then calculates the precise quantity of fuel and timing of injection. The fuel system features components which are more intelligent in nature and controls them electrically / electronically. Additionally, the conventional injectors are replaced with more advanced, electrically operated, solenoid injectors. They are opened by an ECU signal, depending upon the variables such as engine speed, load, engine temperature etc.
- A Common Rail system uses a 'common-for-all-cylinders' fuel-rail or in simple words a 'fuel distribution pipe'. It maintains optimum residual fuel pressure and also acts as a shared fuel reservoir for all the injectors. In the CRDi system, the fuel-rail constantly stores and supplies the fuel to the solenoid valve injectors at the required pressure. This is quite opposite to the fuel injection pump supplying diesel thru' independent fuel lines to injectors in case of earlier generation (DI) design.

Components of Common Rail Direct Injection System

1. High Pressure Fuel Pump
2. Common Fuel Rail
3. Injectors
4. Engine Control Unit

The working principle of Common Rail Direct Injection -

- A high-pressure pump supplies pressurized fuel. The pump compresses the fuel at the pressures of about 1,000 bar or about 15,000 psi. It, then, supplies the pressurized fuel via a high-pressure pipe to the inlet of the fuel rail. From there, the fuel-rail distributes the fuel to individual injectors which then inject it into the combustion chamber.
- Most modern CRDi engines use the Unit-Injector system with Turbocharger which increases power output and meets stringent emission norms. Additionally, it improves engine power, throttle response, fuel efficiency, and controls emissions. Barring some design changes, the basic principle & working of the CRDi technology remains primarily the same across the board. However, its performance depends mainly on the combustion chamber design, fuel pressures and the type of injectors used.

Advantages

The common rail diesel engine allows for better emission control and consumption of fuel and power. In other words, common rail diesel engines can deliver more power to the vehicle while consuming less fuel and producing fewer emissions. For these reasons, it complies with government regulators who want to put a cap on the volume of carbon emissions produced by a vehicle.

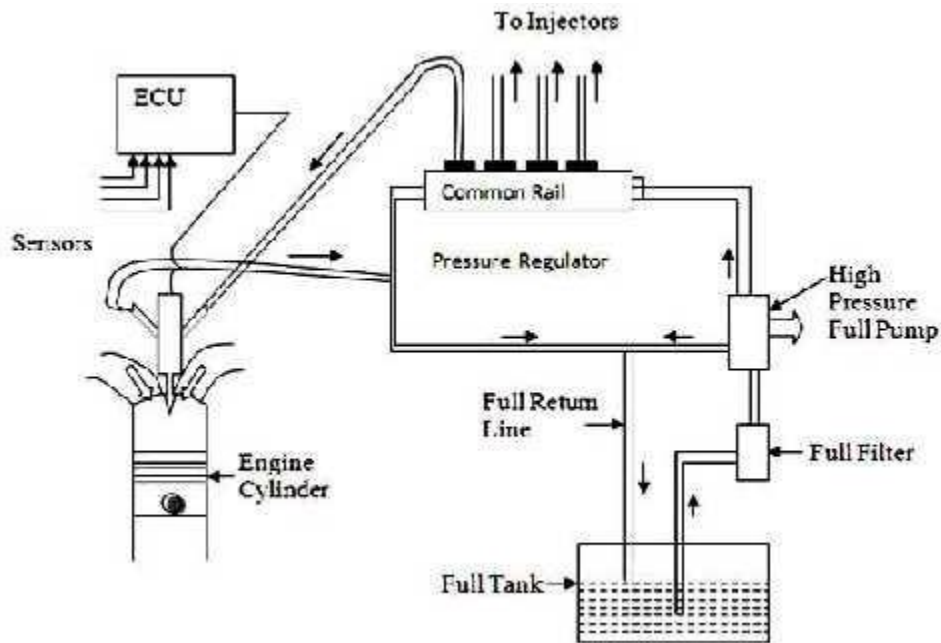
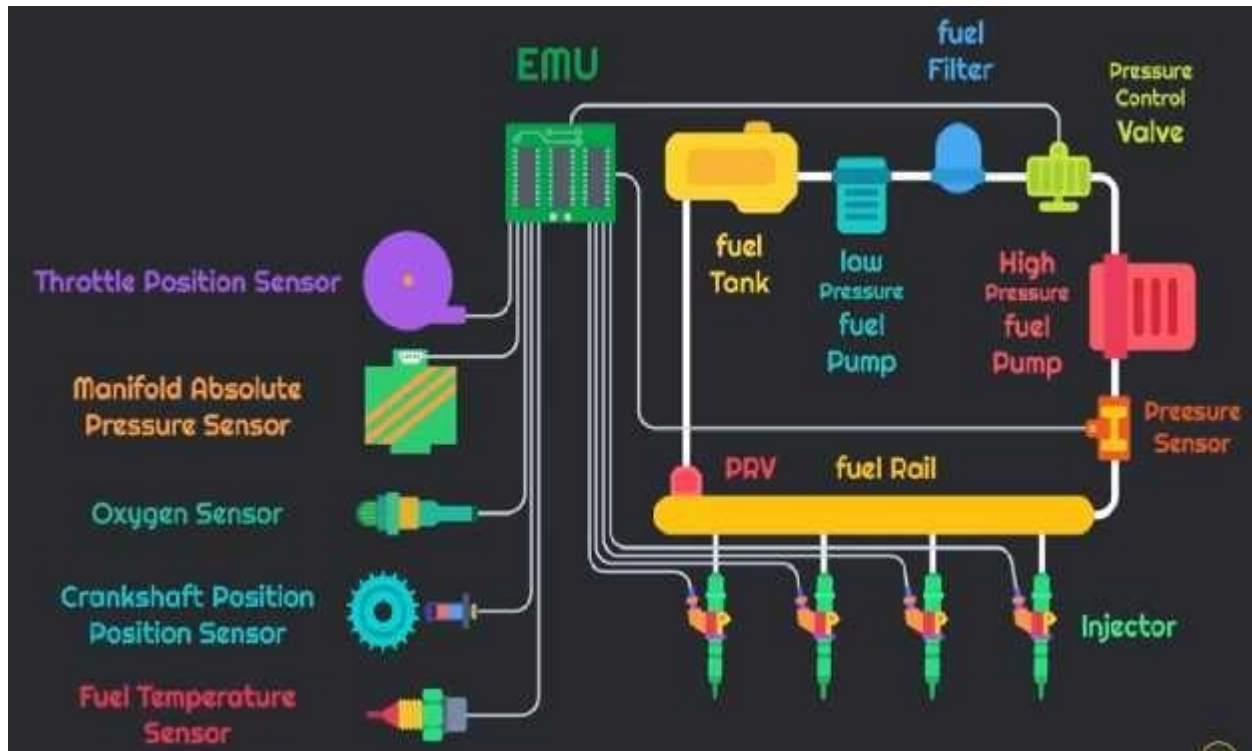

Common rail diesel injection system

Below is a list of the 5 main advantages.

1. **Lower Emissions** – One of the reasons that common rail diesel engines were invented by vehicle manufacturers was because the government created stricter regulations on carbon emissions. Remember when big diesel trucks used to release a lot of black smoke into the air? You hardly see that anymore because the common rail diesel engine is designed to reduce those emissions. This is better for the environment and is one step closer to fighting global warming.

2. **More Power** – Studies have shown that vehicles with a common rail diesel engine will produce 25% more power than a traditional diesel engine. This means the overall performance of the diesel engine will be improved.
3. **Less Noise** – Direct fuel injection systems were known for being noisy while driving. The common rail will reduce a lot of the noise that you might remember hearing. This makes it a more pleasant driving experience for you and those around you on the road.
4. **Fewer Vibrations** – There used to be a lot of vibrations felt in traditional direct fuel diesel engines. Now those vibrations have been reduced with the common rail direct injection system.
5. **Better Mileage** – Since the common rail diesel engine provides more power, that means you will get better mileage on your fuel. As a result, your fuel economy will be better as well. This means less money spent on fuel when you're on the road.

Disadvantages

With all the advantages of the common rail diesel engine, there are some disadvantages as well. Although there are fewer disadvantages, they may affect your decision of whether to purchase a common rail diesel engine-powered vehicle or not.

Below are the top 3 disadvantages.

1. **Expensive Vehicle** – Vehicles with a common rail diesel engine are going to be more expensive than those with the traditional diesel engine. If you're working for a company that supplies you with the vehicle, then it is no sweat. But if it is a personal vehicle, then you may not want to spend the extra money.
2. **Expensive Parts** – Since the common rail vehicles are more expensive, you can expect that replacement parts are going to be expensive as well.
3. **More Maintenance** – Common rail diesel engines will need more maintenance than a traditional diesel engine. Even if you do the maintenance yourself, it still takes more time, effort, and possibly expense. The common rail diesel engine is certainly an advancement in diesel technology that will eventually replace the traditional direct injection system altogether. Perhaps when this new technology becomes more common in every diesel-powered vehicle, then it will become less expensive. Until then, you will be making an investment into an engine that gives you better performance, better mileage, better driving experience, and promotes an environmentally friendlier agenda.

The benefits of common rail

- Noise, vibration and harshness (NVH) are improved with CRDi as a result of the timing flexibility. Your engine sounds quieter and has a better quality of sound. It also runs smoother. You will see fuel consumption benefits as well because greater injection pressure produces a finer spray of fuel (atomisation) that burns more efficiently.
- Better combustion efficiency is a key part of meeting emission standards. Less fuel is wasted as soot or particulates in the exhaust and deposits in the engine. A cleaner running engine is good for the environment – and for the cost of ownership. Cleaner running improves the long-term durability and reliability of your engine.
- We have designed our engines to deal with more stringent operating requirements. For example, improved fuel filtration ensures a higher level of purity in the fuel injected from the common rail. Clean servicing procedures are necessary to keep your engine running efficiently and within the limits of the applicable emission standards.

HYDROGEN:

- Clean burning fuel and has the highest energy content per unit mass of any chemical fuels which can reduce the dependency on hydrocarbon based fuels

Production:

- Most common method of producing hydrogen involves splitting water (H₂O) into its component parts of hydrogen (H₂) and oxygen (O). There are different methods to produce hydrogen-
 - ❖ **Steam reformation or partial oxidation of hydrocarbons** such as natural gas, naphtha or crude oil. It converts methane into hydrogen and carbon monoxide by reaction with steam over a nickel catalyst.
 - ❖ **Coal gasification-** Hydrogen made from coal can probably be justified as a fuel for special applications where the unique characteristics of hydrogen can be put to advantage such as its weight or its non-polluting characteristics.
 - ❖ **Electrolysis-** it uses electrical current to split water into hydrogen at the cathode (+) and oxygen at anode (-).
 - ❖ **Thermo chemical method-** it utilizes heat to achieve the chemical splitting of water to its elements without the need for intermediate electricity generation and without the need to use the extremity high temperature of 2500 °C or more.
 - ❖ **Photo-electrolysis-** it uses sunlight and catalysts to split water. In this method, a current is generated by exposing on or both electrodes to sunlight. Hydrogen and oxygen gases are liberated at the 2 electrodes by the decomposition of water. A catalyst may be included to facilitate the electrode process.
 - ❖ **Biological and photo-biological** water splitting use sunlight and biological organisms to split water.
 - ❖ **Thermal** water splitting uses a very high temperature (approximately 1000 °C) to split water.
 - ❖ **Biomass gasification** uses selected microbes to break down a variety of biomass feed stocks into hydrogen.

Utilization of hydrogen gas:

Hydrogen can be utilized for the following purpose:

- ❖ **Residential use-** hydrogen can be used in domestic cooking (stoves), radiant space heaters, electricity for lighting and for operating domestic appliances (e.g. refrigerator) which could be generated by means of fuel cells, with hydrogen gas at one electrode and air at other.
- ❖ **Industrial use-** hydrogen can be used as a fuel or a chemical reducing (i.e. oxygen removal) agent. It can also be used instead of coal or coal derived gases, to reduce oxide ores (iron ore) to the material (iron).
- ❖ **Air craft application-** The earliest application of liquid hydrogen fuel is expected to be in a jet air craft. Cold liquid hydrogen can be used directly or indirectly to cool the engine and the air frame surfaces of a high speed air craft.
- ❖ **Electric power generation-** It comprises the production of electricity by using hydrogen in fuel cell system. Hydrogen could also be used as a means for storing and distributing electrical energy. The objective of developing fuel cell power stations is to centralized and local generation of electricity.
- ❖ **As an alternative transport fuel-** Hydrogen is tried as an alternative fuel in internal combustion engine. The stoichiometric hydrogen air mixture burns seven times as fast as the corresponding gasoline air mixture which is a great advantage in internal combustion engines, leading to higher engine speeds and greater thermal efficiency . Hydrogen fuel used in IC engines is in automobiles, buses, trucks and farm machinery.

Advantages of using Hydrogen fuelled engine

- It provides high efficiency because it utilizes a higher proportion of the energy in the fuel.
- The amount of carbon monoxide and hydrocarbons in the exhaust is very small since they are originating only from the cylinder lubricating oil.
- It can be easily available because it is produced by electrolysis of water.
- Fuel leakage to environment is not pollutant.

Disadvantages of using Hydrogen fuelled engine

- Due to high heat release the combustion temperature may be high and also a level of nitrogen oxide is high. It can be reduced by reducing the combustion temperature by injecting water vapor into the cylinder from the exhaust.
- It requires heavy, bulky fuel storage both in vehicle and at the service station.
- Difficulty in refueling and possibility of detonation.
- Poor engine volumetric efficiency- gaseous fuel will displace some of inlet air and poor volumetric efficiency will result.
- Fuel cost would be high at present day technology

BIO MASS

What is biomass? What is bioenergy?

- Biomass is fuel that is developed from organic materials, a renewable and sustainable source of energy used to create electricity or other forms of power. Bioenergy – or biopower – is carbon neutral electricity generated from renewable organic waste that would otherwise be dumped in landfills, openly burned, or left as fodder for forest fires.
- Biomass can be made from agricultural and forestry residues and some industrial wastes and crops grown solely for energy purposes. Biomass is an attractive fossil-fuel alternative because it is a renewable resource that is more evenly distributed over the Earth's surface than finite fossil-fuel energy sources such as coal, oil and natural gas, and may be developed using more environmentally friendly technologies.

biomass used

- People have used biomass for heating and cooking for thousands of years – if you have a fireplace in your house, or have ever cooked over a campfire, you have used biomass. With today's technology, plant materials can be used to generate electricity, heat, or liquid fuels for motor vehicles that have substantially lower environmental impacts than traditional fossil fuels.

electricity created with biomass

- Direct combustion is the simplest and most common method of capturing the energy contained within biomass. In biomass power plants, wood waste or other waste is burned to produce steam that runs a turbine to provides electricity and heat to industries and homes.
- Fortunately, new technologies — including pollution controls and combustion engineering — have advanced to the point that any emissions from burning biomass are generally less than those produced when using fossil fuels (coal, natural gas, oil). ReEnergy has included these technologies in its facilities.
- Direct combustion technology is very similar to that used for coal, but biomass does not have the elements like sulfur and mercury that are found in coal, and its emissions are therefore safer.

bioenergy renewable

- Yes. At ReEnergy, we are creating renewable energy every day. Because we will always have wood waste — either from forest residue or from other sources — we will always be able to make biomass fuel to power our renewable electricity generation facilities. Biomass that is created from other waste is renewable because we will always have waste.

Biomass contribute to an increase in greenhouse gases

- No. As a renewable and reliable energy source, biomass can be used to generate energy on demand with virtually no net contributions to global greenhouse gas.
- Burning biomass to create clean electricity releases no new carbons back into the atmosphere. Instead, it releases what would be released naturally as the organic matter decomposed.
- It forms a closed cycle, too, because the carbon that is released when biomass is burned is re-absorbed by other plants in their growing cycle. When fossil fuels are burned, they release carbon that has been trapped for centuries, adding carbon into the atmosphere that had been unavailable underground.

- So, by burning biomass fuels we release no more carbon dioxide than would have been produced in any case by natural processes such as crop and plant decay. And, provided our consumption of biomass does not exceed our ability to continually supply the biomass feedstock we use, we have a renewable energy source whose use does not substantially disturb the natural biochemical cycle on a human time scale.

over-harvesting trees and plants to make biomass fuel

- Biomass power does not pose a threat to forests, farmland or crops. It is not economically viable for a biomass power plant to clear forests or chop down trees solely for the purpose of converting the trees into biomass to make electricity. Biomass is most cost effectively made from crops specifically planted for that purpose or from residuals of paper mills, wood collected from the forest floor, tree trimmings and remainder wood from current, sustainable logging practices.
- In comparison to fossil fuels, which take millions of years to be produced, plants that make up biomass are easy to grow, collect, utilize and replace quickly without depleting natural resources.

The benefits of using biomass for energy generation

- As with many other renewable energy sources, biomass is capable of simultaneously addressing the nation's energy, environmental, and economic needs. Increased use of biomass for energy would lead to reduced greenhouse gas emissions, reduced dependence on foreign oil, an improved U.S. balance of trade, an improved rural economy, and the creation of a major new American industry with the potential to employ tens of thousands.

The environmental benefits of biomass

- The use of biomass energy provides a multitude of environmental benefits. It can help mitigate climate change; reduce acid rain; prevent soil erosion and water pollution; minimize pressure on landfills; provide wildlife habitat; and help maintain forest health through better management.
- The use of biomass will reduce the nation's greenhouse gas emissions. Fossil fuels emit vast quantities of carbon dioxide into the atmosphere upon combustion, carbon that would otherwise remain trapped underground. Biomass also releases carbon dioxide as it burns, but the carbon dioxide released during combustion was absorbed during the plant's life, and would eventually be released as the organic matter decays, to be absorbed by other plants that are in the growth stages – thus creating a closed-carbon cycle.

The benefits for agricultural and forest land

- The nation has many vast tracts of unused agricultural land — the byproduct of increasingly efficient agricultural techniques — that could be reclaimed to grow plants for biomass, rather than have that land be converted to residential or industrial use. These lands that grow biomass crops will restore soil carbon, reduce erosion and chemical runoff, and enhance wildlife habitat.

Impact could biomass have on our domestic energy supply

- Biomass currently provides about 4 percent of the electricity produced in the United States, and, according to biomass power associations, it could easily supply 20 percent. As a result of the available land and agricultural infrastructure this country already has, biomass could conceivably replace all of the power that nuclear plants generate and do so in a sustainable fashion.

The **plant biomass energy** is transformed by three processes, which can be grouped into **three major groups**:

- thermo-chemical
- biological
- physical

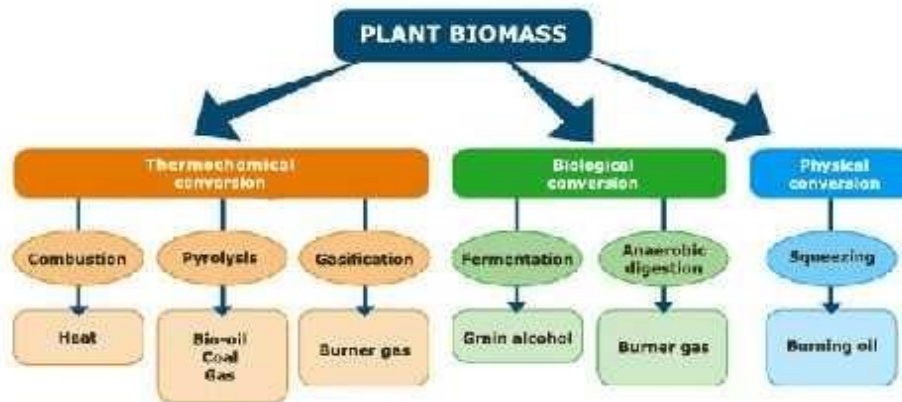

Different processes such as **combustion**, **pyrolysis** and **gasification** can generate the thermochemical conversion of the plant biomass energy. The biological conversion can be obtained by the alcoholic fermentation and digestion, while the physical **conversion by squeezing**.

COMBUSTION

➤ Combustion is the more traditional process for the conversion of biomass. To be efficient, it requires a reduction of the water content of the biomass, obtained by drying the products to the sun. In Italy there are about 40 large **systems generating biomasses electricity by combustion** - generally turning residues from wood processing - for a total electrical power of about 330 MW. They are, indeed, co-generation plants: final energy is given by heat and electrical energy. Part of the heat produced is in fact used to produce steam, employed to power the turbines connected to electric generators. The part of the remaining heat can be used for industrial or residential users. The efficiency of these systems is of 20-25%, so it's rather modest.

PYROLYSIS

➤ Pyrolysis is a process for thermochemical decomposition of organic material, also called dry distillation, which is based on the transformation of biomass through heat, in strong oxygen deficiency. Pyrolysis can be applied to any organic material with low water content (<15%). The material is brought to temperatures between 200 and 700° C, and sometimes appropriate amount of oxygen can facilitate the inception of a partial combustion, which leads to a rising of temperature.

GASIFICATION

➤ The **biomass gasification process** is a physical chemical process that occurs when a solid fuel (wood, biomass) is transformed in a gaseous fuel. The process consists in an incomplete oxidation of carbonaceous compounds brought to high temperature (about 1000 ° C), in an oxygen-deficient environment. The gas obtained, called syngas, can be used directly to power internal combustion engines, mainly employed for the production of electricity. The syngas is a mixture of nitrogen, methane, hydrogen, carbon monoxide and other gases. The conversion of plant biomass energy through biochemical processes can be split into two processes:

- ❖ Alcoholic fermentation;
- ❖ Anaerobic digestion.

FERMENTATION

➤ Alcoholic **Fermentation** is a biochemical transformation process in which sugars are converted into ethyl alcohol. The production of ethanol from biomass with high sugar content has been fully tested: in Brazil the fermentation of sugar cane allows to obtain ethanol at a price that might be compared to the gasoline one. In Italy some sugar beet experiences have been made, but with poor results: processing costs were not convenient.

ANAEROBIC D

- **Anaerobic digestion** is a process of conversion done by bacteria operating in a rich cellulose biomass; this process allows to obtaining a biogas containing about 65% methane. This gas is used to fuel an internal combustion engine connected to an electric generator. The electricity produced is directly fed into the distribution network and sold at remunerative price (Green Certificate), as obtained from a renewable energy source. The digested residual component can be used as fertilizer. These kind of biomass power plants are very common in Northern Europe.
- To better optimize the plants' performance, it may be convenient to get special device to use the produced heat, as for each kWh you get about 1 kWh of thermal energy.

SQUEEZING

- The **physical conversion** is essentially a process of mechanical pressing of crops with high oil content (sunflower rapeseed, soybean). The end results are some edible squeezing oil and protein panels containing a higher percentage of oil (10% max), used by the animal feed industry.
- The vegetable oil thus obtained, which is a mixture of methyl esters of fatty acids, can be used directly as fuel for diesel engines slightly modified, or be chemically treated to make it similar to **diesel fuel** (biodiesel).

(C) ALCOHOLS

- These include methanol (methyl alcohol), ethanol (ethyl alcohol), propanol (propyl alcohol), butanol (butyl alcohol) as compounds
- The OH group which replaces one of the H atoms in an alkane, gives these compounds their characteristic properties
- Specific heating value is lower than gasoline (42 – 43 MJ/kg)
- methanol (19.7 MJ/kg) and ethanol (26.8 MJ/kg)
- For air-fuel mixture SHV is comparable with gasoline (MJ/kg-mixture at stoichiometric mixtures)
- Other alcohol groups such as dihydric and trihydric alcohols are not used as a fuel in IC engines

(i) Methanol

- ❖ Can be obtained from natural gas – has near and long-term potential
- ❖ Has high octane quality (130 RON, 95 MON)
- ❖ Can be used in low-concentration (5-15 %) in gasoline to increase octane number of the mixture
- ❖ Problems
- ❖ Poor solubility in gasoline, toxicity, low energy content (about half of gasoline), high latent heat of vaporization and oxygen content
- ❖ Contribute to poor driveability, incompatibility with some metals

(ii) Ethanol

- ❖ Produced from biomass
- ❖ It is made from the sugars found in grains, such as: Corn, Sorghum, and Barley
- ❖ Other sources of sugars to produce ethanol include: Potato skins, Rice, Sugar cane, Sugar beets, Yard clippings, Bark, Switch grass etc.
- ❖ Has high octane number – can be used in low-concentrations in gasoline
- ❖ Most of the ethanol used in the United States today is distilled from corn
- ❖ Scientists are working on cheaper ways to make ethanol by using all parts of plants and trees rather than just the grain.
- ❖ About 99% of the ethanol produced in the United States is used to make "E10" or "gasohol," a mixture of 10% ethanol and 90% gasoline.
- ❖ Any gasoline powered engine can use E10, but only specially made vehicles can run on E85, a fuel that is 85% ethanol and 15%

LPG (LIQUEFIED PETROLEUM GAS)

- -LPG is available in the market in two forms- one is propane and the other is butane. Propane is popular alternative fuel because of its infrastructure of pipe lines, processing facilities and storage for its efficient distribution and also it produces fewer emissions. Propane is produced as a byproduct of natural gas processing and crude oil refining
- -Natural gas contains LPG, water vapor and other impurities and about 55% of the LPG is compressed from natural gas purification. LPG is a simple mixture of hydrocarbon mainly propane/propylene (C3S) and butane/ butylenes (C4S)
- -Propane is an odorless, nonpoisonous gas which has lowest flammability range.

UTILIZATION OF LPG

- LPG is used as a fuel in heating appliances and vehicles. It is increasingly used as an aerosol propellant and a refrigerant, replacing chlorofluorocarbons in an effort to reduce damage to the ozone layer
- -In Europe, LPG is used as an alternative to electricity and heating oil (kerosene).It can also be used as power source for combined heat and power technologies (CHP). CHP is the process of generating both electrical power and useful heat from a single fuel source. This technology has allowed LPG to be used not just as fuel for heating and cooking, but also for de-centralized generation of electricity
- -LPG has higher potential as an alternate fuel for IC engine.

Advantages of LPG

- Emission is much reduced by the use of LPG.
- LPG mixes with air at all temperatures.
- Uniform mixture can be supplied to all cylinders of multi-cylinder engine.
- Engine with high compression ratio (10:1) can use propane.
- There is cost saving of about 50% and longer life with LPG running engine.

Disadvantages of LPG

- A good cooling system is necessary because LPG vaporizer uses engine coolant to provide the heat to convert the liquid LPG to gas .
- The weight of vehicle is increased due to the use of heavy pressure cylinder for storing LPG.
- A special fuel feed system is required for LPG.
- Requirement of safety device to prevent accident due to explosion of gas cylinders or leakage in the gas pipes.

CNG (Compressed Natural Gas)

- Natural gas consists of elements of compressor, some sort of compressed gas storage and dispensing unit of CNG into vehicles
- Two types of CNG refueling system- slow fill and fast fill.
- In slow fill system, several vehicles are connected to the output of the compressor at one time. These vehicles are then refilled over several hours of compressor operation.
- In fast fill systems, enough CNG is stored so that several vehicles can be refueled one after the other, just like refueling from a single gasoline dispenser
- The storage system of CNG is arranged as several tanks in cascade form. The CNG pressure in cascade is higher than the maximum storage pressure of the cylinder on the vehicle. The cascade attempts to deliver as much of its CNG to vehicles as possible before the pressure difference decreases to where the flow rate slows dramatically.
- A dryer should include in most CNG refueling systems to remove water vapor, impurities and hydrogen sulphide from natural gas before it is compressed. If water vapor is present then it can condense in the

vehicle fuel system, causing corrosion especially if hydrogen sulphide is present. CNG driven vehicles with catalytic converter have less CO and HC emission but NO_x emission is high

Advantages

Some clear advantages to natural gas are as follows:

- Natural gas is environmentally friendly because it burns cleaner than other fossil fuels.
- It's safer and easier to store when compared to other fossil fuels.
- Natural gas is extremely **reliable**, unlike electric **power** that can be knocked out during a storm.

Disadvantages

There are many advantages as well as **disadvantages of CNG** bi fuel system. ...

- Environment Friendly:
- **CNG** is clean fuel. Natural gas produces very less hydrocarbon emissions than LPG and petrol.
- **CNG** is Economic: **CNG** is cheaper than petrol and LPG.

CHARGING SYSTEM

- The modern charging system hasn't changed much in over 40 years. It consists of the alternator, regulator (which is usually mounted inside the alternator) and the interconnecting wiring.
- The purpose of the charging system is to maintain the charge in the vehicle's battery, and to provide the main source of electrical energy while the engine is running.
- If the charging system stopped working, the battery's charge would soon be depleted, leaving the car with a "dead battery." If the battery is weak and the alternator is not working, the engine may not have enough electrical current to fire the spark plugs, so the engine will stop running.
- If the battery is "dead", it does not necessarily mean that there is anything wrong with it. It is just depleted of its charge. It can be brought back to life by recharging it with a battery charger, or by running the engine so that the alternator can charge it.
- These components make up the charging system:
 - ❖ Alternator
 - ❖ Voltage regulator
 - ❖ Battery
 - ❖ Charging Indicator
- The main component in the charging system is the **ALTERNATOR**. The alternator is a generator that produces Alternating Current (AC), similar to the electrical current in your home. This current is immediately converted to Direct Current (DC) inside the alternator. This is because all modern automobiles have a 12 volt, DC electrical system.
- A **VOLTAGE REGULATOR** regulates the charging voltage that the alternator produces, keeping it between 13.5 and 14.5 volts to protect the electrical components throughout the vehicle.
- There is also a system to warn the driver if something is not right with the charging system. This could be a dash mounted voltmeter, an ammeter, or more commonly, a warning lamp. This lamp is variously labeled "Gen" "Bat" and "Alt.". If this warning lamp lights up while the engine is running, it means that there is a problem in the charging system, usually an alternator that has stopped working. The most common cause is a broken alternator drive belt.
- The alternator is driven by a belt that is powered by the rotation of the engine. This belt goes around a pulley connected to the front of the engine's crankshaft and is usually responsible for driving a number of other components including the water pump, power steering pump and air conditioning compressor. On some engines, there is more than one belt and the task of driving these components is divided between them. These belts are usually referred to as: Fan Belt, Alternator Belt, Drive Belt, Power Steering Belt, A/C Belt, etc. More common on late model engines, one belt, called a Serpentine Belt will snake around the front of the engine and drive all the components by itself.

- On engines with separate belts for each component, the belts will require periodic adjustments to maintain the proper belt tension. On engines that use a serpentine belt, there is usually a spring loaded belt tensioner that maintains the tension of the belt, so no periodic adjustments are required. A serpentine belt is designed to last around 30,000 miles. Check your owner's manual to see how often yours should be replaced.
- Alternator output is measured in both voltage and amperage. To understand voltage and amperage, you must also know about resistance, which is measured in ohms. An easy way to picture this is to compare the movement of electricity to that of running water. Water flows through a pipe with a certain amount of pressure. The size (diameter) of the pipe dictates how much resistance there will be to the flowing water. The smaller the pipe, the more resistance. You can increase the pressure to get more water to flow through, or you can increase the size of the pipe to allow more water to flow using less pressure. Since too much pressure can burst the pipe, we should probably restrict the amount of pressure being used. You get the idea, but how is this related to the flow of electricity?
- Well, voltage is the same as water pressure. Amperage is like the amount or volume of water flowing through, while resistance is the size of the wire transmitting the current. Since too much voltage will damage the electrical components such as light bulbs and computer circuits, we must limit the amount of voltage. This is the job of the voltage regulator. Too much water pressure and things could start breaking. Too much voltage and things could start burning out.
- Now, let's go a little deeper and see how these charging system components actually work to produce the electrical power that a modern automobile requires.

Alternator

- The alternator uses the principle of electromagnetism to produce current. The way this works is simple. If you take a strong magnet and pass it across a wire, that wire will generate a small voltage. Take that same wire and loop it many times, than if you pass the same magnet across the bundle of loops, you create a more sizable voltage in that wire.
- There are two main components that make up an alternator. They are the rotor and the stator. The rotor is connected directly to the alternator pulley. The drive belt spins the pulley, which in turn spins the rotor. The stator is mounted to the body of the alternator and remains stationary. There is just enough room in the center of the stator for the rotor to fit and be able to spin without making any contact.
- The stator contains 3 sets of wires that have many loops each and are evenly distributed to form a three phase system. On some systems, the wires are connected to each other at one end and are connected to a rectifier assembly on the other end. On other systems, the wires are connected to each other end to end, and at each of the three connection points, there is also a connection to the rectifier. More on what a rectifier is later.
- The rotor contains the powerful magnet that passes close to the many wire loops that make up the stator. The magnets in the rotor are actually electro magnets, not a permanent magnets. This is done so that we can control how much voltage the alternator produces by regulating the amount of current that creates the magnetic field in the rotor. In this way, we can control the output of the alternator to suit our needs, and protect the circuits in the automobile from excessive voltage.
- Now we know that every magnet has a north and a South Pole and electro magnets are no exception. Our rotor has two interlocking sections of electro magnets that are arranged so that there are fingers of alternating north and south poles. that are evenly distributed on the outside of the rotor.
- When we spin the rotor inside the stator and apply current to the rotor through a pair of brushes that make constant contact with two slip rings on the rotor shaft. This causes the rotor to become magnetized. The alternating north and south pole magnets spin past the three sets of wire loops in the stator and produce a constantly reversing voltage in the three wires. In other words, we are producing alternating current in the stator.
- Now, we have to convert this alternating current to direct current current. This is done by using a series of 6 diodes that are mounted in a rectifier assembly. A diode allows current to flow only in one direction. If

voltage tries to flow in the other direction, it is blocked. The six diodes are arranged so that all the voltage coming from the alternator is aligned in one direction thereby converting AC current into DC current.

- There are 2 diodes for each of the three sets of windings in the stator. The two diodes are facing in opposite directions, one with its north pole facing the windings and the other with its south pole facing the windings. This arrangement causes the AC current coming out of the windings to be converted to DC current before it leaves the alternator through the B terminal. Connected to the B terminal of the alternator is a fairly heavy wire that runs straight to the battery.
- Current to generate the magnetic field in the rotor comes from the ignition switch and passes through the voltage regulator. Since the rotor is spinning, we need a way to connect this current from the regulator to the spinning rotor. This is accomplished by wires connected to two spring loaded brushes that rub against two slip rings on the rotor's shaft. The voltage regulator monitors the voltage coming out of the alternator and, when it reaches a threshold of about 14.5 volts, the regulator reduces the current in the rotor to weaken the magnetic field. When the voltage drops below this threshold, the current to the rotor is increased.
- There is another circuit in the alternator to control the charging system warning lamp that is on the dash. Part of that circuit is another set of diodes mounted inside the alternator called the diode trio. The diode trio takes current coming from the three stator windings and passes a small amount through three diodes so that only the positive voltage comes through. After the diodes, the wires are joined into one wire and sent out of the alternator at the L connection. It then goes to one side of the dash warning lamp that is used to tell you when there is a problem with the charging system. The other side of the lamp is connected to the run side of the ignition switch. If both sides of the warning lamp have equal positive voltage, the lamp will not light. Remove voltage from one side and the lamp comes on to let you know there is a problem.
- This system is not very efficient. There are many types of malfunctions of the charging system that it cannot detect, so just because the lamp is not lit does not mean everything is ok. A volt meter is probably the best method of determining whether the charging system is working properly.

The Voltage Regulator

- The voltage regulator can be mounted inside or outside of the alternator housing. If the regulator is mounted outside (common on some Ford products) there will be a wiring harness connecting it to the alternator.
- The voltage regulator controls the field current applied to the spinning rotor inside the alternator. When there is no current applied to the field, there is no voltage produced from the alternator. When voltage drops below 13.5 volts, the regulator will apply current to the field and the alternator will start charging. When the voltage exceeds 14.5 volts, the regulator will stop supplying voltage to the field and the alternator will stop charging. This is how voltage output from the alternator is regulated.
- Amperage or current is regulated by the state of charge of the battery. When the battery is weak, the electromotive force (voltage) is not strong enough to hold back the current from the alternator trying to recharge the battery. As the battery reaches a state of full charge, the electromotive force becomes strong enough to oppose the current flow from the alternator, the amperage output from the alternator will drop to close to zero, while the voltage will remain at 13.5 to 14.5.
- When more electrical power is used, the electromotive force will reduce and alternator amperage will increase. It is extremely important that when alternator efficiency is checked, both voltage and amperage outputs are checked. Each alternator has a rated amperage output depending on the electrical requirements of the vehicle.

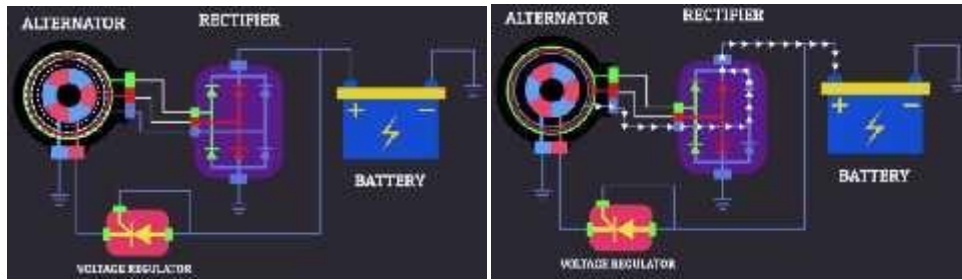

Stator coil working

continuously battery charging

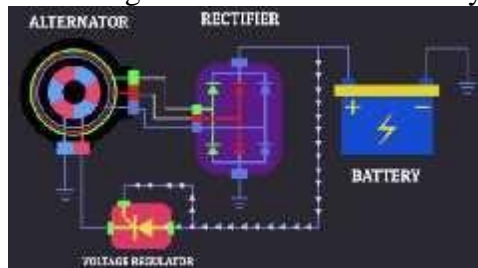

Current goes through all the electrical system

Typical Alternator Circuit

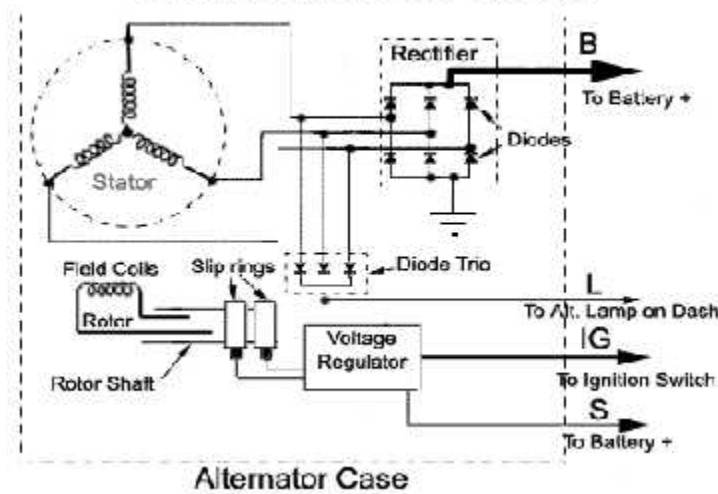

Alternator Case

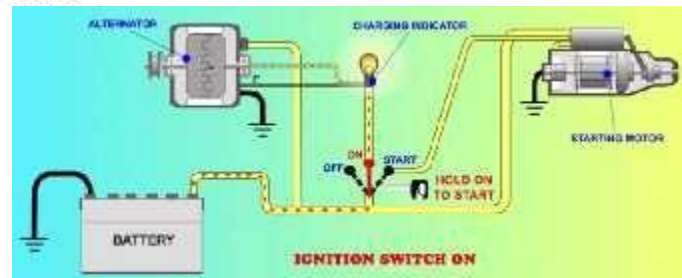
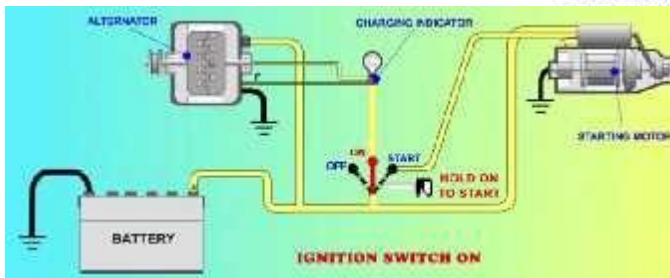

Battery

- The batteries are a reservoir of chemical electrical power. Their primary purpose is to crank the engine. They also supply power to vehicle accessories when the electrical load is too great for the alternator alone. The battery also acts as a voltage stabilizer. The battery must always remain attached to the electrical system while the engine is running.

Charging Indicator

- The charging indicator is usually an ON /OFF warning lamp. When the system is running, the light should be off. The lamp lights when the charging system is not providing sufficient charge.

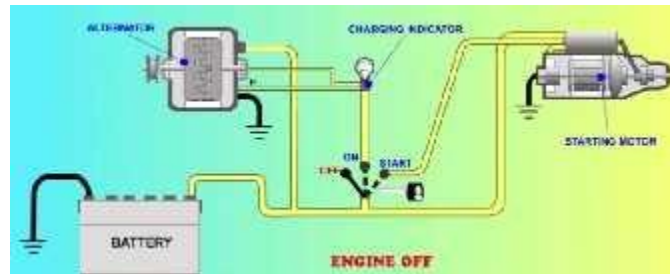
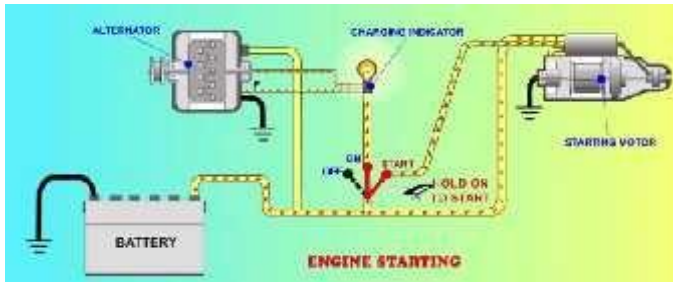

Both Starting system and charging system

STARTING SYSTEM

- The "starting system", the heart of the electrical system in your car, begins with the **Battery**. The key is inserted into the **Ignition Switch** and then turned to the start position. A small amount of current then passes through the **Neutral Safety Switch** to a **Starter Relay** or **Starter Selenoid** which allows high current to flow through the **Battery Cables** to the **Starter Motor**.
- The starter motor then cranks the engine so that the piston, moving downward, can create a suction that will draw a **Fuel/Air** mixture into the cylinder, where a spark created by the **Ignition System** will ignite this mixture. If the **Compression** in the engine is high enough and all this happens at the right **Time**, the engine will start.

Battery

- The automotive battery, also known as a lead-acid storage battery, is an electrochemical device that produces voltage and delivers current. In an automotive battery we can reverse the electrochemical action, thereby recharging the battery, which will then give us many years of service. The purpose of the battery is to supply current to the starter motor, provide current to the ignition system while cranking, to supply additional current when the demand is higher than the alternator can supply and to act as an electrical reservoir.
- The automotive battery requires special handling. The electrolyte (water) inside the battery is a mixture of sulfuric acid and water. Sulfuric acid is very corrosive; if it gets on your skin it should be flushed with water immediately; if it gets in your eyes it should be flushed with a mild solution of baking soda and water immediately and you should see a doctor as soon as possible. Sulfuric acid will eat through clothing, so it is advisable to wear old clothing when handling batteries. It is also advisable to wear goggles and gloves while servicing the battery. When charging, the battery will emit hydrogen gas; it is therefore extremely important to keep flames and sparks away from the battery.

- Because batteries emit hydrogen gas while charging, the battery case cannot be completely sealed. Years ago there was a vent cap for each cell and we had to replenish the cells when the electrolyte evaporated. Today's batteries (maintenance free) have small vents on the side of the battery; the gases emitted have to go through baffles to escape. During this process the liquid condenses and drops back to the bottom of the battery. There's need to replenish or add water to the battery.
- Today's batteries are rated in cold cranking amps. This represents the current that the battery can produce for 30 seconds at 0 degrees before the battery voltage drops below 7.2 volts. An average battery today will have a CCA (Cold Cranking Amps) of 500. With the many different makes and models of cars available today, batteries will come in many different sizes, but all sizes come in many CCAs. Make sure you get a battery strong enough to operate properly in your car. The length of the warranty is not indicative of the strength of the battery.
- Battery cables are large diameter; multi stranded wire which carry the high current (250+ amps) necessary to operate the starter motor. Some battery cables will have a smaller wire, soldered to the terminal, which is used to either operate a smaller device or to provide an additional ground. When the smaller cable burns it indicates a high resistance in the heavy cable.
- Even maintenance free batteries need periodic inspection and cleaning to insure they stay in good working order. Inspect the battery to see that it is clean and that it is held securely in its carrier. Some corrosion naturally collects around the battery. Electrolyte condensation contains corrosive sulfuric acid, which eats away the metal of battery terminals, cable ends and battery hold down parts. To clean away the corrosion, use a mixture of baking soda and water, and wash all the metal parts around the battery, being careful not to allow any of the mixture to get into the battery (batteries with top cell caps and vents). Rinse with water. Remove the battery cables from the battery (negative cable first), wire brush the inside of the cable end and the battery post. Reinstall the cables (negative end last). Coat all exposed metal parts(paint or grease can be used) so that the sulfuric acid cannot get on the metal.

Ignition switch

The ignition switch allows the driver to distribute electrical current to where it is needed. There are generally 5 key switch positions that are used:

1. **Lock-** All circuits are open (no current supplied) and the steering wheel is in the lock position. In some cars, the transmission lever cannot be moved in this position. If the steering wheel is applying pressure to the locking mechanism, the key might be hard to turn. If you do experience this type of condition, try moving the steering wheel to remove the pressure as you turn the key.
2. **Off-** All circuits are open, but the steering wheel can be turned and the key cannot be extracted.
3. **Run-** All circuits, except the starter circuit, are closed (current is allowed to pass through). Current is supplied to all but the starter circuit.
4. **Start-** Power is supplied to the ignition circuit and the starter motor only. That is why the radio stops playing in the start position. This position of the ignition switch is spring loaded so that the starter is not engaged while the engine is running. This position is used momentarily, just to activate the starter.
5. **Accessory-** Power is supplied to all but the ignition and starter circuit. This allows you to play the radio, work the power windows, etc. while the engine is not running.

Most ignition switches are mounted on the steering column. Some switches are actually two separate parts;

- The **lock** into which you insert the key. This component also contains the mechanism to lock the steering wheel and shifter.
- The **switch** which contains the actual electrical circuits. It is usually mounted on top of the steering column just behind the dash and is connected to the lock by a linkage or rod.

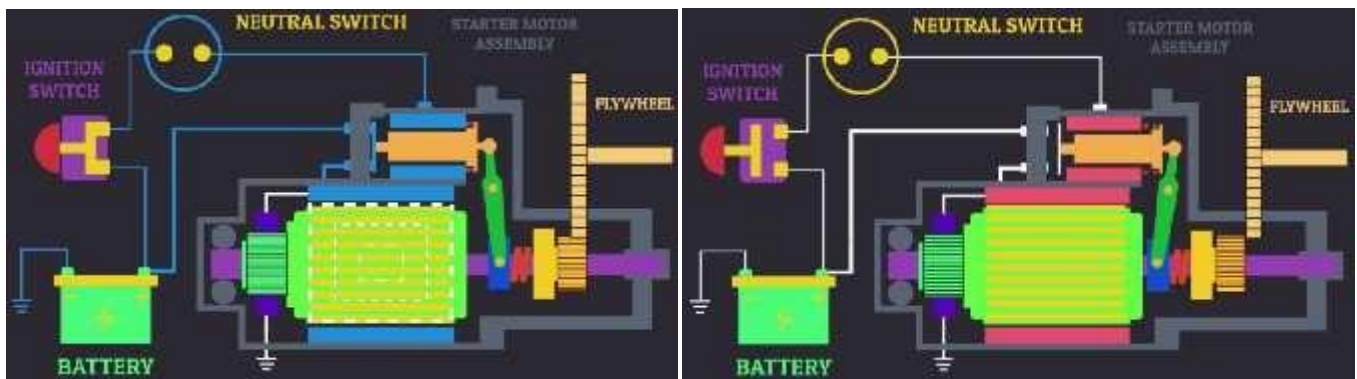
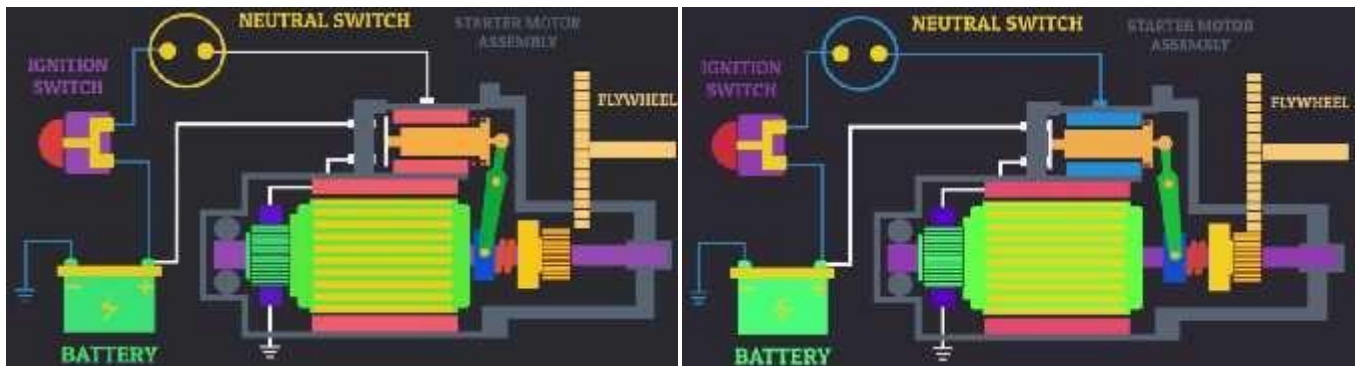
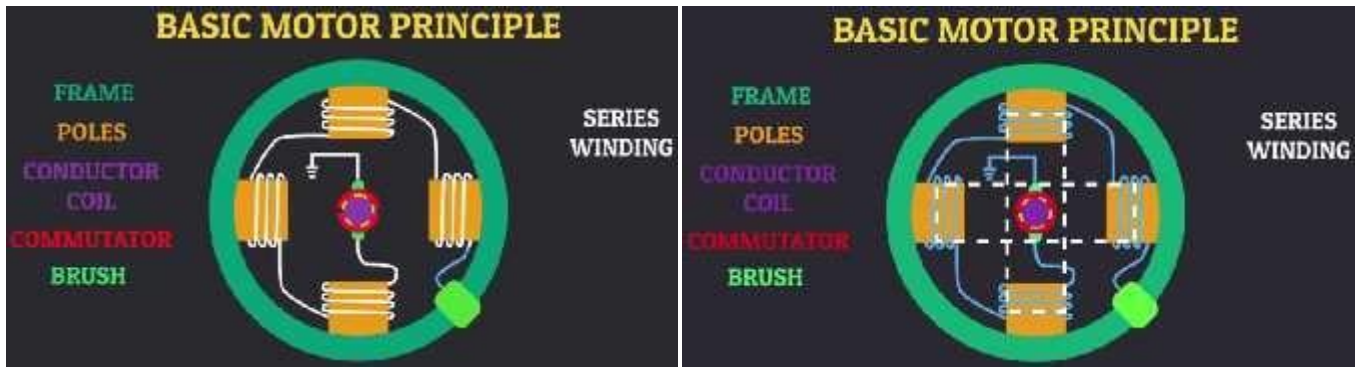

Neutral safety switch

- This switch opens (denies current to) the starter circuit when the transmission is in any gear but Neutral or Park on automatic transmissions. This switch is normally connected to the transmission linkage or directly on the transmission. Most cars utilize this same switch to apply current to the back up lights when the transmission is put in reverse. Standard transmission cars will connect this switch to the clutch pedal so that the starter will not engage unless the clutch pedal is depressed. If you find that you have to move the shifter away from park or neutral to get the car to start, it usually means that this switch needs adjustment. If your car has an automatic parking brake release, the neutral safety switch will control that function also.

Starter Relay

- A relay is a device that allows a small amount of electrical current to control a large amount of current. An automobile starter uses a large amount of current (250+ amps) to start an engine. If we were to allow that much current to go through the ignition switch, we would not only need a very large switch, but all the wires would have to be the size of battery cables (not very practical). A starter relay is installed in series between the battery and the starter. Some cars use a starter solenoid to accomplish the same purpose of allowing a

small amount of current from the ignition switch to control a high current flow from the battery to the starter. The starter solenoid in some cases also mechanically engages the starter gear with the engine.

Battery Cables

- Battery cables are large diameter, multistranded wire which carry the high current (250+ amps) necessary to operate the starter motor. Some have a smaller wire soldered to the terminal which is used to either operate a smaller device or to provide an additional ground. When the smaller cable burns, this indicates a high resistance in the heavy cable. Care must be taken to keep the battery cable ends (terminals) clean and tight. Battery cables can be replaced with ones that are slightly larger but never smaller.

Starter motor

- The starter motor is a powerful electric motor, with a small gear (pinion) attached to the end. When activated, the gear is meshed with a larger gear (ring), which is attached to the engine. The starter motor then spins the engine over so that the piston can draw in a fuel/ air mixture, which is then ignited to start the engine. When the engine starts to spin faster than the starter, a device called an overrunning clutch (bendix drive) automatically disengages the starter gear from the engine gear.

STANDARD BENDIX DRIVE

- **PINION DRIVE ASSEMBLY.-** The pinion drive assembly includes the pinion gear, the pinion drive mechanism, and solenoid. There are two ways that a starting motor can engage the pinion assembly- (1) with a moveable pole shoe that engages the pinion gear and (2) with a [solenoid](#) and shift fork that engages the pinion gear.
- The pinion gear is a small gear on the armature shaft that engages the ring gear on the flywheel. Most starter pinion [gears](#) are made as part of a pinion drive mechanism. The pinion drive mechanism slides over one end of the starter armature shaft.
- The pinion drive mechanisms found on starting motors that you will encounter are of three designs- Bendix drive, overrunning clutch, and Dyer drive.

Bendix drive

- The bendix drive relies on the principle of inertia to cause the pinion gear to mesh with the ring gear. When the starting motor is not operating, the pinion gear is out of mesh and entirely away from the ring gear. When the ignition switch is engaged, the total battery [voltage](#) is applied to the starting motor, and the armature immediately starts to rotate at high speed.

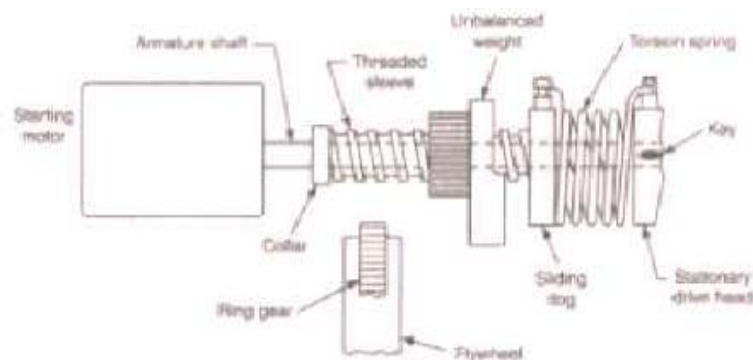

Standard Bendix drive

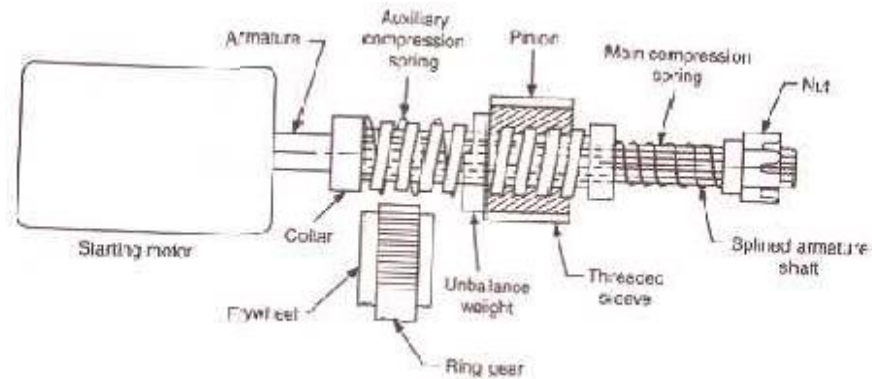

Bendix Drive with Compression Spring

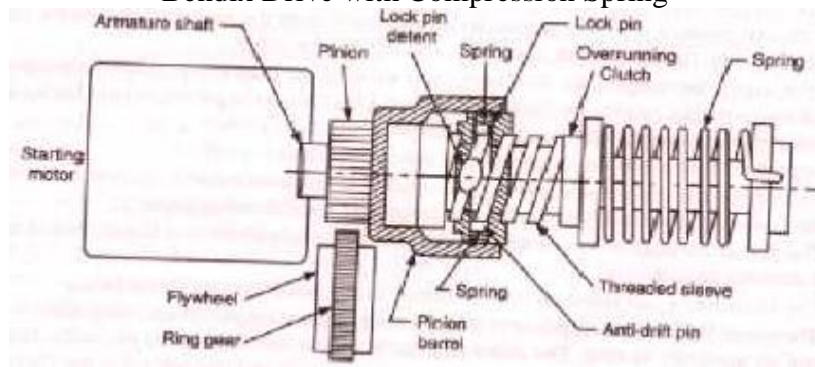

Folo-thru Starting Drive

- The pinion, being weighted on one side and having internal screw threads, does not rotate immediately with the shaft but because of inertia, runs forward on the revolving threaded sleeve until it engages with the ring gear.
- If the teeth of the pinion and ring gear do not engage, the drive spring allows the pinion to revolve and forces the pinion to mesh with the ring gear.
- When the pinion gear is engaged fully with the ring gear, the pinion is then driven by the starter through the compressed drive spring and cranks the engine. The drive spring acts as a cushion while the engine is being cranked against compression. It also breaks the severity of the shock on the teeth when the gears engage and when the engine kicks back due to ignition.
- When the engine starts and runs on its own power, the ring gear drives the pinion at a higher speed than does the starter. This action causes the pinion to turn in the opposite direction on the threaded sleeve and automatically disengages from the ring gear. This prevents the engine from driving the starter.

OVERRUNNING CLUTCH

- The overrunning clutch provides positive meshing and demeshing of the starter motor pinion gear and the ring gear. The starting motor armature shaft drives the shell and sleeve assembly of the clutch. The rotor assembly is connected to the pinion gear which meshes with the engine ring gear. Spring-loaded steel rollers are located in tapered notches between the shell and the rotor.
- The springs and plungers hold the rollers in position in the tapered notches. When the armature shaft turns, the rollers are jammed between the notched surfaces, forcing the inner and outer members of the assembly to rotate as a unit and crank the engine.

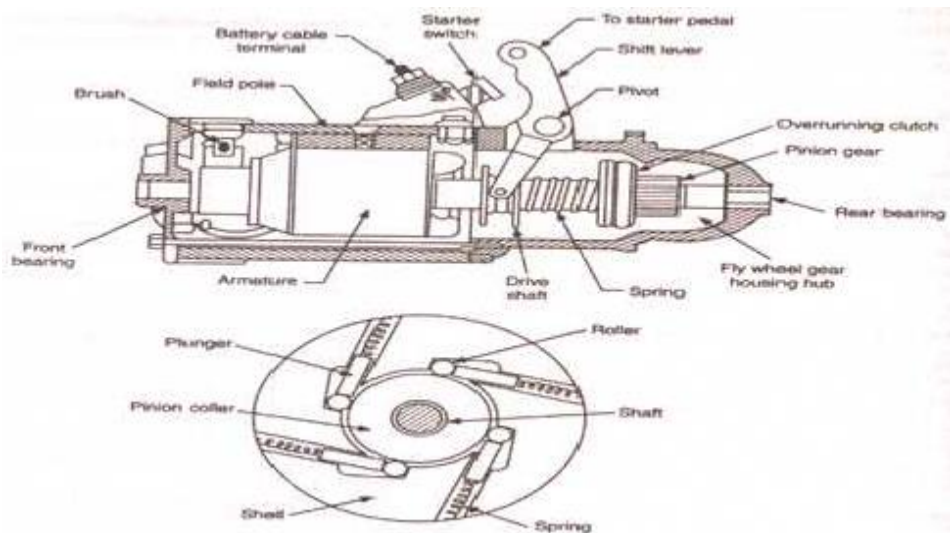

Typical overrunning clutch.

- After the engine is started, the ring gear rotates faster than the pinion gear, thus tending to work the rollers back against the plungers, and thereby causing an overrunning action. This action prevents excessive speed of the starting motor. When the starting motor is released, the collar and spring assembly pulls the pinion out of mesh with the ring gear.

DYER DRIVE

- The dyer drive provides complete and positive meshing of the drive pinion and ring gear before the starting motor is energized. It combines principles of both the Bendix and overrunning clutch drives and is commonly used on heavy-duty engines.
- A starter solenoid is used to make the electrical connection between the battery and the starting motor. The starter solenoid is an electromagnetic switch; it is similar to other relays but is capable of handling higher current levels. A starter solenoid, depending on the design of the starting motor, has the following functions:
 - Closes battery-to-starter circuit. Rushes the starter pinion gear into mesh with the ring gear.
 - Bypass resistance wire in the ignition circuit.
 - The starter solenoid may be located away from or on the starting motor. When mounted away from the starter, the solenoid only makes and breaks electrical connection. When mounted on the starter, it also slides the pinion gear into the flywheel.
- In operation, the solenoid is actuated when the ignition switch is turned or when the starter button is depressed. The action causes current to flow through the solenoid (causing a magnetic attraction of the plunger) to ground. The movement of the plunger causes the shift lever to engage the pinion with the ring gear. After the pinion is engaged, further travel of the plunger causes the contacts inside the solenoid to close and directly connects the battery to the starter.

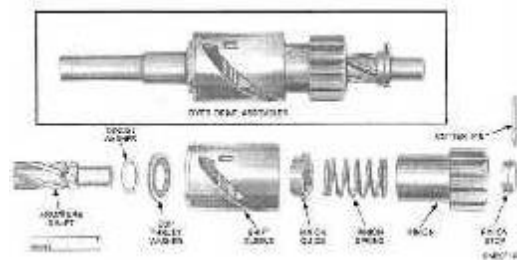

Dyer drive.

- The starter solenoid may be located away from or on the starting motor. When mounted away from the starter, the solenoid only makes and breaks electrical connection. When mounted on the starter, it also slides the pinion gear into the flywheel.
- In operation, the solenoid is actuated when the ignition switch is turned or when the starter button is depressed. The action causes current to flow through the solenoid (causing a magnetic attraction of the plunger) to ground. The movement of the plunger causes the shift lever to engage the pinion with the ring gear. After the pinion is engaged, further travel of the plunger causes the contacts inside the solenoid to close and directly connects the battery to the starter.
- If cranking continues after the control circuit is broken, it is most likely to be caused by either shorted solenoid windings or by binding of the plunger in the solenoid. Low [voltage](#) from the battery is often the cause of the starter making a clicking sound. When this occurs, check all starting circuit connections for cleanliness and tightness.

MECHANISM OF SOLENOID SWITCH

- Solenoid switches are used to switch high power circuits on and off using a much smaller electrical control signal to actuate the switching. This allows extensive logic and decision making circuitry to be performed on inexpensive microchips and small electronic parts, with the actual switching of the high power signals being limited to the very last step.
- The result is cooler running of less sophisticated equipment. It also enables the high power switching equipment to be limited to a remote location. Solenoid switches are typically used on automotive engine starting systems.

Solenoid Switch Operation

- Solenoids are wound wire magnetic coils with an open core to receive a sliding cylindrical plunger. When the coil is energized with an electrical current, a magnetic field is created in the hollow opening which pulls the plunger into it or pushes it out, based on the orientation of the solenoid and the poles of the plunger.
- The plunger is mechanically connected to a set of switch contacts, which perform the high power switching. There are a minimum of four connector terminals on a solenoid switch.
- The coil requires two and is most often isolated from all the other terminals, which keeps the coil wires completely independent of the current being switched. The switched current terminals are usually substantially heavier than the coil terminals.

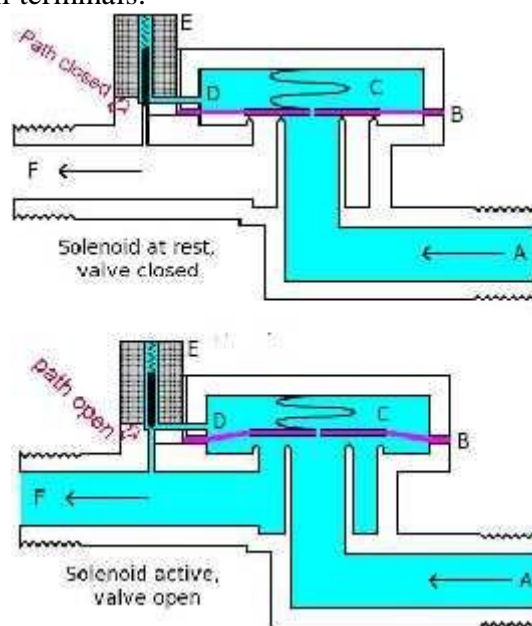

Solenoid switch working principle.

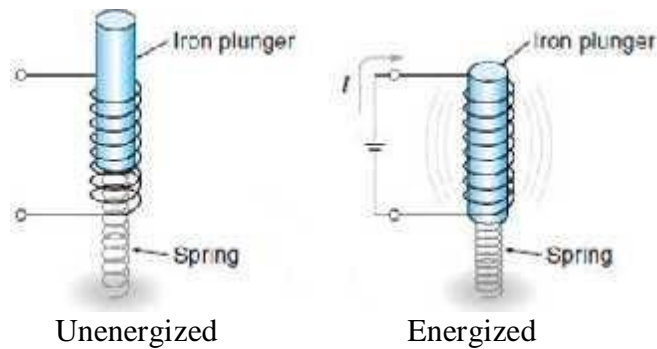

Switch Types

- Most solenoid switches have only one switched pole due to the amount of current being passed through them. Some are only momentarily operated, such as is the case with starter solenoids on automobiles.
- Once the automotive engine is started, the starter motor and solenoid are completely isolated from the operation of the rest of the electrical system.
- Some non-inertial automotive starting systems also use the moving plunger to slide the starter pinion along the starter shaft to engage the flywheel, in addition to actually powering the starter motor.

Solenoid Switches versus Relays

- Whereas solenoids impart substantial motion to their plungers, either for switches or valves, the coils of electrical relays are wound around a ferrous magnetic post which becomes magnetized and attracts a steel plate across a small gap to close a set of electrical contacts.
- These contacts may switch more than one pole and are commonly used to switch AC line currents at 120, 240 or 480 volts, although relays are available for both AC and DC switching and any voltage range. Solenoid switches perform both electrical switching and coordinated mechanical motion.

Solenoid Switch Applications

- Besides wide scale engine starting applications, solenoid switches are used to switch on many other types of motors while mechanically engaging or disengaging their shafts. This allows latching and opening mechanisms for windows, doors and hatches to derive two functions from the same piece of coordinated equipment.

Engage Then Turn On

- Since solenoid switches typically place the switch contacts at the very end of the plunger stroke, they act as self contained logic interlocks, not allowing a motor to start or a valve to open until the plunger has moved its entire distance first.

Limitation of Solenoid valve

- The main limitation of the solenoid is its short stroke, which is usually under an inch.
- Still, there are many applications for short-stroke linear motion; examples are activating electric car-door locks, opening and closing valves, and triggering mechanical latches.
- Most applications use the solenoid as a on or off device—that is, the coil is either completely energized or switched off. However, variable-position control is possible by varying the input voltage.

LIGHTING SYSTEM

- The lighting system of a motor vehicle consists of lighting and signalling devices mounted or integrated to the front, rear, sides, and in some cases the top of a motor vehicle. This lights the roadway for the driver and increases the visibility of the vehicle, allowing other drivers and pedestrians to see a vehicle's presence, position, size, direction of travel, and the driver's intentions regarding direction and speed of travel. Emergency vehicles usually carry distinctive lighting equipment to warn drivers and indicate priority of movement in traffic.

- Statutory regulations specify the number, position and specification of many of the external lights fitted to a vehicle. In addition to the obligatory lights, manufacturers and owners of the vehicle often install other supplementary lights to meet other requirements. Various lamps are grouped in separate circuits, which include the following
 - ❖ Side and rear lamps including lamps for the number plate, glove compartment and instrument panel illumination.
 - ❖ Main driving lamps (headlamps) incorporating a dipped facility to prevent approaching drivers being dazzled.
 - ❖ Rear fog lamp(s) to guard the rear of the vehicle in conditions of poor visibility.
 - ❖ Auxiliary driving lamps including spot lamps for distance illumination and fog lamps to reduce the reflected glare from fog.
 - ❖ Reversing lamps to illuminate the road when the vehicle is moving backwards and warn other drivers of the movement.
 - ❖ Brake lights to warn a following driver that the vehicle is slowing down.
 - ❖ Interior light and courtesy lights on doors.
 - ❖ Instrument panel lights to signal the correct operation of a unit or the presence of a fault in a particular system.
 - ❖ Directional indicators and hazard warning lights.

Circuit Layout

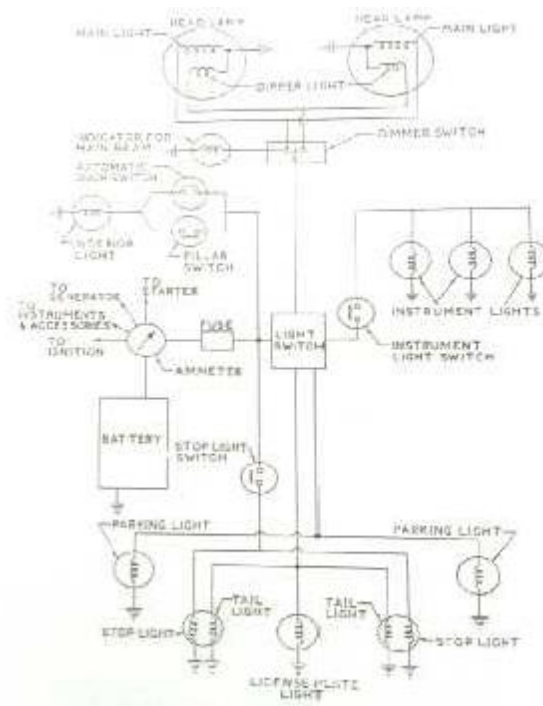

Lighting circuit

- To obtain maximum illumination the lamps are connected in parallel. With the arrangement an open circuit in any branch causes failure only in that one branch, the other lamps still function normally. The vehicle lighting systems normally use an earth return circuit, because this requires less cable length than an insulated return or two wire system.

- When the vehicle body is used as an earth, a good clean connection must be provided at suitable earthing points on the main body. This earthing lead is specifically essential if the lamp is fitted in a plastics body panel.
- Lighting circuit diagrams are presented in either a locational or compact theoretical form. In the former type each component is located relative to its position on the vehicle. This is useful in indicating the location of the various connectors and components, but the diagram becomes more difficult to trace out a particular circuit path.
- To avoid this problem, some manufactures make use of extra diagrams to indicate separate parts of the circuit. Figure illustrates a simple circuit drawn on above concepts.

HORN

- Horns are simple electromagnetic devices that produce loud, audible sounds to get the attention of nearby vehicle occupants or pedestrians. A typical horn is composed of a magnetic coil, an armature with a metal diaphragm, a pair of electrical contacts, and a switch.
- When the driver activates the switch, the closed electric contact allows a current to flow through the coil generating a magnetic force that attracts the armature, as well as the metal diaphragm. This action breaks the electric contact, cutting off the current and releasing the armature and diaphragm.
- When they move back to their initial positions, the electrical contact is re-made and the cycle repeats. The rapid repetition of this process generates an oscillation of the diaphragm and creates the horn's sound.
- In general; there are two types of horn shapes: plate and spiral. The plate type is smaller and lighter. It is also more easily installed on a car. The spiral type employs a spiral duct to obtain a richer sound. Most horns assemblies have two horns (low and high notes) and achieve sound levels of approximately 107-109 decibels.
- The frequency of the horn is usually related to the size of the vehicle. Bigger vehicles generally have lower frequency horns, while smaller vehicles have higher frequency horns. The sound for luxury cars is often "smooth" compared to economy cars with less refined tones. Many countries mandate a car's specific horn frequency.
- Horns installed on trucks are usually driven by compressed air instead of current. Air horns can generate very loud sounds, typically at levels of 117-118 decibels.

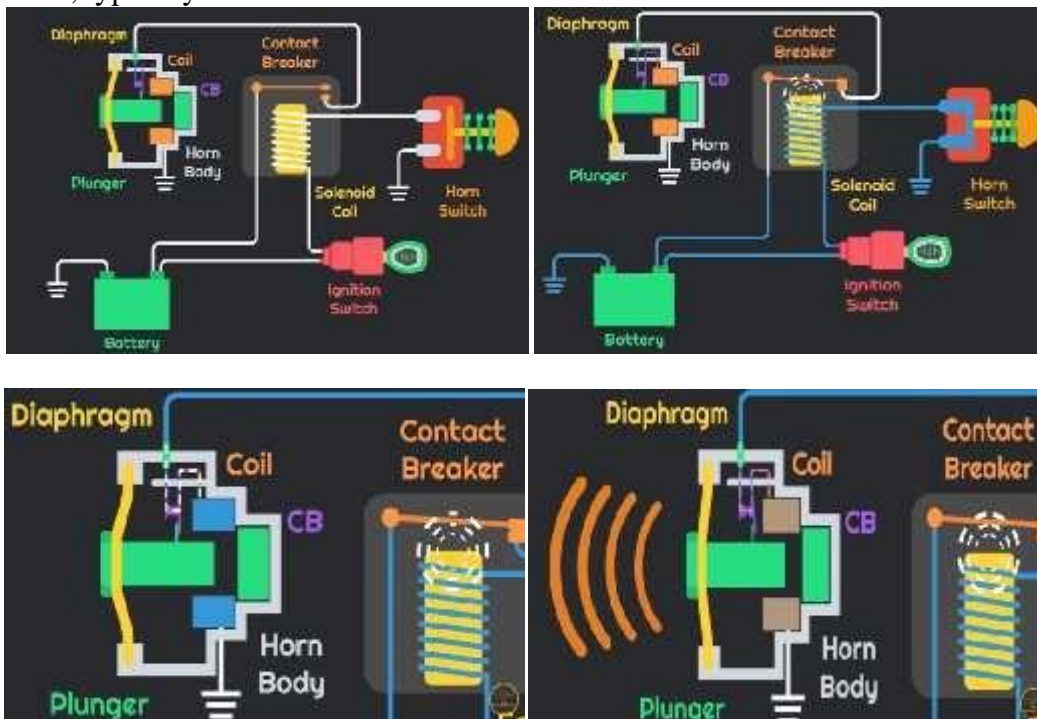

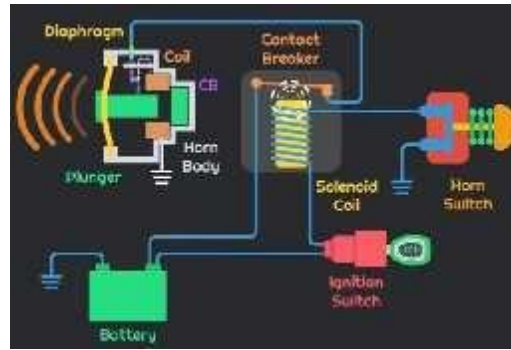

Horn working system

WIPER

- A windscreen wiper or windshield wiper (American English) is a device used to remove rain, snow, ice and debris from a vehicle's front window. Almost all motor vehicles, including cars, trucks, buses, train locomotives, and watercraft with a cabin and some aircraft are equipped with one or more such wipers, which are usually a legal requirement.
- A wiper generally consists of a metal arm; one end pivots, the other end has a long rubber blade attached to it. The arm is powered by a motor, often an electric motor, although pneumatic power is also used for some vehicles.
- The blade is swung back and forth over the glass, pushing water, other precipitation, or any other impediments to visibility, from its surface. On vehicles made after 1969, the speed is normally adjustable, with several continuous speeds, and often one or more intermittent settings.
- Most personal automobiles use two synchronized radial-type arms, while many commercial vehicles use one or more pantograph arms.
- On some vehicles, a windscreen/windshield washer system is also used to improve and expand the function of the wiper(s) to dry or icy conditions. This system sprays water, or an antifreeze window washer fluid, at the windscreen using several well-positioned nozzles. This system helps remove dirt or dust from the windscreen when it is used in concert with the wiper blades. When antifreeze washer fluid is used, it can help the wipers remove snow or ice.
- For these types of winter conditions, some vehicles have additional heaters aimed at the windows, or embedded heating wire(s) in the glass; these defroster systems help to keep snow and ice from building up on the windscreen. Less frequently, miniature wipers are installed on headlights to ensure that they function optimally.

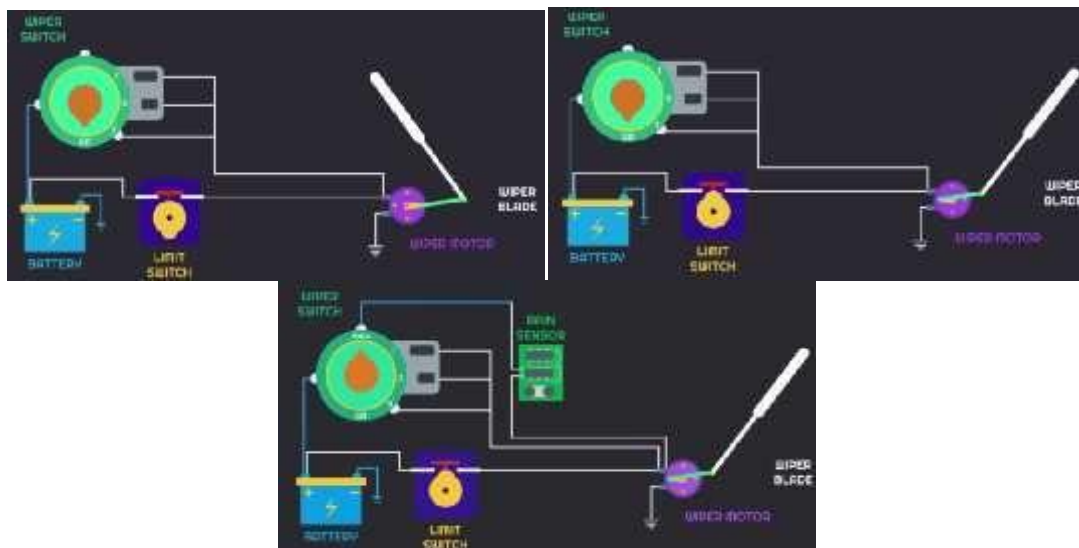

Wiper working system

How Windshield Wipers Work

- The windshield wiper is moved by a motor at the base of the window to clear the window of rain. There are multiple ways for the windshield wipers to be configured. Most cars have two wipers which move in sync with each other, but some models such as Fiat, Citroen, Subaru, and Mercedes have a single wiper that covers a wider swatch of window.
- There are also some models of vehicle that come with a wiper on the back window, such as SUVs, hatchbacks, and minivans. Also important to note are the few older vehicle models that have wipers on their headlights like Saab and Chevrolet.

The Parts of a Windshield Wiper

- Like most systems in a vehicle, the windshield wiper is made up of many parts. The main parts of the windshield wiper are:
 - ❖ **Wiper Blades** - The wiper blades are what removes the moisture from the windshield
 - ❖ **Wiper Arm** - The wiper arm connects the wiper blade to the wiper transmission, to allow for unhindered movement over a large patch of the windshield
 - ❖ **Wiper Transmission** - The windshield wiper transmission controls the movement of the wiper arm
 - ❖ **Wiper Motor** - The windshield wiper motor provides power to the wiper transmission and fluid pump
 - ❖ **Windshield wiper fluid pump, tanks and tubes** - The windshield wiper fluid pump, tanks, and tubes are the system responsible for spraying out windshield wiper fluid, allowing the driver to clean a dirty windshield
 - ❖ **Windshield Wiper Interior Controls** - The windshield wiper internal controls are located either on a control arm protruding from the steering wheel, on the steering wheel, or on the main dashboard panel, to the left of the main dash display

FUEL GAUGE

- A fuel gauge is a measuring instrument that determines and reports the amount of fuel that is left in a vehicle's tank or tanks. Each gauge consists of two separate components: an indicator and a sensing or sending unit.
- The indicator is the part of the gauge that is located on the dash, typically in the instrument cluster, while the sensing unit is located in the fuel tank. There are a few different types of gas gauges, each of which works a little differently, but in general terms the sensing unit measures the fuel level, and the indicator reports that level.

Fuel Gauge Components

Every fuel gauge consists of two basic component parts:

- ❖ an indicator
- ❖ a sensor or sending unit

Fuel gauges can also include:

- ❖ a float
- ❖ a potentiometer

Fuel Gauge Operation

- The most common type of fuel gauge uses a sending unit that is installed in the fuel tank. The sending unit has a float that is mounted on an arm that allows it to move up and down with the level of fuel that is present in the tank. The arm, in turn, is attached to the potentiometer. As the arm moves up (with a full tank) and down (as the tank empties out), the resistance of the potentiometer changes.

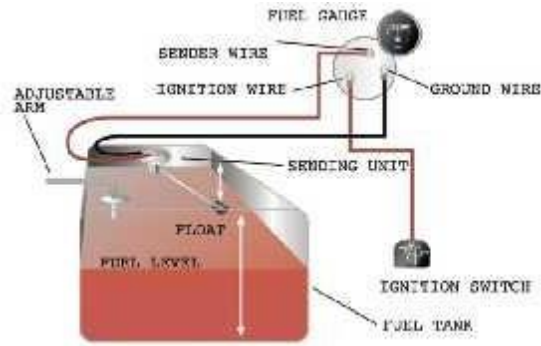

- When the ignition is turned on, an electrical current passes through the sending unit. Since the resistance of the potentiometer is tied directly to the level of the float, and current flow depends on the overall resistance of a circuit, the level of current flowing through the circuit is also tied directly to the level of gasoline in the tank.
- In this type of system, the gas level indicator measures the amount of current that is flowing through the sending unit at any given time. In most cases, a high level of current corresponds to a full tank, while a low level of current corresponds to an empty tank. This is so that if the sending unit malfunctions, the indicator will always read as empty.

Fuel Gauge Failure

- When a fuel gauge fails, it is typically the sending unit that goes bad. The gauge, wiring, and other components can also result in a malfunctioning fuel gauge, but sending units tend to fail more often. Since sending units are located inside fuel tanks, it can be time consuming to test or replace them. Unless a vehicle has an access port, the fuel tank typically must be removed.
- If a fuel gauge always reads empty, whether the tank is empty or full, then the problem is usually related to the sending unit. Either the potentiometer is bad, the float is stuck down, the internal wiring is bad, or there is an issue elsewhere in the circuit. Depending on how the specific fuel gauge system works in a vehicle, it may be necessary to remove the sending unit and check its resistance while manually operating the float arm.
- When a fuel gauge always reads full, the problem may be in the sending unit, the dash indicator, or the wiring. A float that is stuck in the up position will cause a fuel gauge to always read full, as will certain wiring and indicator issues.

OIL PRESSURE GAUGE

Functional Principle

- Standard oil pressure sensors work by displaying a warning signal when the oil pressure falls outside of the set range. Two important components to the oil pressure sensor include the spring-loaded switch and a diaphragm. The spring-loaded switch is connected to the diaphragm that is exposed to the oil pressure.
- The pressure switch is mounted onto the side of an engine block and wired to an oil gallery. As the force of the oil pressure starts to build on the diaphragm, this force overcomes the switch spring pressure, which then pulls apart the electrical contacts to turn on the warning light. If the oil pressure falls below the set limit, the diaphragm releases pressure off the springs to close the switch contacts that would normally result in the display of a warning sign to the driver.
- The low oil pressure indicator light is displayed on the dashboard of a vehicle. Any driver will know that when this light flashes continuously, it is indicating a momentary drop in the oil pressure. However, if this light remains switched on, the driver is alerted to a complete loss of oil pressure.
- So, when the engine to a vehicle is switched on, an electrical current travels from a fuse and straight to the oil pressure switch, making sure that the indicator light is 'off'. When oil pressure starts to rise above 4.3 psi (per square inch), the diaphragm moves apart the contacts, thus switching on the oil pressure light.

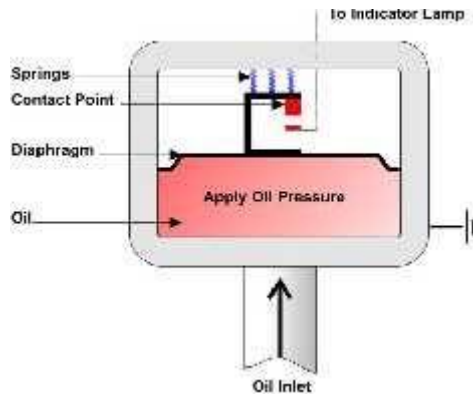

Working mechanism to an oil pressure sensor system.

Pressure Gauge Sensor

- A low oil pressure warning light is one method used to alert the driver to fluctuations in the oil pressure levels. An alternative system for this purpose is known as a mechanical type pressure gauge component. There is a Bourdon tube inside a pressure gauge that tends to straighten out upon receiving pressure via a copper tubular component.
- The Bourdon tube is attached to a needle on the gauge, which moves as the tube begins to take a different shape. Movement of the needle across a scale on the gauge is used as a reference point to indicate changes in oil pressure inside the engine to a vehicle.

ENGINE TEMPERATURE INDICATOR

Engine Temperature Sensor

The Engine Temperature Sensor accurately measures the engine coolant temperature. Thereby, it gives an indication of the temperature of the engine.

Engine Temperature Sensor working

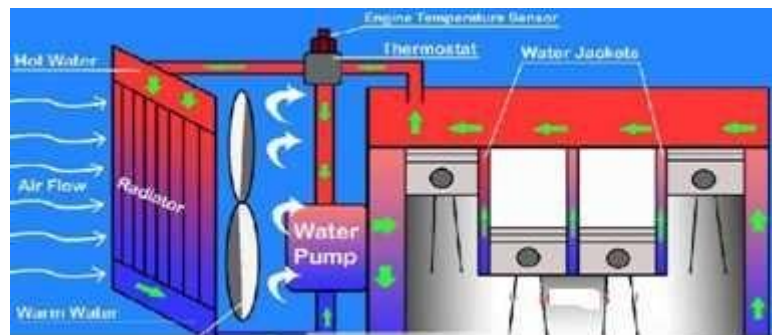
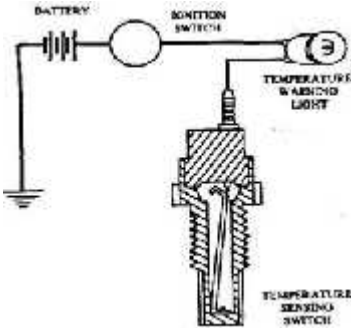

Engine temperature indicator

- The engine temperature sensor is a type of sensor that changes its resistance with temperature. Many critical engine functions such as selection of air-fuel ratio, fuel injection timing, ignition timing etc. depend on the engine's temperature. This is because a cold engine requires a rich air-fuel mixture; whereas the engine running at optimum operating temperature requires a lean mixture.
- The engine temperature sensor informs the engine's ECU about the current & ongoing variations in the engine temperature. ECU, in turn, adjusts and regulates the fuel quantity & ignition timing. The data from the engine temperature sensor provides readings for engine temperature gauge on the dashboard. Based on this data, the ECU also controls the additional functions such as switching on / off the engine cooling fan.

Coolant Temperature sensor location

- Engine Coolant Temperature sensor is primarily located in the coolant passage of the liquid cooled engine; typically near the thermostat valve.

- The engine temperature sensor connects either to the temperature gauge or to the temperature indicator in the dashboard. In modern cars, you will notice that there is no separate engine temperature gauge. Instead, there is a tiny 'light' symbolizing the engine temperature; which is integrated with rpm-meter.
- Upon turning the ignition 'ON', the letter 'C' also lights along with the temperature symbol; indicating that the engine is cold. It should automatically disappear; once the engine warms up to its optimum temperature (usually within 2/3 Kilometers of the drive).

The common causes of failure

- In most cases, the engine temperature sensor fails due to corrosion. This is because of its exposure to engine coolant. It may also fail if the coolant leaks through its wiring connector.

What to do if the engine temperature sensor fails?

- If you see that the engine temperature symbol 'C' is lit continuously and does not disappear after some time; it indicates that there is some problem in the engine's cooling system. Also, if the engine temperature goes above the prescribed levels (usually above 100° C), another symbol – a High-Temperature indicator light 'H' lights up in red color; indicating that the engine is over-heating.
- Furthermore, it is not safe to drive a car with the indicator light 'H' on. As it may cause further damage and/or seize the engine. Stop the car and look for any coolant (usually green colored) leakage. If there is a noticeable leakage, do not drive the car in that condition. Instead, tow it to the nearest service station for repair.

ENGINE MANAGEMENT SYSTEM

ENGINE MANAGEMENT SYSTEM

- Engine management system is, now-a-days, used in many of the modern cars such as Benz, Mitsuibisi, and Toyota etc. This system uses much electronic control system involving micro controllers. The generalized block diagram of this system is shown in fig.
- The objective of the system being to ensure that the engine is operated at its optimum settings.
- The system consists of many sensors for observing vehicle speed, engine temperature, oil and fuel pressure, airflow etc. These sensors are supplying input signals to the micro controller after suitable signal conditioning and providing output signals via drivers to actuate corresponding actuators.
- A single cylinder engine consists of some of these elements in relation to an engine is shown in fig. The engine sensor is an inductive type s It consists of a coil and sensor wheel. The inductance of the coil changes as the teeth of the sensor wheel pass it and so results in an oscillating voltage.
- The engine temperature sensor is generally thermocouple which is made of bimetallic strip or a thermistor. The resistance of the thermistor changes with change in engine temperature this result in voltage variation. Hot wire anemometer is used as a sensor for measuring mass airflow rate. The basic principle is that the heated wire will be cooled as air passes over it. The amount of cooling is depending on the mass rate of flow.
- The oil and pressure sensors are diaphragm type sensors. According to the pressure variation, the diaphragm may contract or expand and activates strain gauge which produces voltage variation in the circuit.
- The oxygen sensor is usually a close end tube which is made of Zirconium oxide with porous platinum electrode on the inner and outer Surfaces. The sensor becomes permeable to oxygen ions at about 300°C. This results in generation of voltage between the electrodes. The various drivers such as fuel injector drivers, ignition coil drivers. Solenoid drivers are used to actuate actuation according to the signal by various sensors.
- Analog signals given by sensors are converted into digital signal by using analog to digital converters (ADC) and sent it to micro controllers. The various output digital signals are converted into analog signals by DAC (i.e., Digital to Analog Converter) and shown in various recorders or meters.

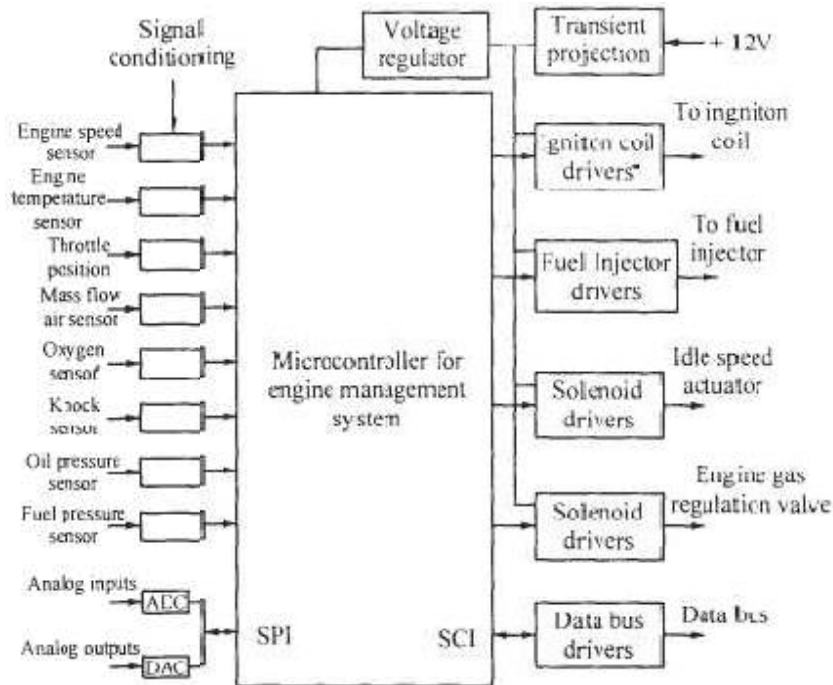
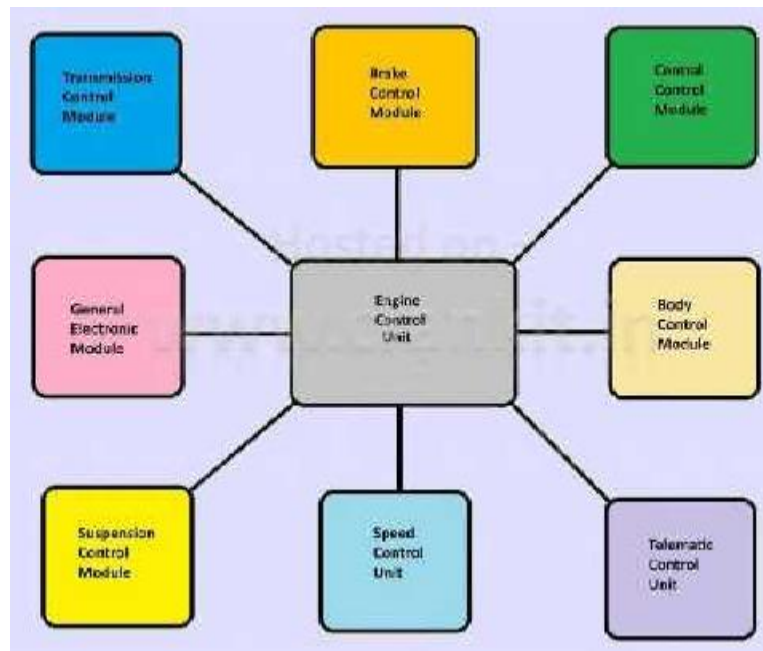

Block diagram of engine management system

- EMS stands for Engine Management System which consists of a wide range of electronic and electrical components such as sensors, relays, actuators and an Engine Control Unit. Furthermore, they work together to provide the Engine Management System with vital data parameters that are essential for governing various engine functions effectively. The Engine Management system is incorporated in the modern day engine technologies, such as MPFi & GDi systems in Petrol engines and CRDi system in diesel engines for improved performance.
- ECU stands for Engine Control Unit and ECM for Engine Control Module, both are the same. ECU/ECM is also a generic term for any Electronic Control Unit/Module respectively.

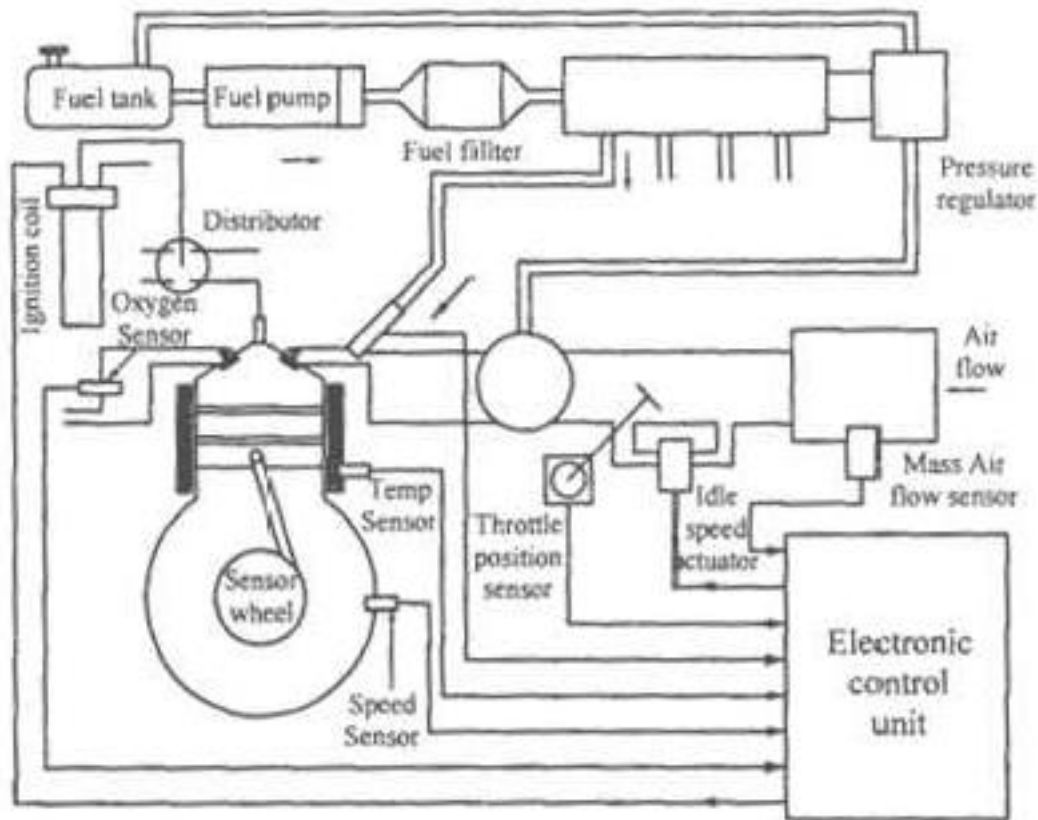

Engine management system with sensors and actuators

Engine Control Unit

- The Engine Control Unit is a central part of the Engine Management System which is virtually the 'Brain' of an engine. It plays an important role in collecting, analyzing, processing and executing the data it receives from various sub-systems. Furthermore, an ECU comprises a computer which uses a microchip to process the inputs from various engine sensors in real-time.
- The Electronic Control Unit contains hardware and software. The printed circuit board (PCB) of the ECU consists of a micro-controller chip or the CPU (Central Processing Unit). The software is stored on the micro-controller or chips on the PCB. It is possible to re-program the ECU by updating the software or by replacing chips. All the engine sensors send data inputs by the way of electrical signals to the ECU. The ECU, in turn, controls various actuators, ignition timing, variable valve timing etc.

Working of ECU

- Based on this data input, the ECU precisely calculates and delivers the ideal air-fuel mixture. It also regulates the idle speed of the engine and limits the top speed of a vehicle. This system is also widely referred to as an '**Electronic Engine Management System**' or the EMS. Furthermore, it is possible to customize the modern day ECUs to suit different vehicular applications and varying customer demands. In addition, some cars have an individual 'Control Module' for all major systems. A modern car has following individual Control Modules which control the respective systems.

SL.	Name of the Sensor	Purpose
01	Air–fuel Ratio Meter	Monitors the correct air-fuel ratio for the engine
02	Engine Speed Sensor	Monitors engine speed
03	Throttle Position Sensor	Monitors the position of the throttle in an engine
04	Crank Position Sensor	Monitors piston’s TDC position in the engine
05	Cam Position Sensor	Monitors position of valves in the engine
06	Knock Sensor	Detects engine knocking because of timing advance
07	Engine Coolant Temperature Sensor	Measures the engine temperature
08	Manifold Absolute Pressure or MAP Sensor	Used to regulate fuel metering
9	Mass Air Flow or MAF Sensor	Notifies the mass of air entering the engine to ECU
10	Oxygen/O ₂ /Lambda Sensor	Monitors the amount of oxygen in the exhaust
11	Fuel Pressure Sensor	Measures pressure in the fuel system
12	Vehicle Speed Sensor (VSS)	Measures the speed of a vehicle